

DNA1445-1475ZW

IR MP Bullet Cameras



Installation and Operations Manual

Model Number: DNA1445ZW, DNA1475ZW

Description: 2MP and 4MP IR Bullet Cameras
with Intelligent Analytics
and Motorized Vari-Focal Lens

Welcome

Thank you for purchasing our Network camera!

This user's manual is designed to be a reference tool for your system.

Please read the following safeguard and warnings carefully before you use this series product!

Please keep this user's manual well for future reference!

Important Safeguards and Warnings

1 . Electrical safety

- All installation and operation here should conform to your local electrical safety codes.
- Please check if the power supply is correct before operating the device.
- The power shall conform to the requirement in the SELV (Safety Extra Low Voltage) and the Limited power source is rated DC 12V or AC 24V in the IEC60950-1. (Power supply requirement is subject to the device label).
- Please install easy-to-use device for power off before installing wiring, which is for emergent power off when necessary.
- Please prevent the line cord from being trampled or pressed, especially the plug, power socket and the junction from the device.
- **Note: Do not connect these two power supplying sources to the device at the same time; it may result in device damage!**
- We assume no liability or responsibility for all the fires or electrical shock caused by improper handling or installation.
- We are not liable for any problems caused by unauthorized modification or attempted repair.

2 . Environment

- Please don't aim the device at strong light (such as lighting, sunlight and so on) to focus; otherwise it may cause overexposure (It is not the device malfunction), which will affect the longevity of CCD or CMOS.
- Please transport, use and store the device within the range of allowed humidity and temperature.
- Please don't keep the device in a place which is wet, dusty, extremely hot, and extremely cold and with strong electromagnetic radiation or unstable lighting.
- Please do not allow water and other liquid falling into the camera in case that the internal components are damaged.
- Please do not allow rain or damp to the indoor device in case fire or lightning may occur.
- Please keep the sound ventilation in case of heat accumulation.
- Please pack the device with standard factory packaging or material with same quality when transporting the device.
- Heavy stress, violent vibration or water splash are not allowed during transportation, storage and installation.

3. Operation and Daily Maintenance

- Please do not touch the heat dissipation component of the device directly in order to avoid scald.
- Please do not dismantle the device; there is no component which can be fixed by users themselves in the machine. It may cause water leakage or bad image for the device due to unprofessional dismantling. Please contact after-sale service to replace desiccant if it becomes green.
- It is recommended to use the device with thunder proof device in order to improve thunder proof effect.
- The grounding holes of the product are recommended to be grounded to further enhance the reliability of the camera.
- Do not touch the CCD (CMOS) optic component directly. User may use the blower to clean the dust or dirt on the lens surface. Please use a dry cloth wetted by alcohol to wipe away the dust gently if it is necessary to clean.
- Always use the dry soft cloth to clean the device. If there is too much dust, please use the water to dilute the mild detergent first and then use it to clean the device. Finally use the dry cloth to clean the device. Don't use volatile solvent like alcohol, benzene, thinner and etc or strong detergent with abrasiveness, otherwise it will damage the surface coating or reduce the working performance of the device.
- Dome cover is an optical device, please don't touch or wipe cover surface directly during installation and use, please refer to the following methods to deal with once dirt is found:
 - Stained with dirt
 - Use oil-free soft brush or hair dries to remove it gently.
 - Stained with grease or fingerprint
 - Use soft cloth to wipe the water drop or oil gently to make it dry, then use oil-free cotton cloth or paper soaked with alcohol or detergent to wipe from the lens center to outward. It is ok to change the cloth and wipe several times if it is not clean enough.

Warning

- Please modify the default password after login in order to avoid being stolen.
- Please use the standard accessories provided by manufacturer and make sure the device is installed and fixed by professional engineers.
- Please prevent the device surface from the radiation of laser beam when using laser beam device.
- Please do not provide two or more power supply modes for the device, otherwise it may cause damage to the device.

Statement

- Please refer to the actual product for more details; the manual is just for reference.
- The manual will be regularly upgraded according to the product update; the upgraded content will be added in the manual without prior announcement.
- Please contact the supplier or customer service if there is any problem occurred when using the device.

- Please contact the customer service for the latest procedure and supplementary documentation.
- There may be deviation between the actual value of some data and the value provided in the manual due to the reasons such as the changing environment. Please refer to the company's final explanation if there is any doubt or dispute.
- The company is not liable for any loss caused by the operation which is not followed by the manual.

FCC Information

1. FCC conditions :

This device complies with part 15 of the FCC Rules. Operation is subject to the following two conditions:

- This device may not cause harmful interference;
- This device must accept any interference received, including interference that may cause undesired operation.

2. FCC compliance :

This equipment has been tested and found to comply with the limits for a digital device, pursuant to part 15 of the FCC Rules. These limits are designed to provide reasonable protection against harmful interference. This equipment generates uses and can radiate radio frequency energy and, if not installed and used in accordance with the instruction manual, may cause harmful interference to radio communication. However, there is no guarantee that interference will not occur in a particular installation. If this equipment does cause harmful interference to radio or television reception, which can be determined by turning the equipment off and on, the user is encouraged to try to correct the interference by one or more of the following measures:

- Reorient or relocate the receiving antenna.
- Increase the separation between the equipment and receiver.
- Connect the equipment into an outlet on a circuit different from that to which the receiver is connected.
- Consult the dealer or an experienced radio/TV technician for help.

Note:

Please refer to the disk for more details, check and download corresponding user's manual and tool.

Before installation, please open the package and check all the components are included.

Contact your local retailer ASAP if something is broken in your package.

Accessory Name	Amount
Network Camera Unit	1
Quick Start Guide	1
Installation Accessories Bag	1
CD	1

Table of Contents

1	Device Structure	1
1.1	Device External Cable	1
1.2	Framework and Dimension	2
1.3	Alarm Setup.....	2
2	Device Installation	5
3	Network Configuration	9
3.1	Modify IP Address	9
3.2	Login WEB Interface	10

1 Device Structure

1.1 Device External Cable

Note:

The following figure is for reference only, which is used to know the function of cable port.

There are differences about cable structure between different models, please refer to the actual product for more details.

User may refer to the following figure for cable information. See Figure 1-1.

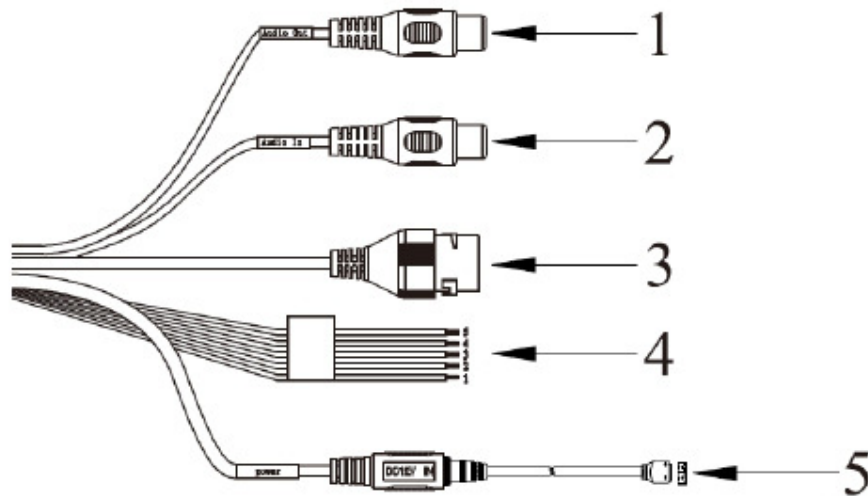

Figure 1-1

Please refer to the following sheet for detailed information.

No.	Port Name	Function	Connector	Note
1	AUDIO OUT	Audio output port	RCA	Output audio signal to speaker and etc.
2	AUDIO IN	Audio input port	RCA	Input audio signal, receive analog audio signal from pick up and etc.
3	LAN	Network port	Ethernet port	Connect to standard Ethernet cable. Note: Some series don't support PoE.
4	I/O	I/O port	-	Alarm signal input/output.
5	Power	Power input port	/	Power port. Input DC 12V or AC 24V power. Note: Please connect the DC5.5 round port to 2-pin converter cable when you are using AC 24V power. Please use according to device tag.

Please refer to the follow sheet for detailed pin information.

Port Name	SN	Name	Note
I/O Port	1	ALARM_NO	Alarm output port. It is to output the alarm signal to the alarm device. NO: normal open alarm output port. It must be used with ALARM_COM.
	2	ALARM_COM	Alarm output public port.
	3	ALARM_IN1	Alarm input port 1. It is to receive the on-off signal from the external alarm source.
	4	ALARM_IN2	Alarm input port 2. It is to receive the on-off signal from the external alarm source.
	5	GND	Ground port

1.2 Framework and Dimension

Note:

The following figure is for reference only, which is used to know the device dimension.

Please refer to the following figure for dimension information. The unit is mm. See Figure 1- 2.

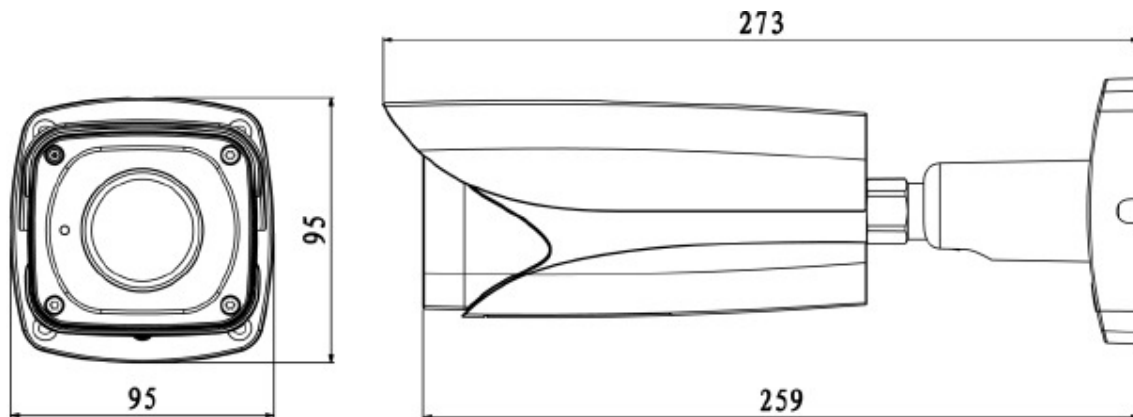

Figure 1-2

1.3 Alarm Setup

Note:

It is only supported by some series products.

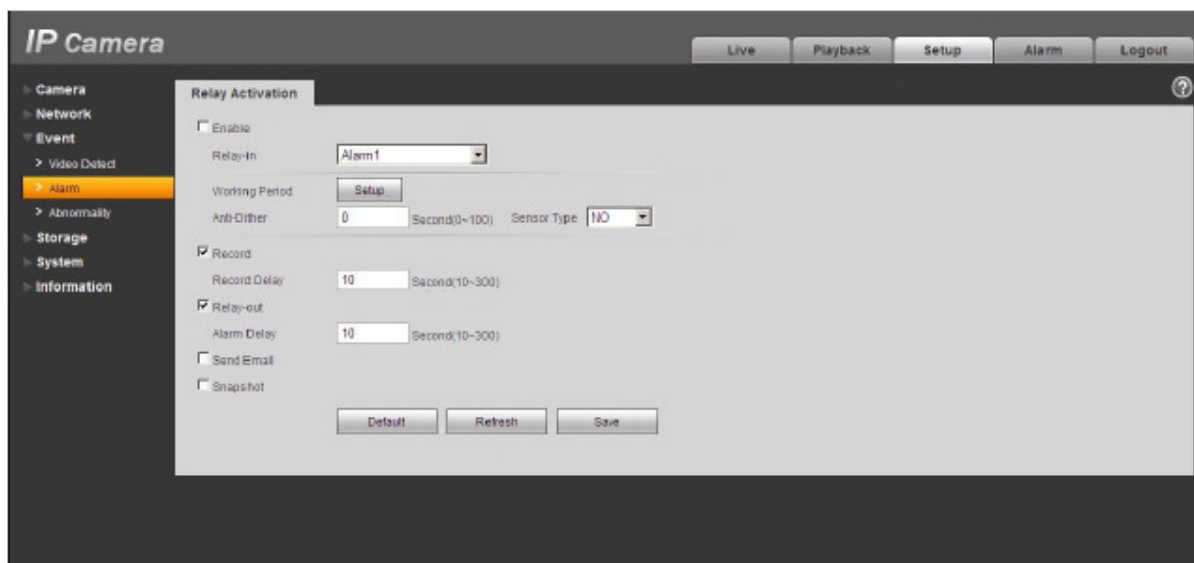

Figure 1-3

Alarm input, output description:

Step 1

Connect alarm input device to the alarm input of I/O port cable.

Step 2

Connect alarm output device to the ALARM_OUT and ALARM_OUT_GND of I/O port cable, Alarm output is the relay switch output; alarm output port can only be connected to NO (normally open) alarm device.

Step 3

Open the WEB, set alarm input and output correspondingly in alarm setup. Alarm input on the WEB is corresponding to that of the device I/O port cable. When there is alarm, alarm input device will generate signal of high and low level. Set corresponding NO and NC inputs.

Step 4

Set alarm output on the WEB, the alarm output is corresponding to the alarm output end of the device, this is the alarm output port of the I/O port cable.

Please refer to the following figure for alarm input and output information. See Figure 1-4. Alarm input: When the input signal is idle or grounded, the device can collect the different statuses of the alarm input port. The input signal is connected to 3.3V or is idle; the device collects the logic "1". When the input signal is grounded, the device collects the logic "0".

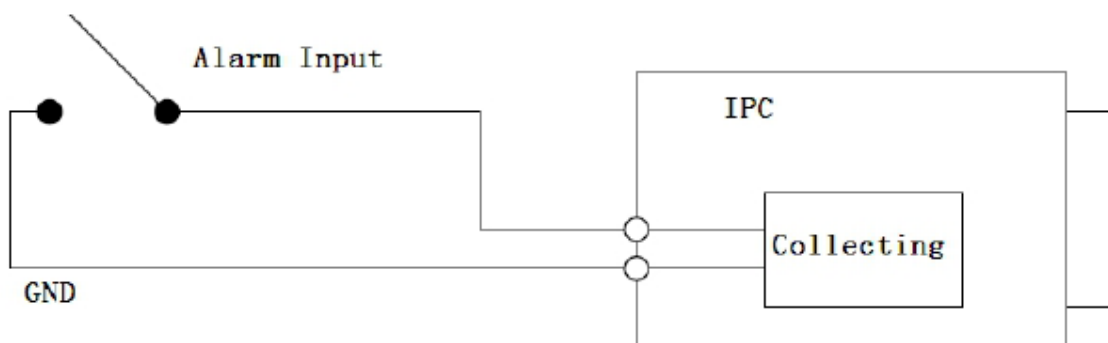
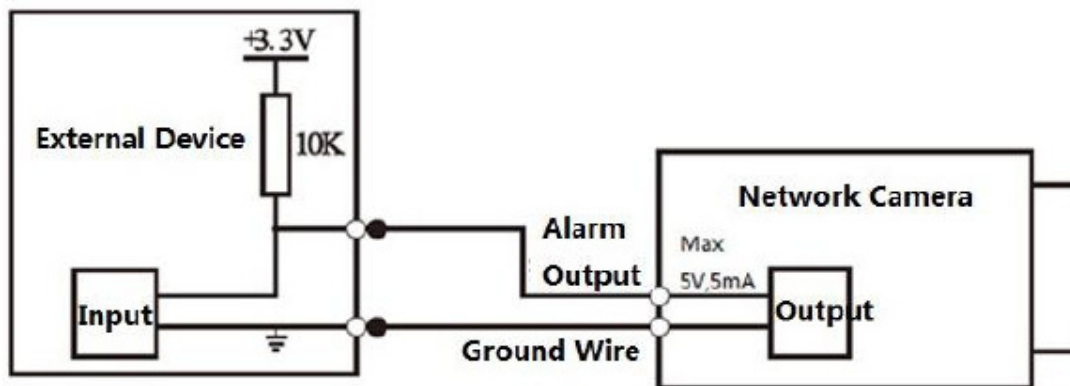

Figure 1-4

Please refer to the following figure for alarm output information. See Figure 1-5 and Figure 1-6.



A

Figure 1-5

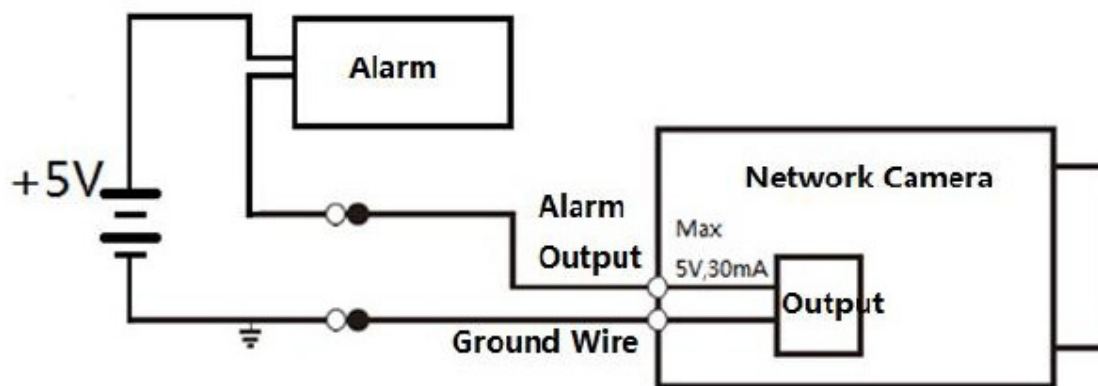

B

Figure 1-6

Mode A:

Level application. Alarm output high and low level, alarm output is OC; it needs to increase pull-up resistance externally to work normally. Max external pull-up level is 5V, max port current is 5mA. After external pull-up resistance is increased, the default of output signal is high level (external pull-up voltage), and it switches to low level when there is alarm output (when the working current is 5mA, output voltage is less than 0.8V).

Mode B:

Switch application. Alarm output is used to drive external circuit, max current is 30mA, max voltage is 5V, it is advised to add a relay if it is beyond the value.

2 Device Installation

Important

Please make sure the installation surface can support the 3X weight of the camera and the bracket.

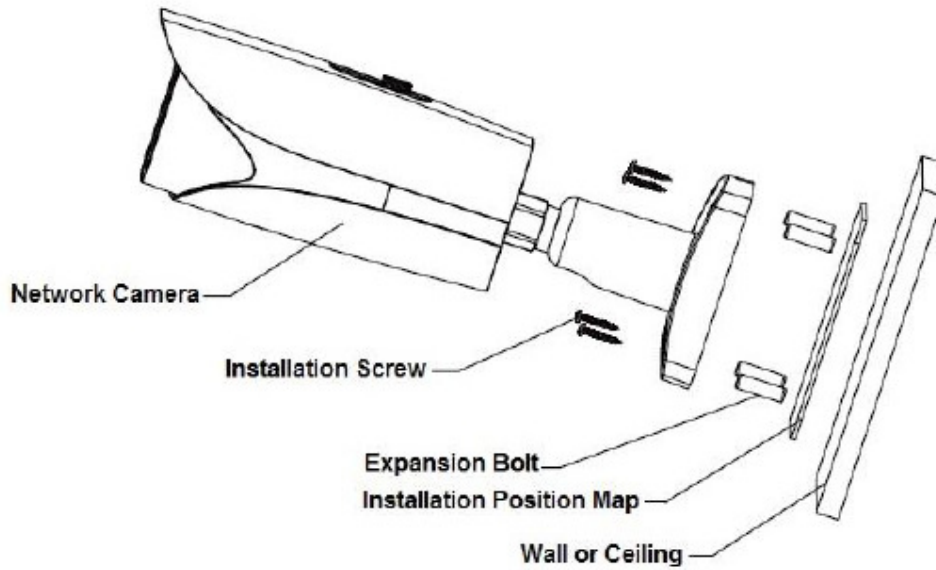

Figure 2-1

Please see Figure 2-1.

Step 1

SD card installation (Optional)

- User may see the SD installation card slot, analog output; two direction button and reset button after you open the lower cover.
- Insert the SD card into the slot which is shown in Figure 2-2, user may press the SD card slightly to insert it because the card slot is elastic.

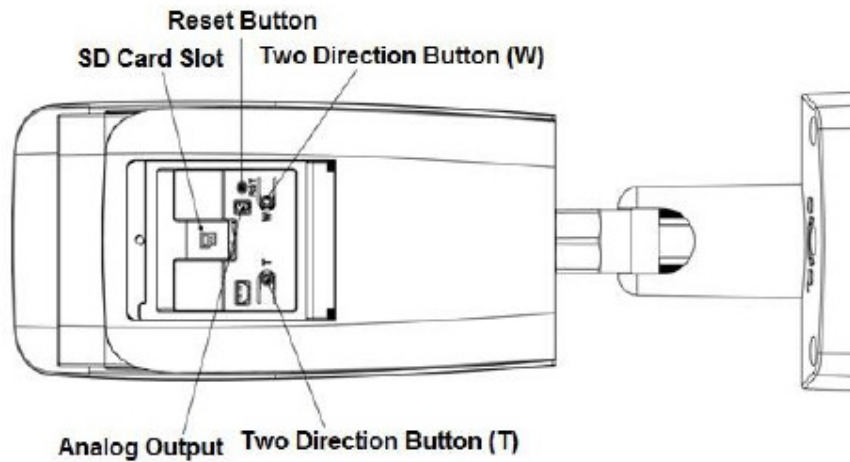

Figure 2-2

Note:

- Motorized vari-focal series devices are equipped with motorized lens by default, which doesn't need manual adjustment; meanwhile the devices with two direction buttons support zoom and focus via the two direction buttons on the panel.
- User may connect the analog output port to the TV monitor to check image via analog output cable.
- Press the reset button for 4 to 5 seconds to realize reset function for the device.

Step 2

Stick the installation position map on the designated surface where you will install the device (wall or ceiling), then dig holes according to hole location marked on installation map.

Step 3

Open the accessories bag, take out expansion bolt and insert it into the hole you just dug.

Step 4

Open the accessories bag, take out screws. Tighten the 4 screws to fix the device on the installation surface (wall or ceiling). User may move the device sunshield back and forth. When you have fixed the device, you must tighten screws on sunshade.

Step 5

Plug the external cables of the device properly according to the use requirements.

Step 6

Adjust the monitoring direction of the device.

Note:

- The location of the adjusting screw may be different due to different models, please refer to the actual product for more details.
- Please be sure to loosen the adjusting screw when adjusting the device position and angle, tighten the adjusting screw after adjustment.
- The continuous rotation toward the same direction for the camera body has to be within 3 circles.
- The lower cover can't be opened for a long time, besides; it can't be opened in the humid environment in case water mist and fog problem may happen to the device.

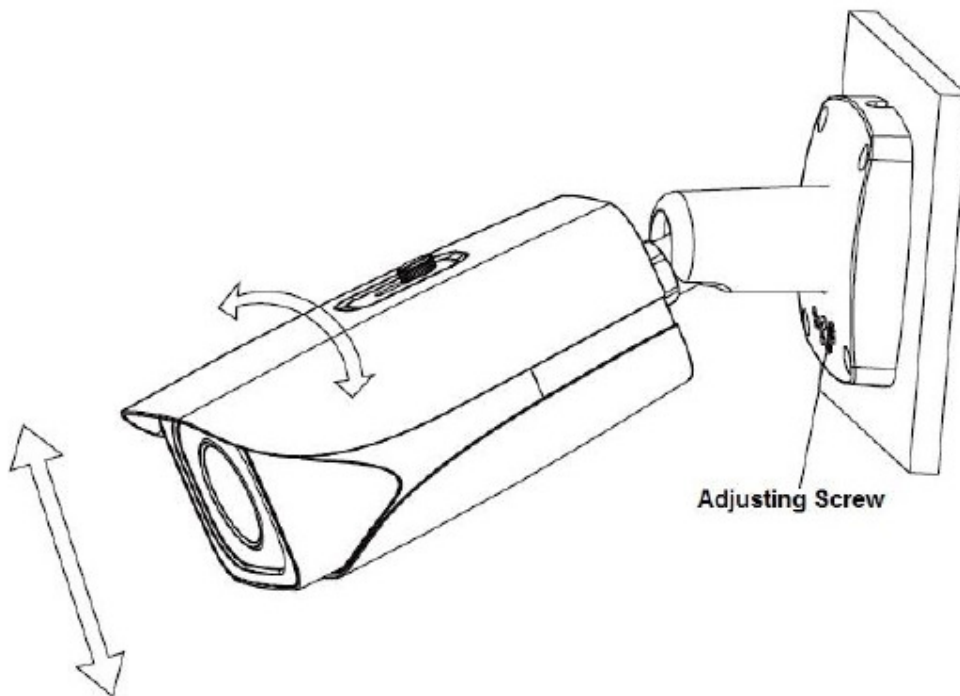

Figure 2-3

1. Use screwdriver (in accessories bag) to loosen adjusting screw.
2. Adjust the device in all possible directions, and set its monitoring direction according to use requirement.
3. Use screwdriver to tighten the adjusting screws.

Step 7

Waterproof connector installation for network port; see Figure 2-4 for more details.

Note:

Please implement this step if the device is equipped with network port waterproof connector and it is used outdoors.

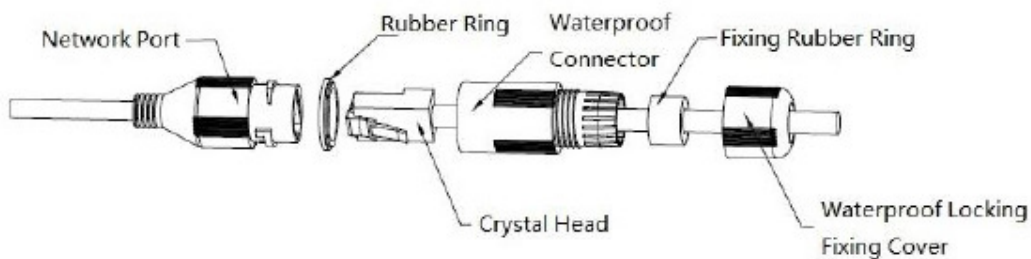

Figure 2-4

1. Keep the convex groove outward and install the rubber ring into the network port, keep the smaller hole of the rubber ring outward and install the fixing rubber ring into the main body of the waterproof connector.
2. Pull the network cable without crystal head through main body of waterproof connector, fixing rubber ring and waterproof locking cover, make the crystal head of network cable, and then insert it into the network cable.

3. Put the main body of waterproof connector on the network port and rotate it clockwise to lock the network port and waterproof connector firmly.
4. Put the waterproof locking cover on the main body of waterproof connector and rotate it clockwise to lock the waterproof connector and waterproof locking cover firmly.

3 Network Configuration

The IP address of all the cameras is the same when leaving factory (default IP192.168.1.108), in order to make the camera get access to the network smoothly, please plan the useable IP segment reasonably according to the actual network environment.

3.1 Modify IP Address

IP address can be acquired and modified through quick configuration tool for the cameras which are accessed via wired network, it needs to connect wired network to configure wireless parameters before using wireless network cameras. In this chapter, it will introduce the approach of modifying IP address via “Quick Configuration Tool”; also user may modify the IP address in the network parameters of the WEB interface, please refer to the document in the disk << WEB Operation Manual>> for more details.

Note:

Currently the quick configuration tool only supports the cameras which apply to the same network segment with computer IP address.

Step 1 Double click the “ConfigTools.exe” and open the quick configuration tool.

Step 2 Double click the device to be configured, the system will pop out the “Login” dialog box.

Enter the IP address, user name, password and port number of the camera, and click “Confirm”.

Note:

The default user name and password are admin and admin respectively, the default of port is 37777. See Figure 3-1 for more details.

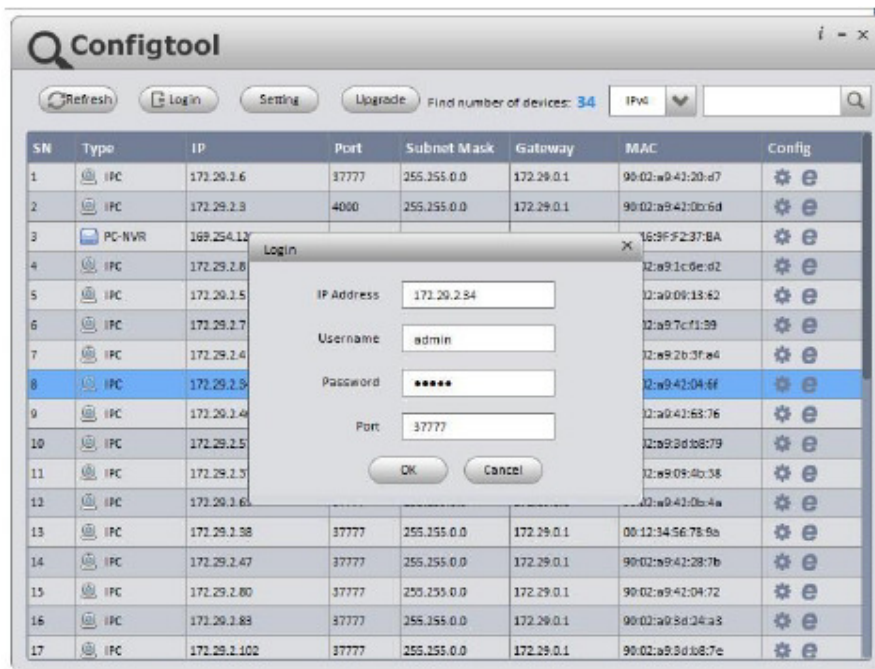

Figure 3-1

Step 3 Modify the camera IP address on the “Net” interface, click “Save” to finish modification.

See Figure 3-2 for more details.

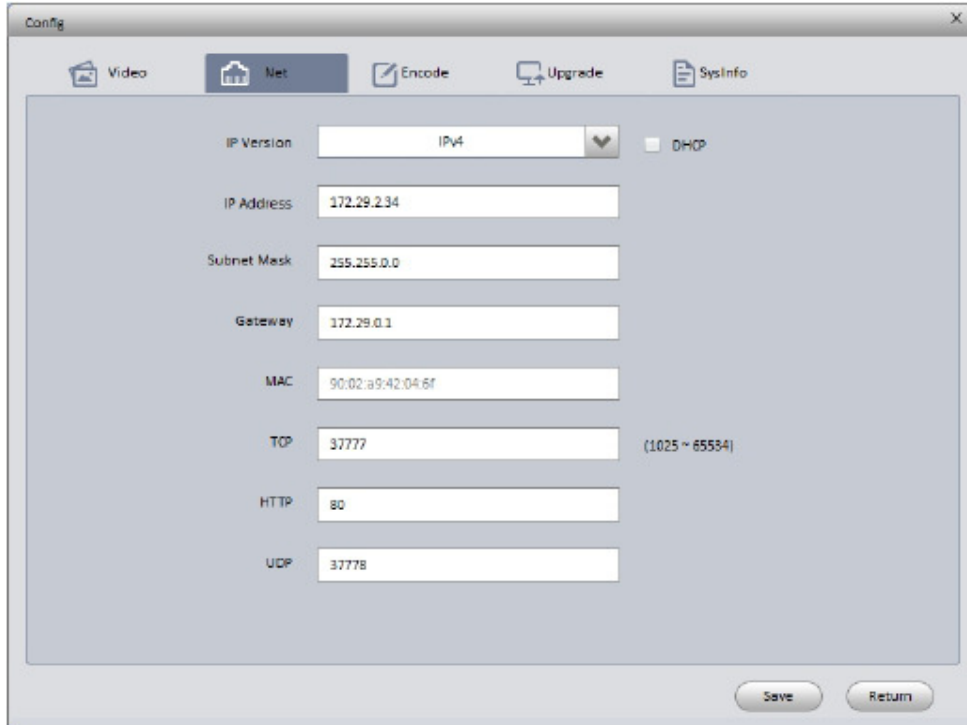

Figure 3-2

3.2 Login WEB Interface

Note:

Different devices may have different WEB interfaces, the figures below are just for reference, please refer to the document <<WEB Operation Manual>> in the disk and the actual interface for more details

Step 1 Open IE and input the modified camera IP address in the address bar.

Step 2 The login interface is shown below, please input your user name and password (Default user name is admin and password is admin respectively), click "login".

See Figure 3-3 for more details.



Figure 3-3

Step 3 Install controls according to the system prompt; see Figure 3-4 for the WEB main interface. Please modify the administrator password as soon as possible after you successfully logged in.

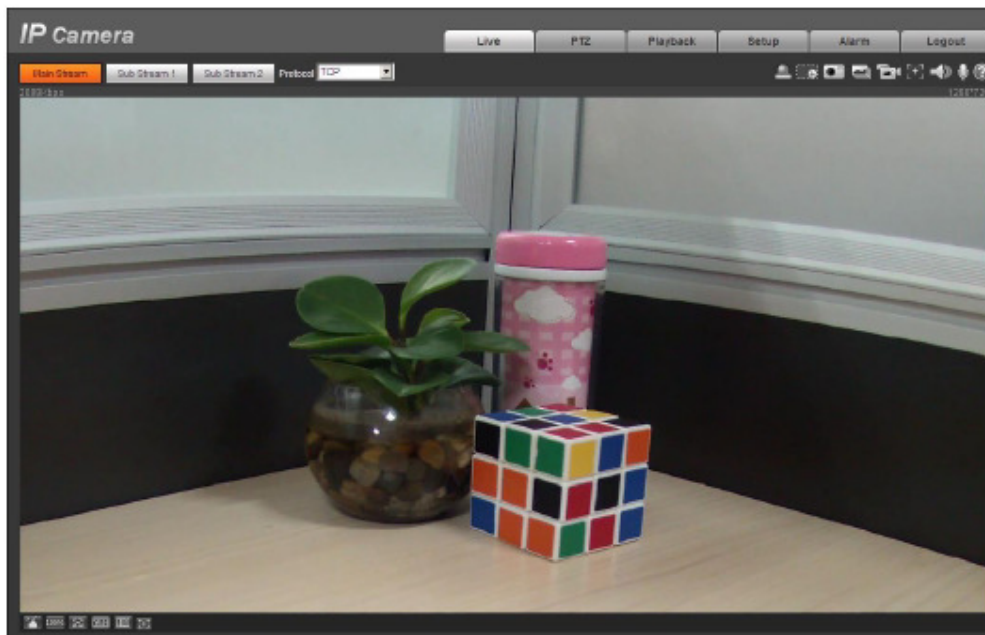

Figure 3-4

Note:

- **This quick start guide is for reference only. Slight difference may be found in user interface.**
- **All the designs and software here are subject to change without prior written notice.**
- **If there is any uncertainty or controversy, please refer to the final explanation of us.**
- **Please visit our website or contact your local service engineer for more information.**

Table of Contents

1	Network Config.....	1
1.1	Network Connection	1
1.2	Log in	1
2	Live.....	6
2.1	Encode Setup	6
2.2	System Menu.....	7
2.3	Video Window Function Option	7
2.4	Video Window Setup	8
2.4.1	Image Adjustment.....	8
2.4.2	Original Size	9
2.4.3	Full Screen	9
2.4.4	Width and Height Ratio	10
2.4.5	Fluency Adjustment.....	10
2.4.6	Rules Info	10
2.4.7	Zoom and Focus	10
2.4.8	Fisheye/Trigger Track	10
3	PTZ Control.....	15
3.1	Scan	16
3.2	Preset.....	17
3.3	Tour.....	17
3.4	Pattern	18
3.5	Assistant	19
3.6	Light Wiper	19
4	Playback.....	20
4.1	Playback.....	20
4.1.1	Function of Play.....	21
4.1.2	Playback File	22
4.1.3	Playback Cut.....	24
4.1.4	Record Type	24
4.1.5	Progress Bar.....	24
4.1.6	Assistant Function	25
4.2	Picture Playback	25
4.2.1	Play	26
4.2.2	Playback File	26
4.2.3	Snapshot Type	28
5	Setup.....	30
5.1	Camera	30

5.1.1	Conditions.....	30
5.1.2	Video	41
5.1.3	Audio	53
5.2	Network.....	56
5.2.1	TCP/IP	56
5.2.2	Connection.....	58
5.2.3	PPPoE	60
5.2.4	DDNS	61
5.2.5	IP filter.....	62
5.2.6	SMTP (e-mail).....	63
5.2.7	UPnP	64
5.2.8	SNMP	65
5.2.9	Bonjour	68
5.2.10	Multicast	68
5.2.11	4G	69
5.2.12	WIFI.....	71
5.2.13	802.1x	73
5.2.14	QoS	74
5.2.15	HTTPs.....	75
5.3	Event.....	85
5.3.1	Video detection.....	85
5.3.2	Audio Detection.....	92
5.3.3	Smart Plan.....	94
5.3.4	Intelligence Behavior Analytics	94
5.3.5	Face Detection	102
5.3.6	People Counting	104
5.3.7	Heat Map	106
5.3.8	Alarm	109
5.3.9	Abnormity.....	113
5.4	Storage Management.....	116
5.4.1	Schedule.....	116
5.4.2	Destination.....	120
5.4.3	Record control	122
5.5	System	123
5.5.1	General.....	123
5.5.2	Account.....	126
5.5.3	PTZ	129
5.5.4	Default	130
5.5.5	Import/Export	131

5.5.6	Remote control	131
5.5.6	Auto Maintenance.....	132
5.5.7	Upgrade	133
5.6	Information	133
5.6.1	Version.....	133
5.6.2	Log.....	134
5.6.3	Online User.....	134
6	Alarm.....	136
7	Log out.....	138

Important

The following functions are for reference only. Some series products may not support all the functions listed below.

1 Network Config

1.1 Network Connection

Network camera and PC connection mainly has two ways, see Figure 1- 1 and Figure 1-2.

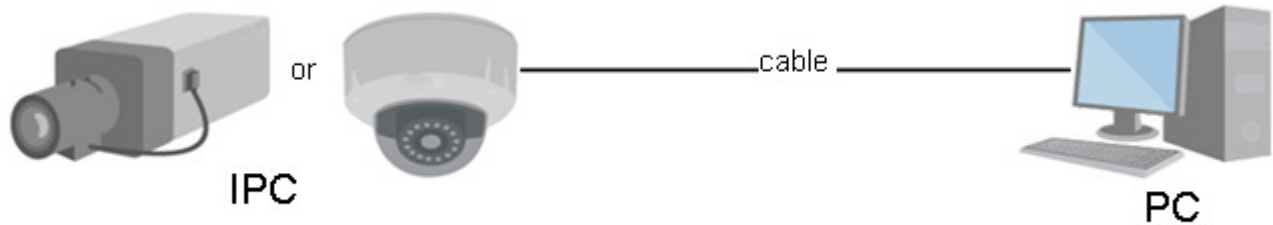

Figure 1- 1

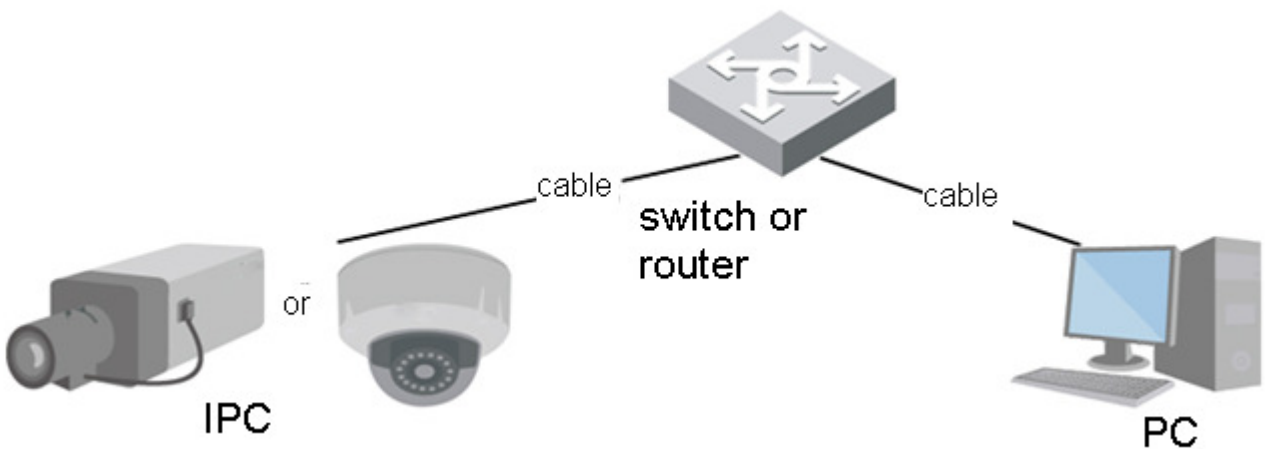

Figure 1-2

Before you access network camera via the Internet, you need to have its IP address. User can use Config Tool to search IP of the network camera. Please refer to Config Tool manual.

1.2 Log in

It needs to install WEB plug-in when you use WEB client for the first time, the exact operation steps are shown as follows:

Open IE and input network camera address in the address bar. (The factory default IP address is 192.168.1.108).

After successful connection, the login interface is shown as in Figure 1-3; input your user name and password. Default factory username is **admin** and password is **admin**.



Figure 1-3

The system will display "Update Password" prompt box for your first login, users need to modify the password and save it properly.

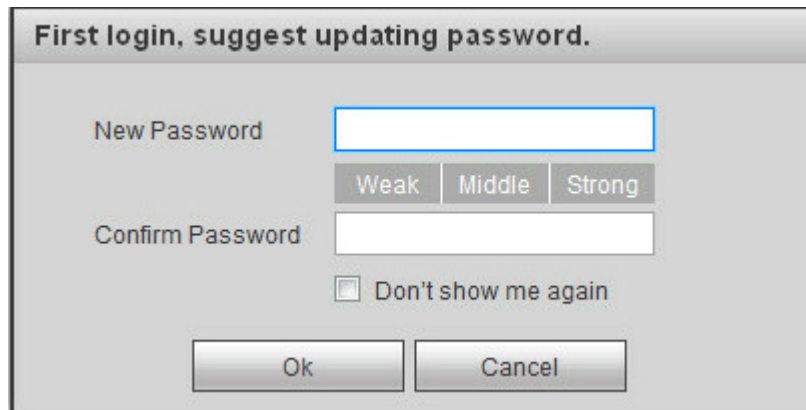

Figure 1-4

After successful login, you may see the interface shown as in Figure 1-5.

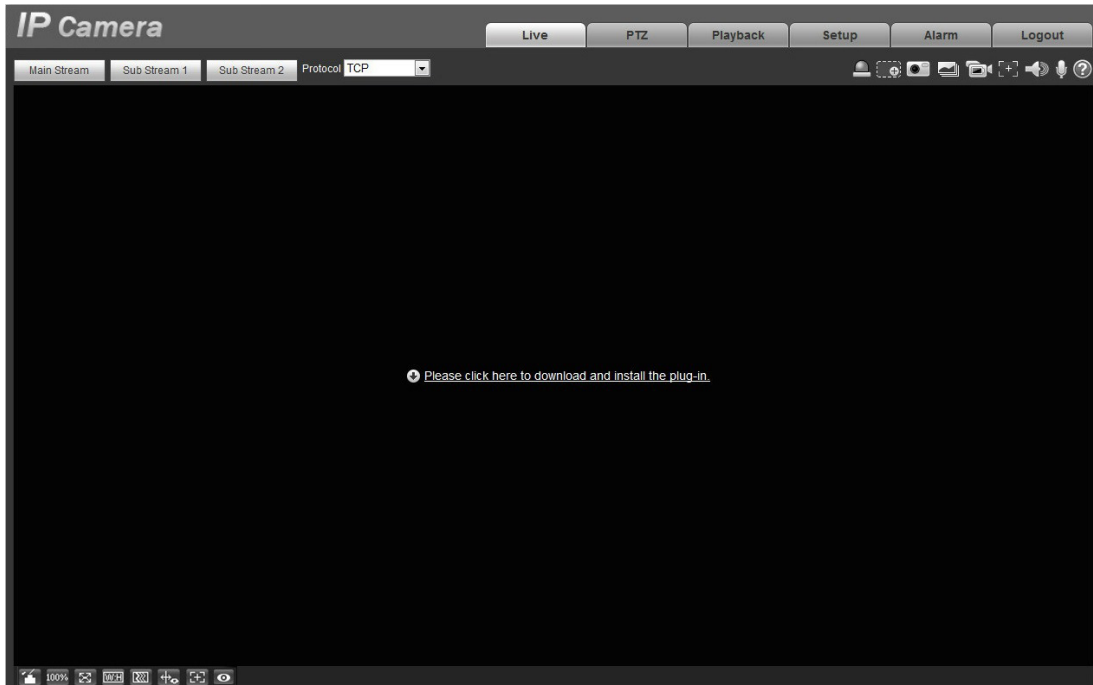

Figure 1-5

Click on "Please click here to download and install the plug-in". The system pops up warning information to ask you whether run or save this plug-in. See Figure 1-6.



Figure 1-6

You must either run or save the file to local and install it. Follow the following steps. Click on run, you will see Figure 1-7 and Figure 1-8.

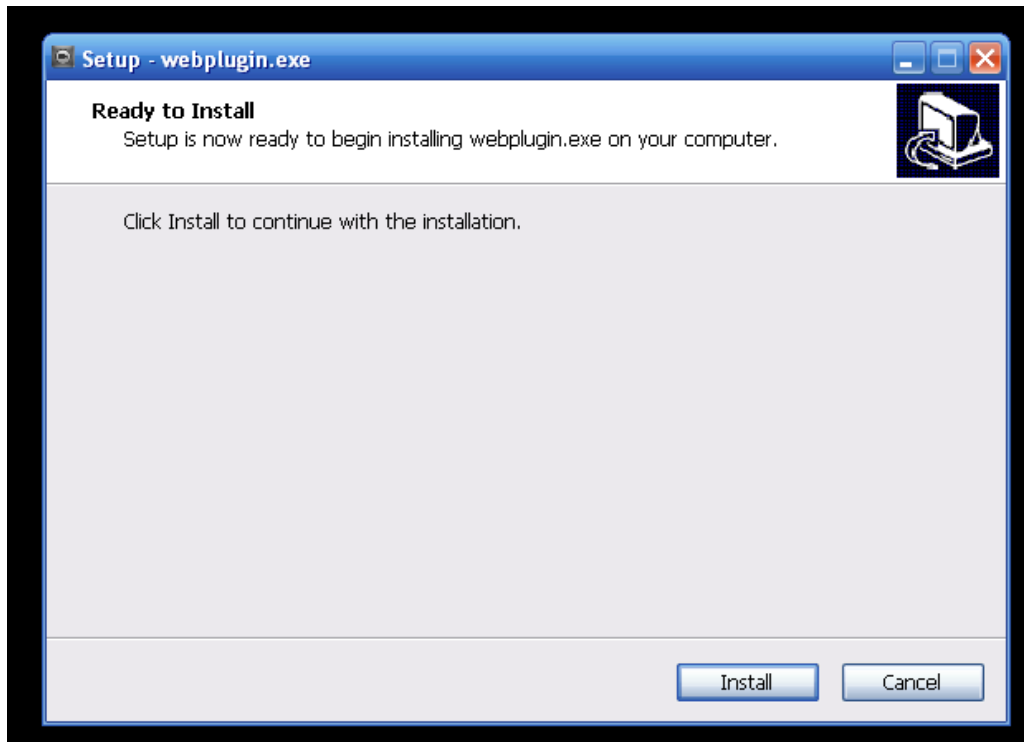

Figure 1-7

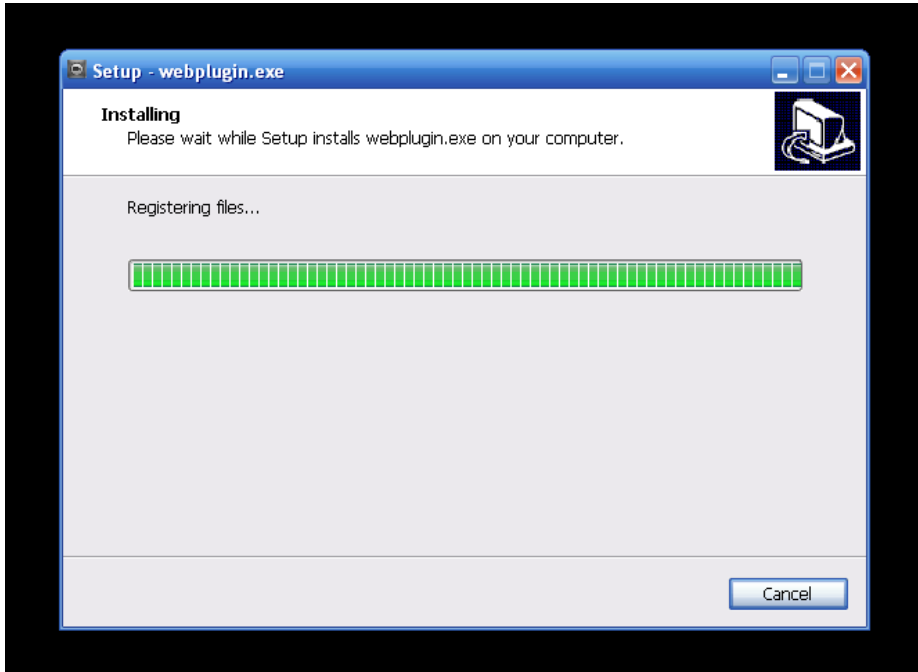

Figure 1-8

When plug-in installation completes, the installation page closes automatically. The web-end will refresh automatically, and then you can view video captured by the camera.

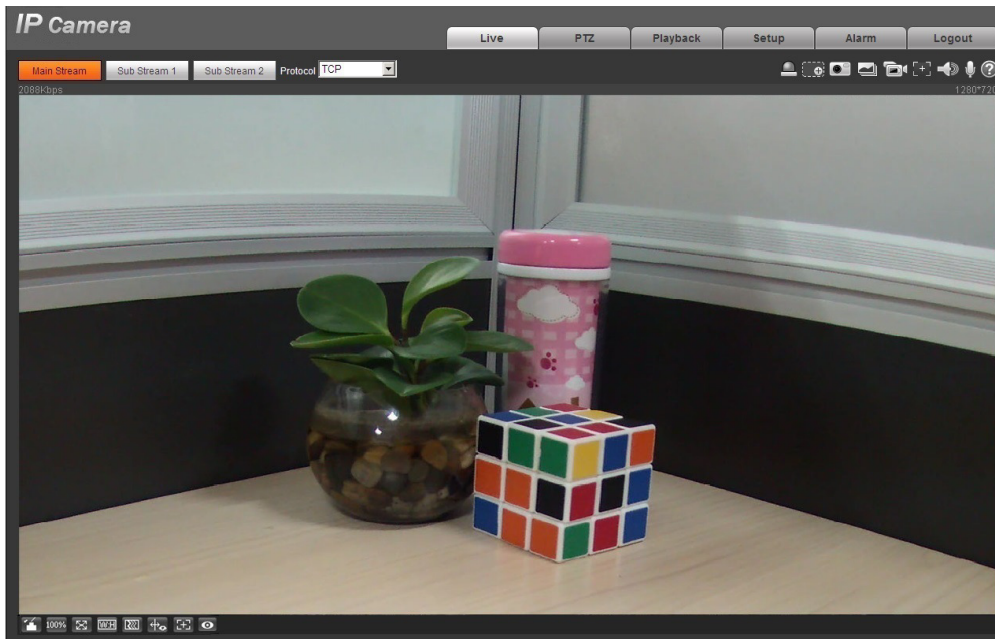

Figure 1-9

2 Live

After you logged in, you can see the live monitor window. See Figure 2-1.

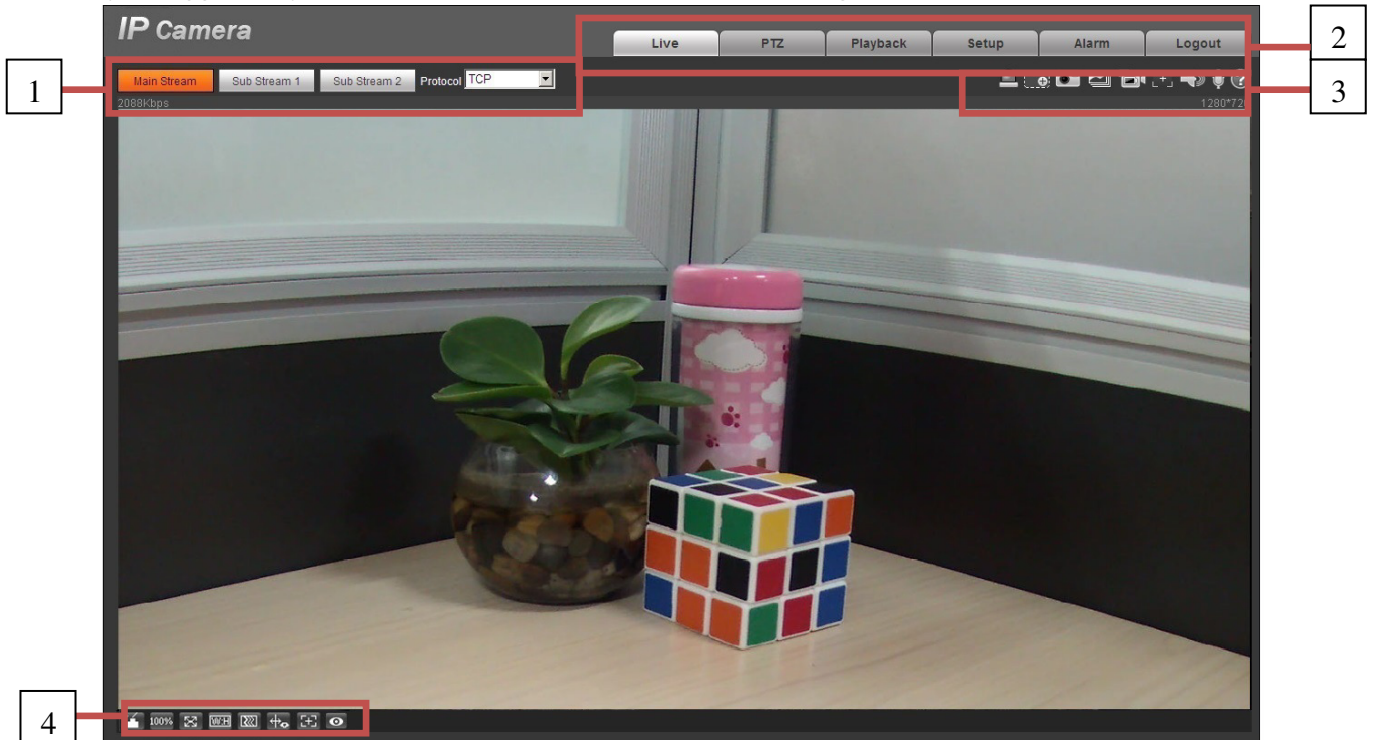

Figure 2-1

There are four sections:

- Section 1: Encode setup bar
- Section 2: System menu
- Section 3: Window function option bar
- Section 4: Window adjust bar

2.1 Encode Setup

Note: Some series don't support sub stream 2.

The encode setup interface is shown as in Figure 2-2.

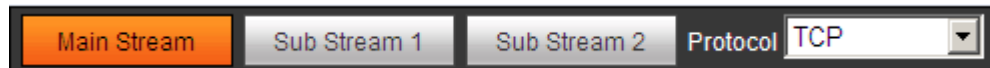

Figure 2-2

Please refer to the following sheet for detailed information.

Parameter	Function
Main stream	Click it to enable main stream video monitoring and click again to disable it. Generally for storage and monitor.
Sub Stream 1	Click it to enable Sub Stream 1 video monitoring and click again to disable it. When network bandwidth is insufficient, it substitutes main stream for monitoring.
Sub Stream 2	Click it to enable Sub Stream 2 video monitoring and click again to disable it. When network bandwidth is insufficient, it substitutes main stream for monitoring.
Protocol	You can select stream media protocol from the dropdown list. There are three options: TCP/UDP/Multicast

2.2 System Menu

System menu is shown as in Figure 2-3.

Please refer to chapter 2 Live, chapter 3 PTZ, chapter 4 Playback, chapter 5 Setup, chapter 6 Alarm, chapter 7 Log out for detailed information.



Figure 2-3

2.3 Video Window Function Option

The interface is shown as below. See Figure 2-4.



Figure 2-4

Please refer to the following sheet for detailed information.

SN	Parameter	Function
1	Relay-out	It shows if there is any alarm output, status description is as follows: <ul style="list-style-type: none"> ● Red: means there is alarm output. ● Grey: means alarm is over. Click on the button to force alarm to be on or off.

2	Digital Zoom	<ul style="list-style-type: none"> ● When the video is in the original status, click it you can select any zone to zoom in. In the non-original status, you can drag the zoom-in zone in specified range. Right click mouse to restore previous status. ● Click it; you can use the middle button of the mouse to zoom in/out the video size.
3	Snapshot	Click on the button to snapshot, save picture to path in Ch. 5.1.2.5.
4	Triple snapshot	Click it to take snapshot upon the video at the frequency of one picture per second. All images are saved to path in Ch 5.1.2.5.
5	Record	Click it to record the video. All videos are saved to path in Chapter 5.1.2.5.
6	Easy focus	<p>Click it, you can see there are two parameters on the preview video: AF Peak and AF Max.</p> <p>AF Peak: It is to display the video definition during the focus process.</p> <p>AF Max: It is the most suitable value for the video definition.</p> <p>The close the AF Peak and AF Max is, the better the focus effect is.</p>
7	Audio	Turn on or off audio when you are monitoring.
8	Talk	Click it to start or end bidirectional talk.
9	Help	Click it to open help file.

2.4 Video Window Setup

The interface is shown as in Figure 2-5.

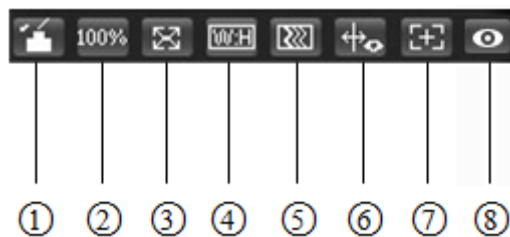

Figure 2-5

2.4.1 Image Adjustment

See Figure 2-6 for image adjustment.

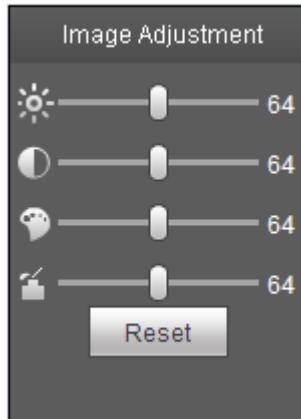

Figure 2-6

Click this button to display/hide image control interface. Click it to open picture setup interface. This interface is on the top right pane.

Please refer to the following sheet for detailed information.

Parameter	Function		
Video setup		It is to adjust monitor video brightness.	Note: <ul style="list-style-type: none"> ● All the operations here apply to WEB end only. ● Please go to Setup->Camera->Conditions to adjust corresponding items.
		It is to adjust monitor video contrastness.	
		It is to adjust monitor video hue.	
		It is to adjust monitor video saturation.	
	Reset	Restore brightness, contrastness saturation and hue to system default setup.	

2.4.2 Original Size

Click this button to go to original size. It is to display the actual size of the video stream. It depends on the resolution of the bit stream.

2.4.3 Full Screen

Click it to go to full-screen mode. Double click the mouse or click the Esc button to exit the full screen.

2.4.4 Width and Height Ratio

Click it to restore original ratio or suitable window.

2.4.5 Fluency Adjustment

There are three levels of fluency for you to select (Realtime, Normal, and Fluency). The default is normal.

2.4.6 Rules Info

Click the button, preview image will display intelligent rules after enabling; it is “enable” by default.

2.4.7 Zoom and Focus

Click this button and the focus zooming interface appears on the right of preview interface, as shown in Figure 2-7, click left mouse button to adjust focus zooming configuration.

Note:

- The product series which support motorized zoom, synchronous focus and back focus have this button.
- Auto-focus after zoom and focus adjustment.

2.4.8 Fisheye/Trigger Track

Click the button, installation mode and display mode interface will show up on the right of the preview interface, see Figure 2-8 and Figure 2-9, single click to switch different installation modes and display modes for fisheye, or switch different display modes for trigger track, it is enabled by default.

Note:

It is only supported by some models.

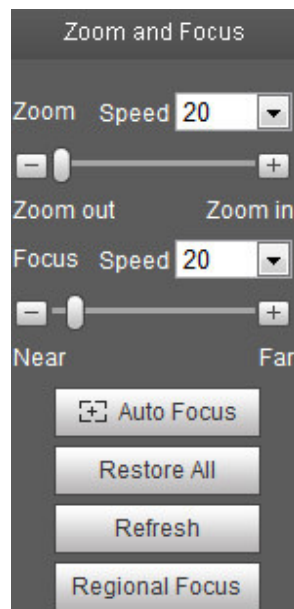

Figure 2-7

Parameter	Function
Zoom	Adjust the focal length of the lens by clicking or long pressing “+”“-”buttons. The speed is used to adjust the length of one step during single click.
Focus	Adjust the sharpness of the lens by clicking or long pressing“+”、“-” buttons. Step length is used to adjust the length of one step with one click.
Auto-focus	Click to adjust the image definition automatically. Note: Other lens operations are not allowed during the process of auto-focus.
Reset All	Reset the lens to zero position to eliminate the accumulative error of lens. Note: Please reset when the image adjustment is not clear or operating zoom focus many times.
Refresh	Synchronize the location of drag slider of lens and zoom focus after hardware zoom focusing.
Regional Focus	Click it and use the mouse to select a zone, then the device can auto focus within the specific region.

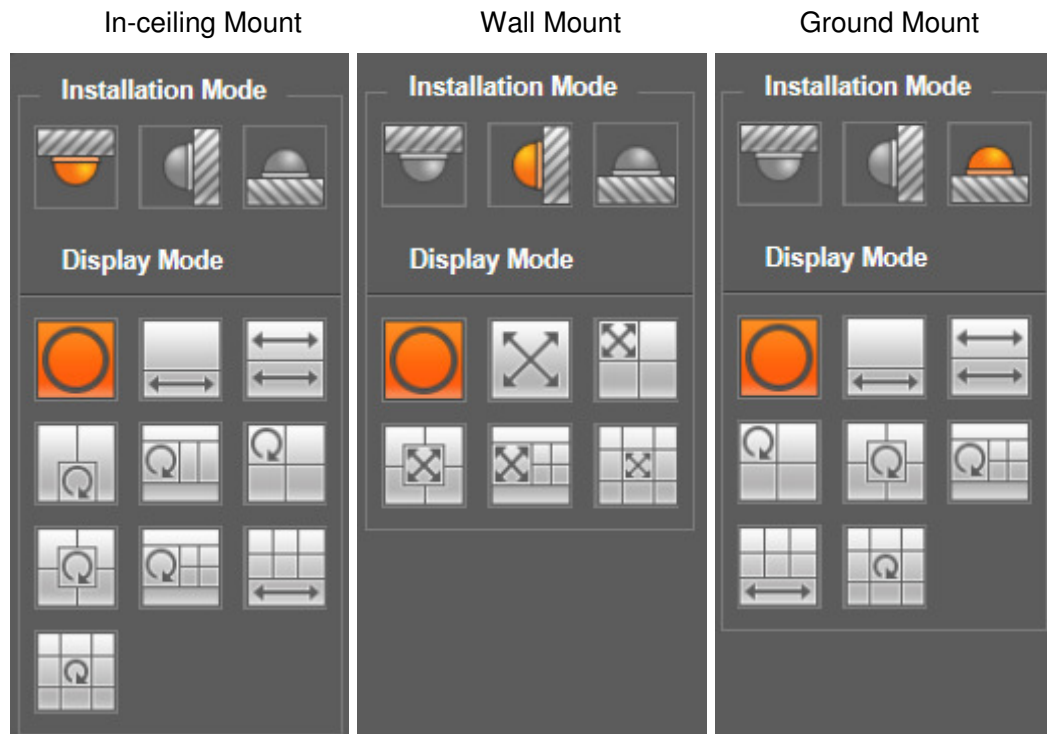



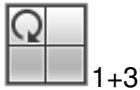









Figure 2-8

parameter	Note	
Installation Mode	Three modes which are ceiling mount, wall mount and ground mount.	
Display Mode	<p>It represents the display mode of the current image (default supports original image mode), the display modes may be different according to different installation modes. It is shown as follows:</p> <ul style="list-style-type: none"> • Ceiling: 1P+1、 2P、 1+2、 1+3、 1+4、 1P+6、 1+8。 • Wall: 1P、 1P+3、 1P+4、 1P+8。 • Ground: 1P+1、 2P、 1+3、 1+4、 1P+6、 1+8。 <p>Note: The default displays original image mode when switching installation mode.</p>	
In-ceiling/Wall/Ground		It means the original image without de-warpping
In-ceiling/Ground		360°expanded rectangular panorama + independent sub image, the sub image and the subbox in the expanded rectangular panorama support zoom and movement, for the expanded rectangular panorama also supports left and right starting point movement.
		Two related 180° expanded rectangular pictures, two subwindows form 360° panorama anytime, which is also called “dual panorama”. Two expanded rectangular pictures both support left and right movement starting point, which are also linked by eachother.
		Original image + 2 independent sub images, both the sub image and the subbox in the original image support zoom and movement. The original image also supports changing starting point by rotation (no such display mode for ground installation).
		Original image + 2 independent sub images, both the sub image and the subbox in the original image support zoom and movement. The original image also supports changing starting point by rotation
		Original image + 4 independent sub images, both the sub image and the subbox in the original image support zoom and movement. The original image also supports changing starting point by rotation

parameter	Note
	 1P+6 360° expanded rectangular panorama +6 independent sub image, both the sub image and the subbox in the expanded rectangular panorama support zoom and movement, for the expanded rectangular panorama also supports left and right starting point movement.
	 1+8 Original image + 8 independent sub images, both the sub image and the subbox in the original image support zoom and movement. The original image also supports changing starting point by rotation
Wall	 1P From left to right 180° expanded rectangular panorama, which supports up and down movement and changes vertical angle of view.
	 1P+3 180° expanded rectangular panorama+3 independent sub images, both the sub images and the sub box in the expanded rectangular panorama support zoom and movement, expanded rectangular panorama supports up and down movement and changes vertical angle of view.
	 1P+4 180° expanded rectangular panorama+4 independent sub images, both the sub images and the sub box in the expanded rectangular panorama support zoom and movement, expanded rectangular panorama supports up and down movement and changes vertical angle of view.
	 1P+8 180° expanded rectangular panorama+8 independent sub images, both the sub images and the sub box in the expanded rectangular panorama support zoom and movement, expanded rectangular panorama supports up and down movement and changes vertical angle of view.

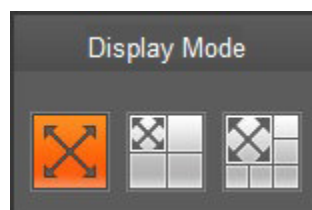





Figure 2-9

Enable the trigger track on the interface of tripwire or intrusion, and draw the rule of tripwire or intrusion, the scene of trigger track window will change according to the moving object when it triggers rule alarm until the moving object disappears from the view range of the camera. Please refer to “5.3.4 IVS” for more details about the rules drawing and parameter config of tripwire and intrusion.

Trigger track includes three modes which are 1P, 1P+3 and 1P+5.

-  1P: Original picture
-  1P+3: Original picture and three trigger track windows, it can adjust the location and size of three trigger track windows on the original picture.
-  1P+5: Original picture and five trigger track windows, it can adjust the location and size of five trigger track windows on the original picture.

3 PTZ Control

Here you can view direction keys, speed, zoom, focus, iris, preset, tour, pan, scan, pattern, aux on, off and PTZ setup button. See Figure 3-1.

Note:

Before PTZ operation, please make sure you have properly set PTZ protocol. (Please refer to Ch. 5.5.3). Currently only IPC-HFXXXX series and –PT series products can support PTZ function.

Parameter	Note
PTZ direction	<ul style="list-style-type: none"> PTZ supports eight directions: left/right/up/down/upper left/upper right/bottom left/bottom right.
Speed	It controls rotation speed. The longer the step length, the higher the speed. Step length control PTZ, zoom, focus and iris.
 Quick Position	Use mouse to draw a box in monitoring video, PTZ will rotate and focus to quickly positioning.

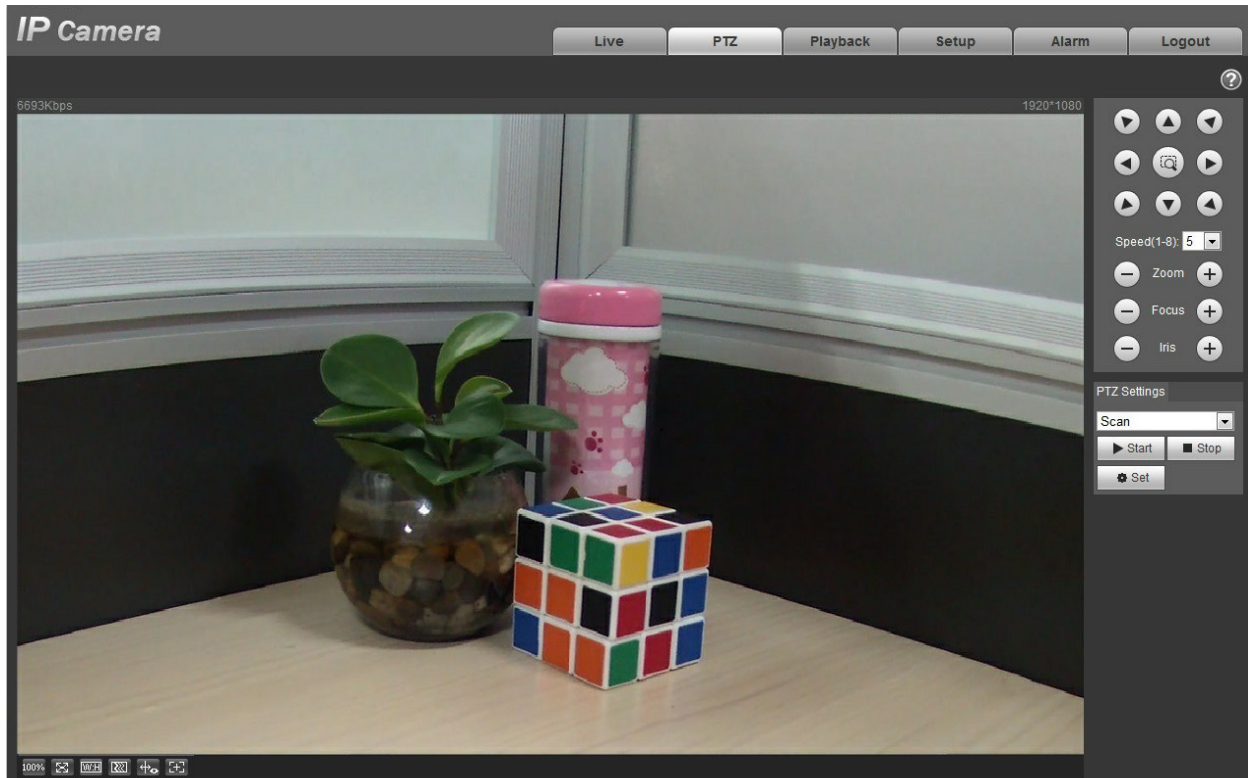

Figure 3-1

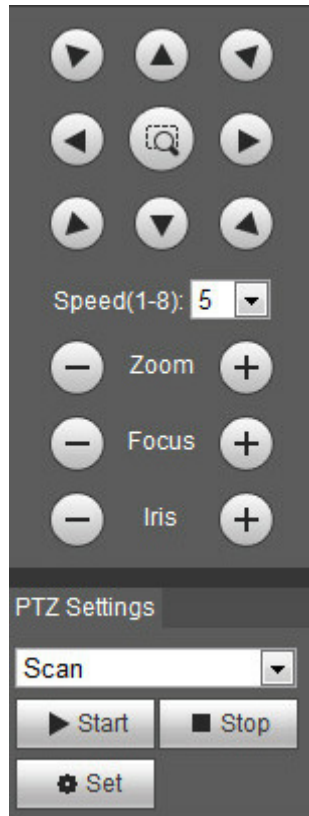

Figure 3-2

PTZ setting interface is shown as in Figure 3-3.

Here you can set scan, preset, tour, pattern, assistant function and light and wiper plus view coordinate.

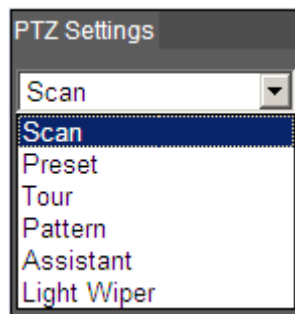

Figure 3-3

3.1 Scan

Scan interface is shown in Figure 3-4.

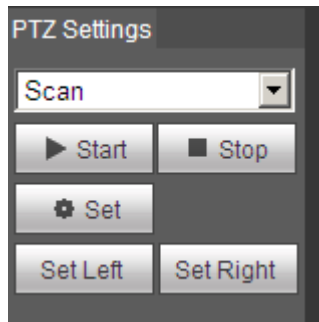



Figure 3-4

Steps to scan are:

- Step 1. Click on Set button, display  icon.
- Step 2. Move via direction key to select left, click on Set Left to set left border of camera
- Step 3. Move via direction key to select right, click on Set Right to set right border of camera.
- Step 4. Complete scan path setup.

3.2 Preset

Preset interface is shown in Figure 3-5.

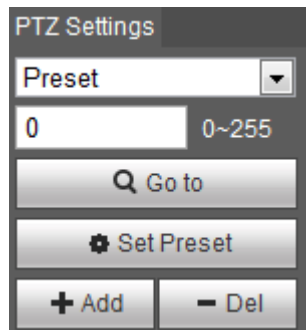

Figure 3-5

Steps to preset are:

- Step 1. In preset box, input preset value.
- Step 2. Click on Go to, camera rotates to preset position.
- Step 3. Use direction key to rotate camera, and in preset box input preset value.
- Step 4. Click on Add to add a preset. Range of preset relates to PTZ protocol.

3.3 Tour

Tour interface is shown in Figure 3-6.

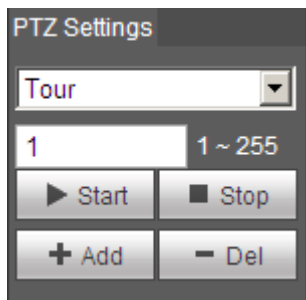

Figure 3-6

Steps to tour are:

Step 1. In tour box, input tour path value.

Step 2. Click on Add. Range of tour relates to PTZ protocol.

Step 3. In preset box, input preset value.

Step 4. Click on Add as to add a preset in this tour. If click on Del, it deletes this preset in tour.

Note:

You can add more than one preset here, or delete more than one preset.

3.4 Pattern

Pattern interface is shown in Figure 3-7.

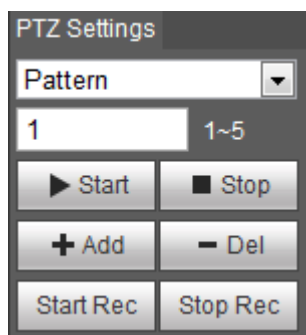

Figure 3-7

Steps to set pattern are shown as follows:

Step 1

Input pattern serial number value in the box, click "Add" and it will display "Start Rec" and "Stop Rec".

Step 2

Click "Start Rec" to implement a series of operations such as zoom, focus, iris, direction and so on.

Step 3

Click “Stop Rec” to complete the setting of a pattern path.

Step 4

Click “Start” and it will start pattern according to the pattern path which has been set; click “Stop” and the pattern ends.

3.5 Assistant

Assistant interface is shown in Figure 3-8.

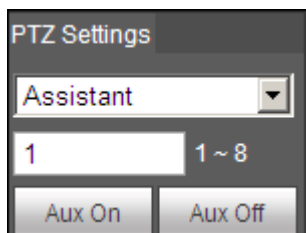

Figure 3-8

Steps to assistant are:

Step 1. In assistant box input assistant value.

Step 2. Click on Aux On to turn on aux function.

Click on Aux off to turn off aux function.

3.6 Light/ Wiper

Light wiper interface is shown in Figure 3-9.

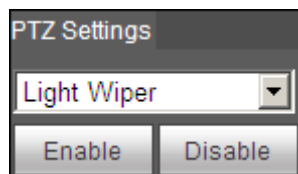

Figure 3-9

Steps to light wiper are:

- Click on Enable to enable light wiper function.
- Click on Disable to disable light wiper function.

4 Playback

Web client playback supports video playback and picture playback.

Note:

Before playback, user shall set storage management as in Ch. 5.4.

4.1 Playback

The playback interface is shown as in Figure 4-.

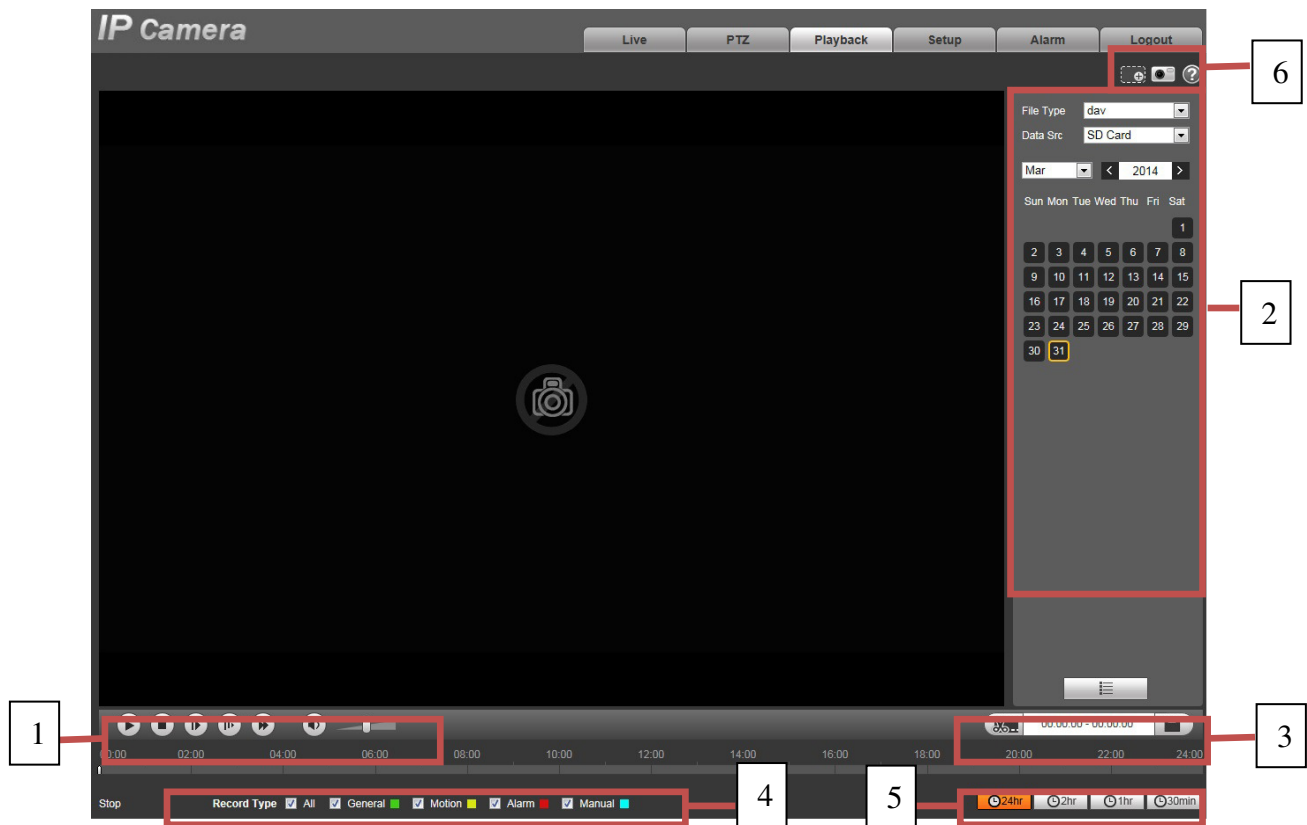

Figure 4-1

There are four sections:

- Section 1: Function of play
- Section 2: Playback file
- Section 3: Play time cut
- Section 4: Record type
- Section 5: Progress bar
- Section 6: Assistant function

4.1.1 Function of Play

The function of play is shown as in Figure 4-2 and Figure 4-3.

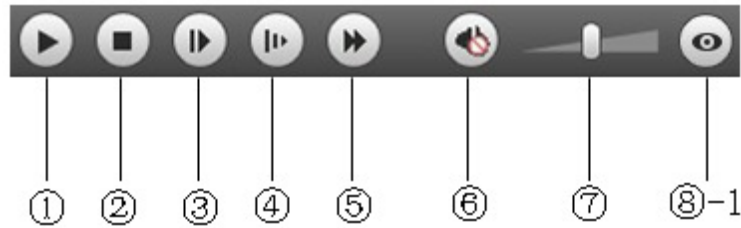

Figure 4-2

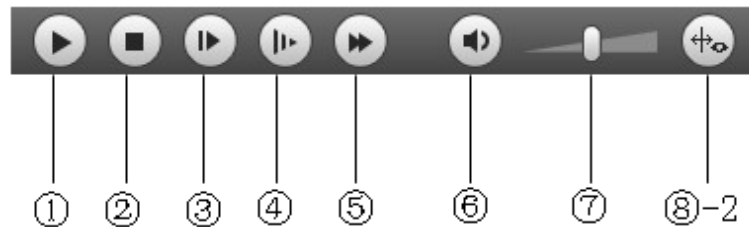

Figure 4-3

Parameter	Function
① Play	When you see this button, it means pause or not played record. Click on this button, switch to normal play status.
② Stop	Click this button to stop playing.
③ Play frame by	Click on this button to go to next frame. Note: You shall pause record when you use this function.
④ Slow	Click on this button to play slowly.
⑤ Quick	Click on this button to play quickly.
⑥ Silent	When this button displays, it means audio is silent. Click on this button to switch back to normal.
⑦ Volume	Click on left mouse to adjust volume.
⑧ -1 Fisheye	Click this button and fisheye device can adjust display mode according to different installation mode during the process of playback.
⑧ -2 Rule Info	Click the button and it will playback and display intelligent rules and object detection box if the video is equipped with intelligent rule info after the function is enabled, it is off by default.

4.1.2 Playback File

In calendar, blue date represents data currently has video record or snapshot. See Figure 4-4.

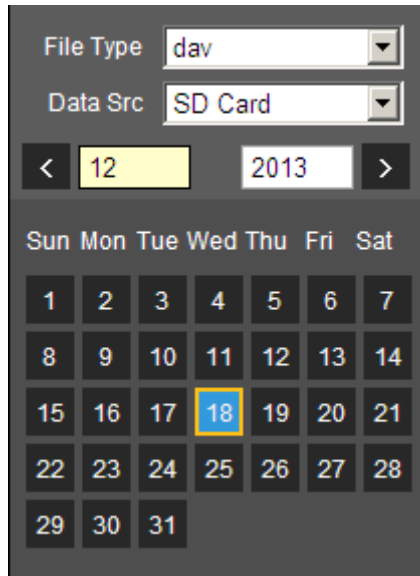

Figure 4-4

Parameter	Function
File Type	<ul style="list-style-type: none"> • Select “dav”, as video playback. • Select “jpg” as picture playback.
Data Source	Default is SD card.

Step 1. Click on data in blue, time axis displays record file progress bar in color. While, green represents normal record, yellow represents motion detect record, red represents alarm record, and blue represents manual record.

Step 2. Click on certain time on progress bar, playback starts from this time. See Figure 4-5.

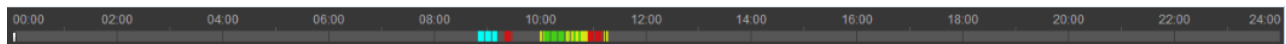

Figure 4-5

Step 3. Click on file list , select date file will be displayed in list.

Step 4. Double click on file in list, playback this file and display file size, start time and end time. See Figure 4-6.

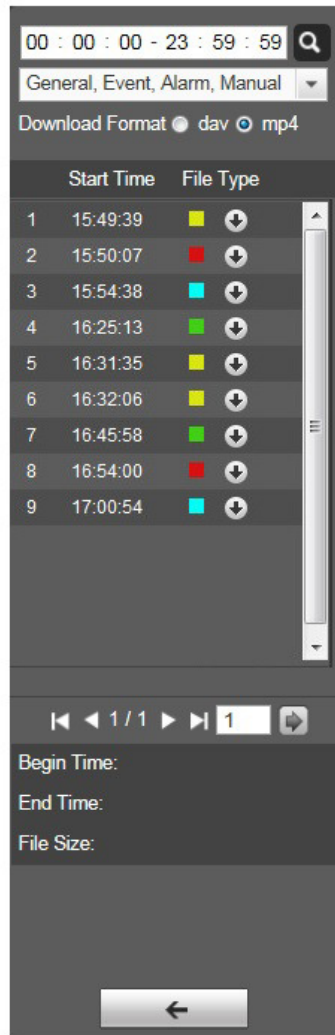





Figure 4-6

Parameter	Function
 Search	It means records within searched start time and end time on the date.
Record Format	There are two formats: dav, mp4.
 Download	<ul style="list-style-type: none"> ● Click the download button and download file to path in Ch. 5.1.2.5. ● System does not support download and playback at the same time.



Parameter	Function
 Back	Click on back button to go to calendar interface.

4.1.3 Playback Cut



Note:

Playback cut function will automatically pause playing record as playback cut and playback cannot be at the same time.

Step 1. Click on start time to cut on time axis. This time must be within progress bar range.

Step 2. Move mouse to cut icon . You will be asked to select start time. Click on cur icon  as finish cutting.

Step 3. Click on playback cut end time on time axis. This time must be within progress bar range.

Step 4. Move mouse to cut icon  you will be asked to select end time. Click on cut icon  as finish cutting.

Step 5. Click on Save button to save file cut to path in Ch 5.1.2.5. See Figure 4-7.

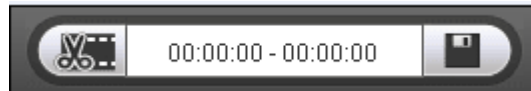

Figure 4-7

4.1.4 Record Type

After checking record file type, only selected file will be displayed in progress bar and file list. Users can also select the record type to be displayed via the dropdown box which is above the file list. See Figure 4-8.







Figure 4-8

4.1.5 Progress Bar



Figure 4-9



Parameter	Function
 24 hours	Click on it, means video in past 24 hours.
 2 hours	Click on it, means video in past 2 hours.
 1 hour	Click on it, means video in past 1 hour.
 30 min	Click on it, means video in past 30 min.

4.1.6 Assistant Function

Video playback assistant function is shown in Figure 4-10.



Figure 4-10

Parameter	Function
 Digital Zoom	<ul style="list-style-type: none"> Click on it, video in playback status if is in original size, user can zoom in any area, If it is not in its original size, right click mouse to restore its original size. Click on this button, you can scroll to zoom in.
 Snapshot	Click on this button, you can snapshot video under playback status. Snapshot will be saved to path in Ch. 5.1.2.5.

4.2 Picture Playback

Web client picture playback interface has the following three functions:

Parameter	Function
1	Play function bar
2	Playback file bar
3	Snapshot type bar

See Figure 4-11.

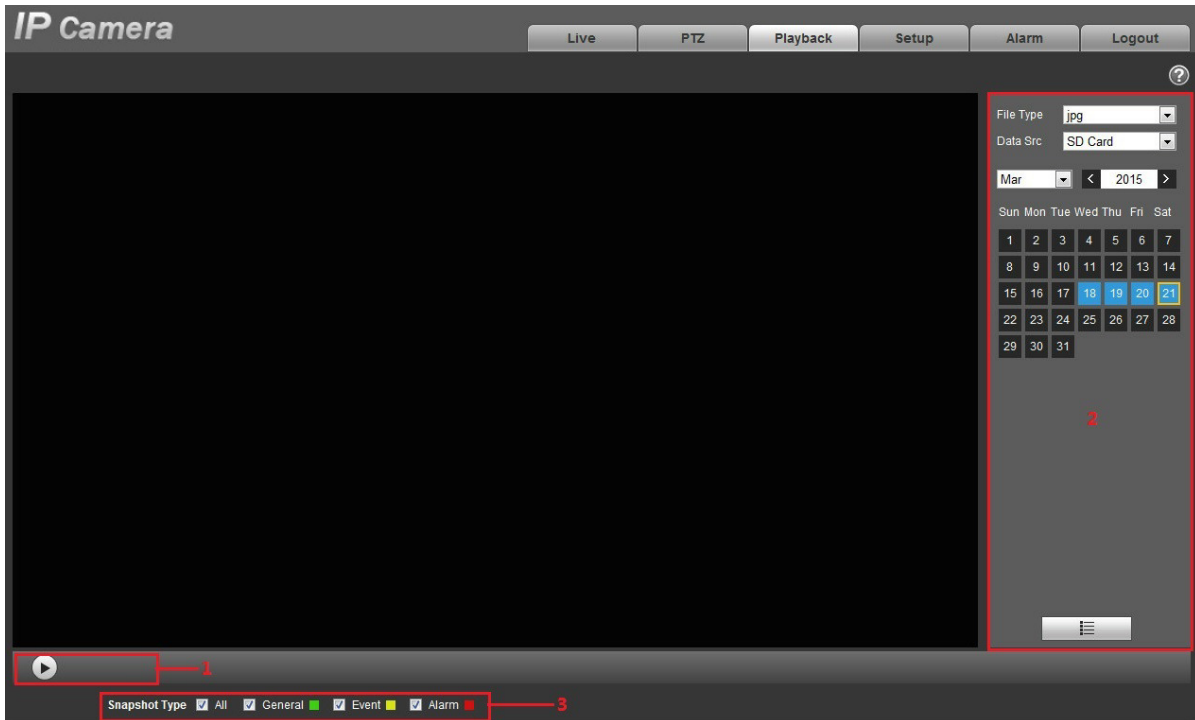



Figure 4-11

4.2.1 Play



Figure 4-12

Default icon is  and it means pause or not played picture. Click on play button to switch to normal play status. Icon become  Click on it to pause.

4.2.2 Playback File

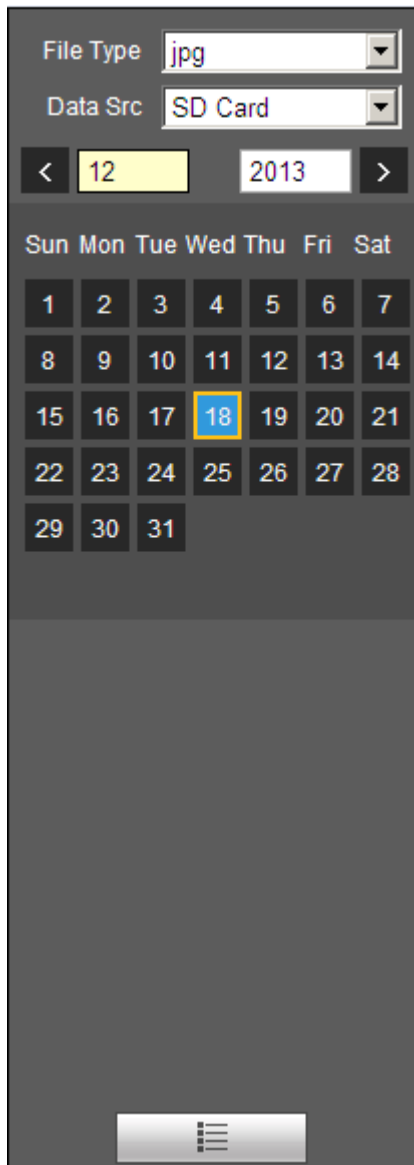





Figure 4-13

Step 1. Click on file list , select snapshot file of the date.

Step 2. Double click on file in list, to play this snapshot.

Parameter	Function
 Search	It means all snapshot files within the start time and end time of selected date.

Parameter	Function
 Download	Click the download button to open snapshot file or directly download to local according to the browser types.
 Back	Click on back button to return to calendar interface and re-select time.

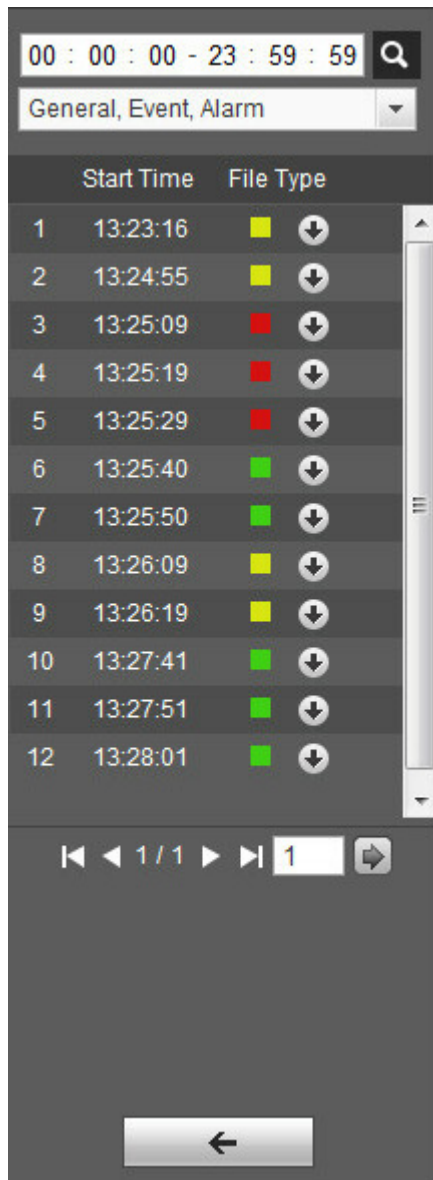

Figure 4-14

4.2.3 Snapshot Type

After checking snapshot file type, in file list only display file of selected type. Users can also select the snapshot type to be displayed via the dropdown box above the file list. See Figure 4-.

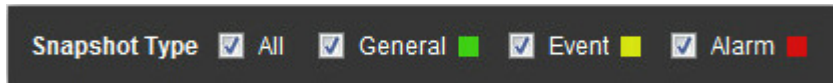

Figure 4-15

5 Setup

Web client setup support camera, network, time, storage, system and system info view.

5.1 Camera

The camera setting includes conditions, profile management, zoom and focus.

5.1.1 Conditions

Note:

The camera parameter may be different according to different models, please refer to the actual product for more details.

5.1.1.1 Picture

Note:

The device which supports true WDR fails to support long exposure when true WDR is enabled.

Step 1

Select “Setup > Camera > Conditions > Picture” and the system will display the “Picture” image which is shown in Figure 5-1.

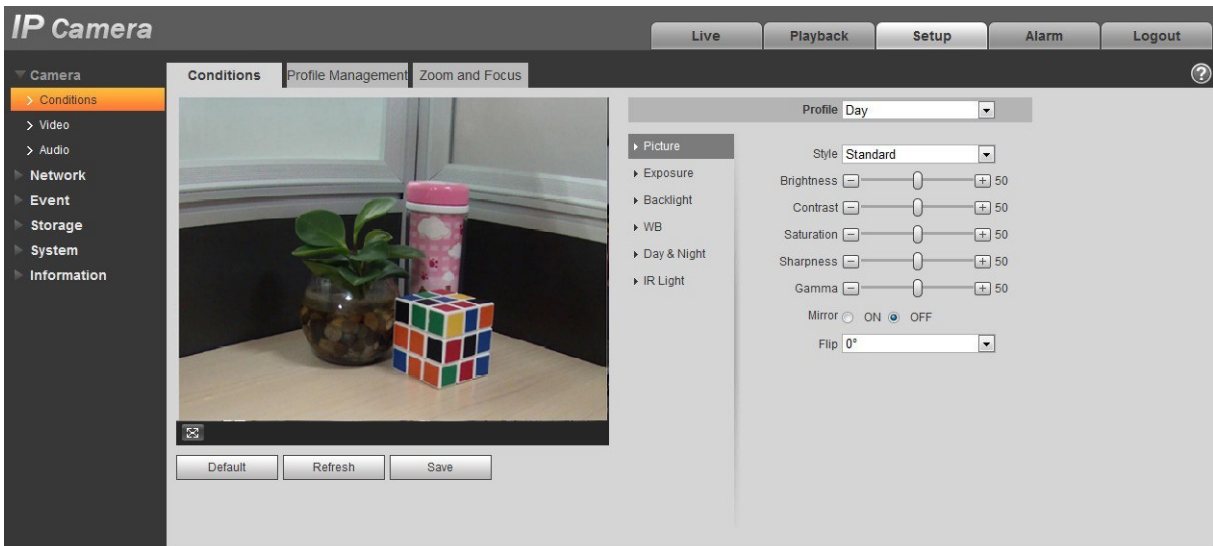

Figure 5-1

Step 2

Set picture parameters; please refer to the following sheet for more details about parameter setting.

Parameter	Note
Style	It is to set the picture style, which includes standard, soft and vivid.

Parameter	Note
Brightness	It is to adjust the image overall brightness via linear adjustment mode. The larger the number is, the brighter the picture is, and on the contrary it is opposite. The picture get blurry easily when the value is set too big.
Contrast	It is to adjust the picture contrast. The bigger the value is, the bigger the bright contrast becomes, and on the contrary it is smaller. The dark area becomes darker and the bright area becomes overexposed easily when the value is set too big. The picture becomes blurry when the value is set too small.
Saturation	It is to adjust the color darkness and lightness. The color becomes darker when the value is bigger; on the contrary it becomes lighter. The value causes no influence to the overall brightness of the image.
Sharpness	It is to adjust the sharpness level of the picture edge. The bigger the sharpness value is, the more obvious the image edge becomes, the image is likely to generate noise more easily when the value is set too big.
Gamma	It is to change image brightness and improve the dynamic display range of the image via nonlinear adjustment mode. The bigger the value is, the brighter the picture becomes, and on the contrary it is opposite.
Mirror	After mirror is enabled, the monitoring image will be displayed invertedly.
Flip	It is to change the display direction of the monitoring image. It includes following options: <ul style="list-style-type: none"> ● Normal: The monitoring picture is normally displayed. ● Flip mode 1: The monitoring picture is displayed with clockwise rotation 90° ● Flip mode 2: The monitoring picture is displayed with anticlockwise rotation 90° ● 180°: The monitoring picture is displayed upside down. Note: Please set the video resolution as 1080P or lower when applying flip mode for some devices.
EIS	It can realize electronic anti-flicker function via comparison algorithm of image difference, which can effectively solve the problem of image jittering during application and it can make the image clearer.

Step 3

Click “Save” and complete the image parameter config of the camera.

5.1.1.2 Exposure

Step 1

Select “Setup > Camera > Conditions > Exposure”. The system will display the “Exposure” interface which is shown in Figure 5-2.

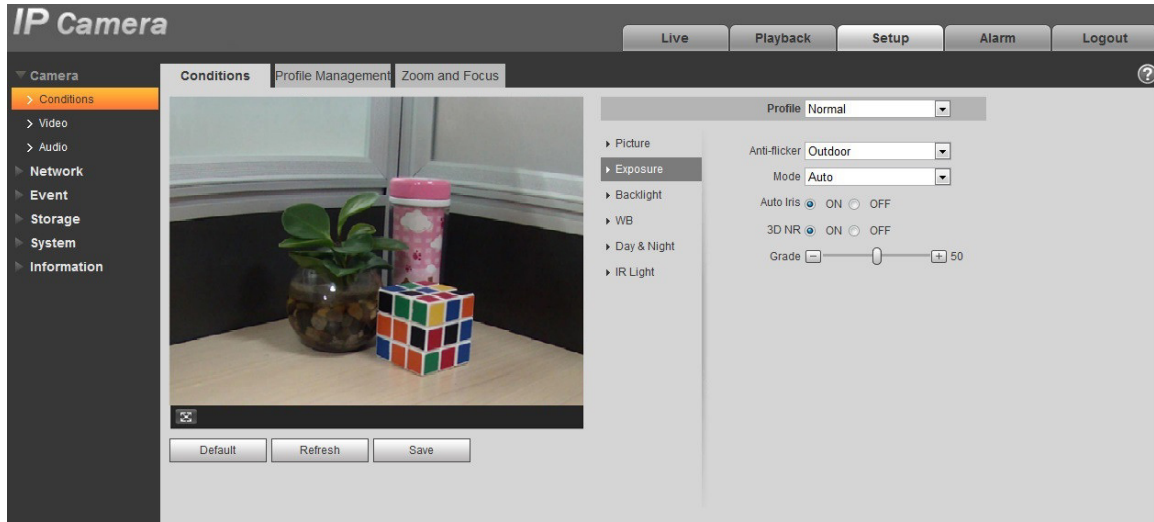

Figure 5-2

Step 2

It is to set the exposure parameter, please refer to the following sheet for more details.

Parameter	Note
Anti-flicker	<ul style="list-style-type: none">● Outdoor: You can switch to exposure mode when it is in outdoor mode, it can realize the result in the corresponding exposure mode.● 50Hz: When the current is 50Hz, system can auto adjust the exposure according to the environment brightness in case there is any stripe.● 60Hz: When the current is 60Hz, system can auto adjust the exposure according to the environment brightness in case there is any stripe.

Parameter	Note
Mode	<p>It is the camera exposure mode.</p> <p>Note:</p> <ul style="list-style-type: none"> ● When “Anti-flicker” is “Outdoor”, the “exposure mode” can be set as “gain priority” or “shutter priority” mode. ● Different devices have different exposure modes; please refer to the actual interface. <p>It includes the following options:</p> <ul style="list-style-type: none"> ● Auto: It can auto adjust the image brightness according to the environment. ● Gain priority: The device can auto adjust according to the gain range which is set by priority during normal exposure range according to the different scene brightness. The device will auto adjust shutter value if the image brightness fails to reach the effect and the gain value has reached to upper limit or lower limit, which is to make the image reach the best brightness. ● Shutter priority: The device can auto adjust according to the shutter range which is set by priority during normal exposure range according to the different scene brightness. The device will auto adjust shutter value if the image brightness fails to reach the effect and the shutter value has reached to upper limit or lower limit, which is to make the image reach the best brightness. ● Iris priority: Iris value is fixed, the device can auto adjust the shutter value if the image brightness fails to reach effect and the shutter value has reached the upper limit or lower limit, the device can auto adjust the gain value to make the image reach the best brightness. ● Manual: It is to manually set gain value and shutter value, adjust the the displayed brightness of the image.
Auto Iris	<p>It can set the parameter when the camera installs auto iris.</p> <ul style="list-style-type: none"> ● The lens iris can auto adjust the size according to the environment after auto iris is enabled, then the image brightness will change accordingly. ● The iris value reaches the max when disabling auto iris, the lens iris will not change according to the environment brightness.
3D NR	<p>It is to process the image with multiframe (at least two frames), it can realize noise reduction of the image by using the interframe information between the previous and latter frame.</p>
Grade	<p>It can set the parameter when “3D NR” is enabled.</p> <p>The bigger the grade is, the better NR effect it can realize.</p>

Step 3

Click “Save” to complete the parameter config of camera exposure.

5.1.1.3 Backlight

Backlight mode can be divided into BLC, WDR and HLS.

BLC: it can avoid cucoloris phenomenon of the darker area in the backlight environment.

WDR: It can suppress the overbright area and compensate darker area by enabling WDR, which can make the overall image clear.

HLC: It is to weaken the high light, which can be applied in the areas such as toll gate, entrance and exit of the parking lot and etc. As for extreme light, it can snapshot the human face in the dark environment and it can realize better effect for the details of the plate number.

Step 1

Select “Setup > Camera > Condition > Backlight”, the system will display the interface of “Backlight” which is shown in Figure 5-3.

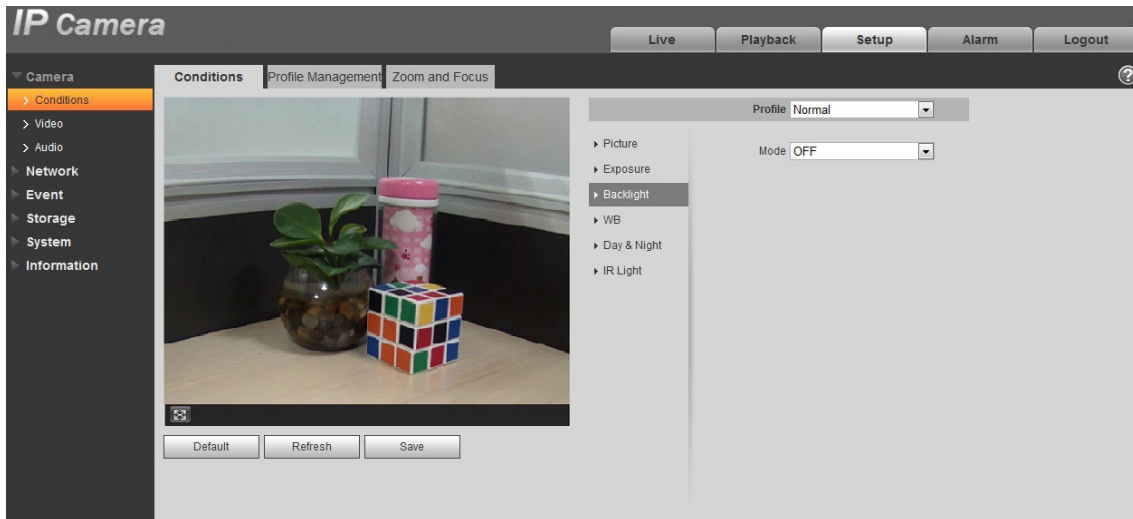

Figure 5-3

Step 2

Set the backlight parameter.

- When the “Mode” is set as “Scene Self-adaptation”, the system will auto adjust the image brightness according to the environmental brightness, which is to make the object display clearly in the scene.
- When the “Mode” is set as “BLC”, it can select default mode or customized mode.
 - ◆ When selecting “Default” mode, the system can realize auto exposure according to the environment, which is to make the image in the darkest area clear to be seen.

- ◆ When selecting “Customized” mode, the system can realize exposure upon the selected area after it set customized area, which is to make the image of the selected area reach appropriate brightness.
- When the “Mode” is set as “WDR”, it will lower the brightness of the area with high brightness and enhance the brightness of the area with low brightness, which is to make the objects in both high brightness and low brightness area display clearly.

Note:

There may be video loss of a few seconds when the camera is switched from non WDR mode to WDR mode.

- When the “Mode” is set as “HLC”, the system will constrain the brightness of the area with high brightness and decrease the size of the halo area, which is to lower the brightness of the whole image.

Step 3

Click “Save” to complete the config of the backlight mode.

5.1.1.4 WB

WB is used to restore the white object in the scene by the camera, after WB mode is set, it can make the white object look white in different environments.

Step 1

Select “Setup > Camera > Conditions > WB”, the system will display the interface of “WB”, which is shown in Figure 5-4.

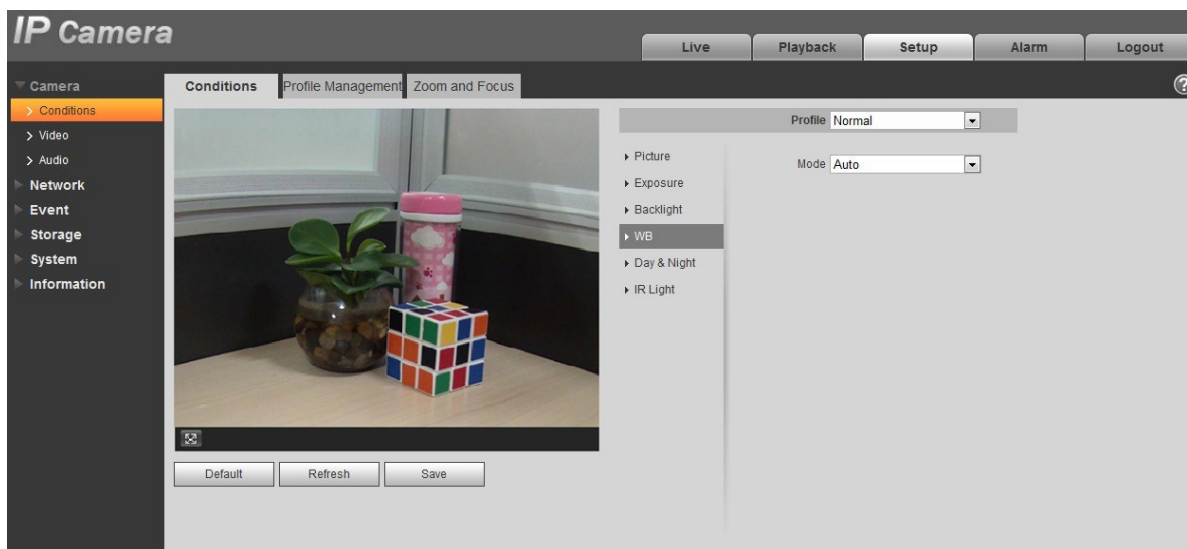

Figure 5-4

Step 2

Set WB mode.

- When the “Mode” is set as “Auto”, the system can auto compensate white balance upon different color temperatures, which is to make the image color normal.
- When the “Mode” is set as “Natural”, the system can auto compensate white balance to the scene without artificial light, which is to make the image color normal.
- When the “Mode” is set as “Street Lamp”, the system can auto compensate white balance to the outdoor scene at night, which is to make the image color normal.
- When the “Mode” is set as “Outdoor”, the system can auto compensate white balance to the most outdoor scenes with natural light and artificial light, which is to make the image color normal.
- When the “Mode” is set as “Manual”, it can manually set the value of red gain and blue gain; the system can compensate the different color temperatures in the environment according to the settings.
- When the “Mode” is set as “Regional Custom”, it is to set customized area, the system can compensate white balance to different color temperature of the images in the area, which is to make the image color normal.

Step 3

Click “Save” to complete the config of WB mode.

5.1.1.5 Day & Night

It is to set the switch between color mode and black & white mode.

Step 1

Select “Setup > Camera > Conditions > Day & Night” and the system will display the interface of “Day & Night”, which is shown in Figure 5-5.

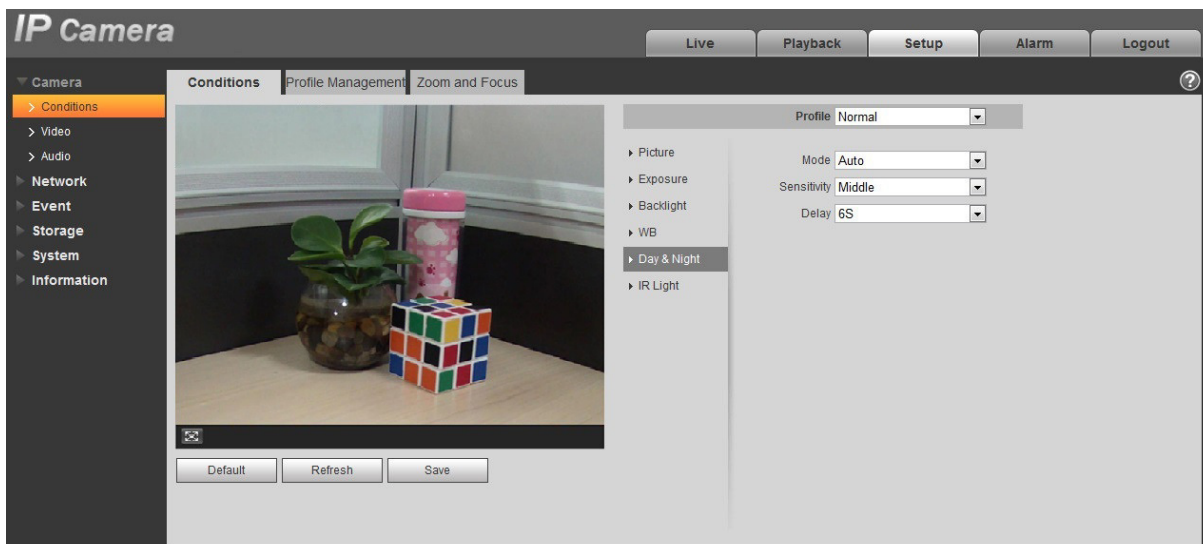

Figure 5-5

Step 2

Set day & night parameter; please refer to the following sheet for more details.

Parameter	Note
Mode	<p>It is to set the camera image displayed as color or black & white mode.</p> <p>Note: The setting of “Day/Night Mode” is not affected by the setting of “Profile Management”.</p> <p>It includes the following options:</p> <ul style="list-style-type: none">● Color: The camera image is displayed as color image.● Auto: The camera can auto select color image or black & white image to be displayed according to the environmental brightness.● Black & white: The camera image is displayed as black & white image.
Sensitivity	<p>The parameter can be set when the “Day/Night Mode” is “Auto”.</p> <p>It is to set the sensitivity of the switch between image color display and black & white display.</p>
Delay	<p>The parameter can be set when the “Day/Night Mode” is “Auto”.</p> <p>It is to set the switch delay between image color display and white & black display. The smaller the delay is, the faster of the switch becomes between color display and black & white display.</p>

Step 3

Click “Save” to complete the config of day/night mode.

5.1.1.6 Defog

The image quality will become weak when the device is in the environment with fog or haze, you can enable defog function to adjust the image definition.

Step 1

Select “Setup > Camera > Conditions > Defog” and the system will display the interface of “Defog” which is shown in Figure 5-6.

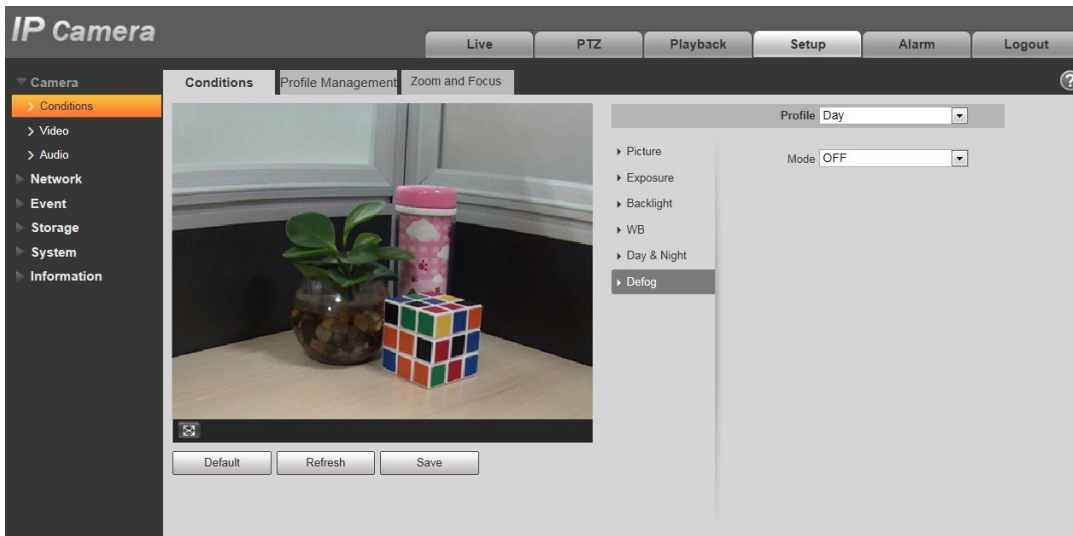

Figure 5-6

Step 2

It is to set defog mode according to the actual scene.

- When the “Mode” is set as “Manual”, it is to manually set intensity and air light mode, the system will adjust the image definition according to the intensity and air light mode which have been set previously. As for air light mode, you can set manual or auto.
- When the “Mode” is set as “Auto”, the system will auto adjust the image definition according to the actual scene.
- When the “Mode” is set as “Off”, then the defog function is disabled.

Step 3

Click “Save” to complete the config of defog mode.

5.1.1.7 IR Light

You can directly set the mode of IR light if the device is equipped with IR light.

Step 1

Select “Setup > Camera > Conditions > IR Light” and the system will display the interface of “IR Light” which is shown in Figure 5-7.

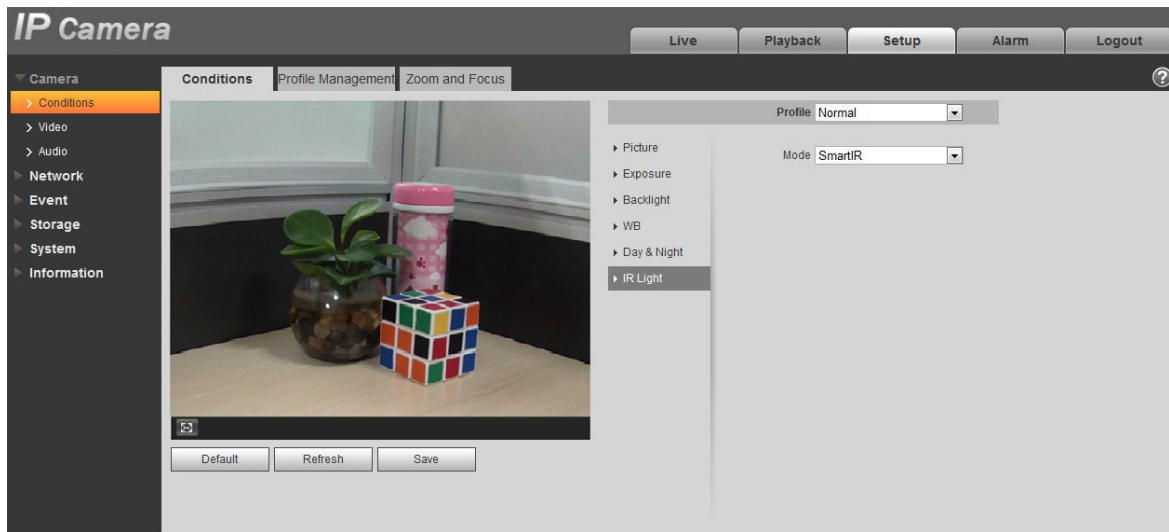

Figure 5-7

Step 2

It is to set IR light mode according to the actual scene.

- When the “Mode” is set as “Manual”, it can manually set the brightness of IR light; the system will realize light compensation to the image according to the IR light intensity.
- When the “Mode” is set as “Smart IR”, the system can adjust the light brightness according to the actual scene.
- When the “Mode” is set as “Zoomprio”, the system can auto adjust the IR light according to the brightness change of the actual scene.
 - ◆ The system will enable near light by priority when the actual scene becomes dark, the system will enable the far light when the near light fails to meet the requirement of scene brightness even if it is adjusted to the brightest.
 - ◆ The system will adjust far light brightness by priority to off and then adjust the brightness of near light when the actual scene becomes bright. The system will always disable far light when the focal length of the lens is adjusted to a certain wide angle, which is to avoid near overexposure. Meanwhile, it can manually set light compensation to slightly adjust the brightness of IR light.
- When the “mode” is set as “Off”, it will not enable the IR light.

Step 3

Click “Save” and complete the config of IR light.

5.1.1.8 Profile Management

Step 1

Select “Setup > Camera > Conditions > Profile Management” and the system will display the interface of “Profile Management”.

Step 2

Set profile management.

- When the “Profile Management” is set as “Normal”, the system will monitor according to the normal config.

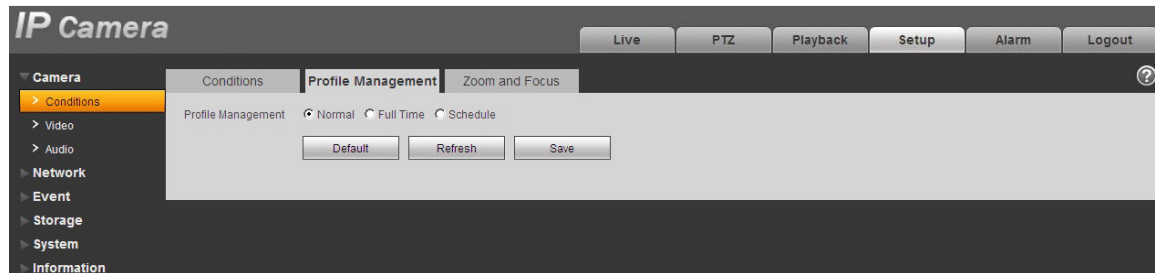

Figure 5-8

- When the “Profile Management” is set as “Full Time”, you can select “Always Enable” in “Day” or “Night”, the system will monitor according to the config of “always enable”.

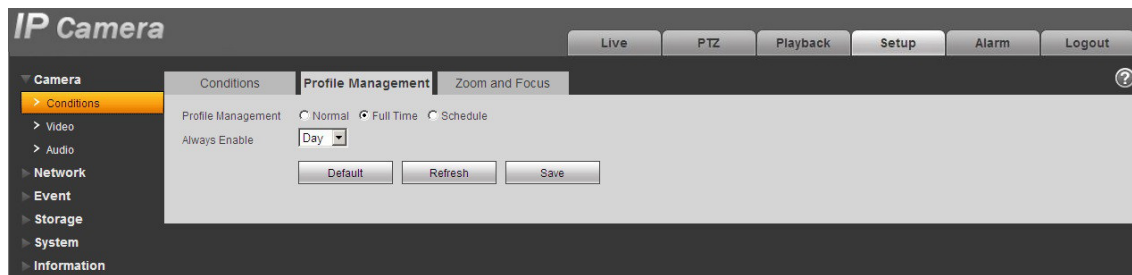

Figure 5-9

- When the “Profile Management” is set as “Schedule”, you can set some period as day and another period as night, for example, if it sets 0:00~12:00 as day, 12:00~24:00 as night, then the system will monitor by adopting corresponding config in different periods.

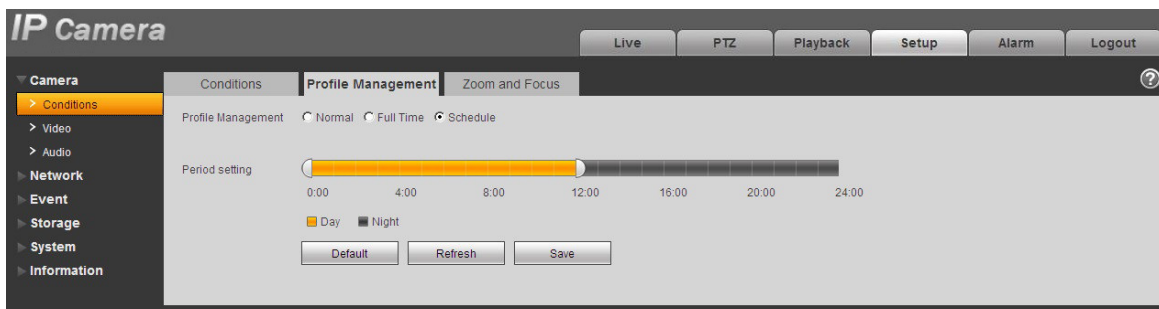

Figure 5-10

Step 3

Click “Save” to complete the settings of profile management.

Note:

Click “Default” to restore the device to default config; click “Refresh” to check the latest config file of the device.

5.1.1.9 Zoom and Focus

Note:

Only motorized vari-focal devices support focus and zoom function.

Step 1

Select “Setup > Camera > Conditions > Zoom and Focus” and the system will display the interface of “Zoom and Focus” which is shown in Figure 5-11.

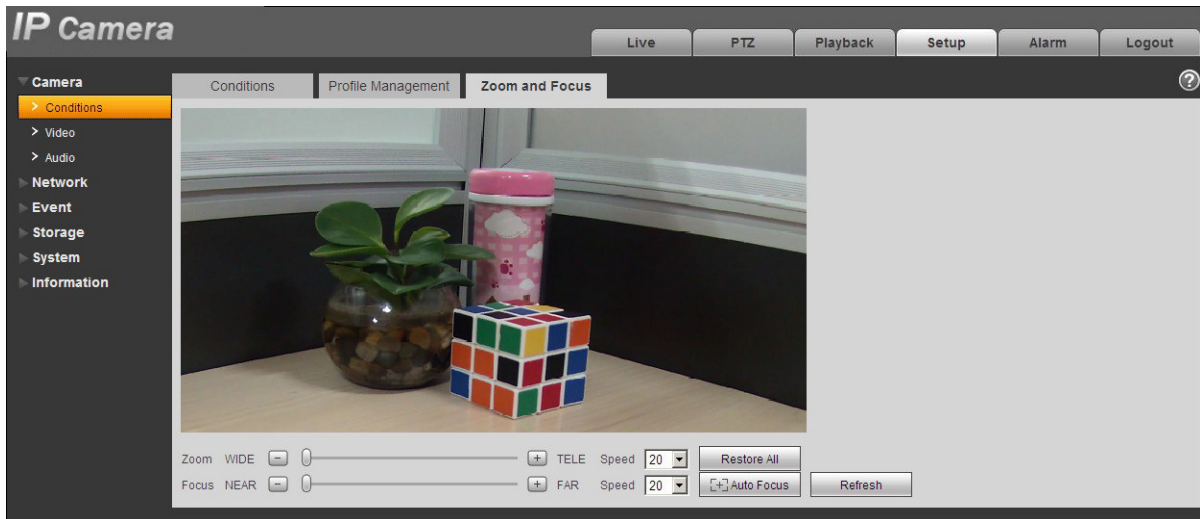

Figure 5-11

Step 2

Adjust the focal length of the lens.

After it is zoomed, set “Speed” and press “+”, “-“or drag the sliding block directly to adjust.

Step 3

Adjust the lens definition.

After it is focused, set “Speed” and press “+”, “-“or drag the sliding block directly to adjust.

Note:

- Speed is used to set the length by pressing “+” and “-“.
- After adjusting the focal length of the lens or click “Auto Focus”, the device will auto adjust the image definition, it is not allowed to implement other lens operation during auto focus.
- After several times of zoom and focus, the image fails to be adjusted clear, click “Restore All” to reset the lens to zero and remove the accumulative error of the lens.
- Click “Refresh” and the device will automatically synchronize the hardware to the location of sliding block of lens zoom and focus.

5.1.2 Video

5.1.2.1 Video

Step 1

Select “Setup > Camera > Video > Video” and the system will display the interface of “Video” which is shown in Figure 5-12 or Figure 5-13.

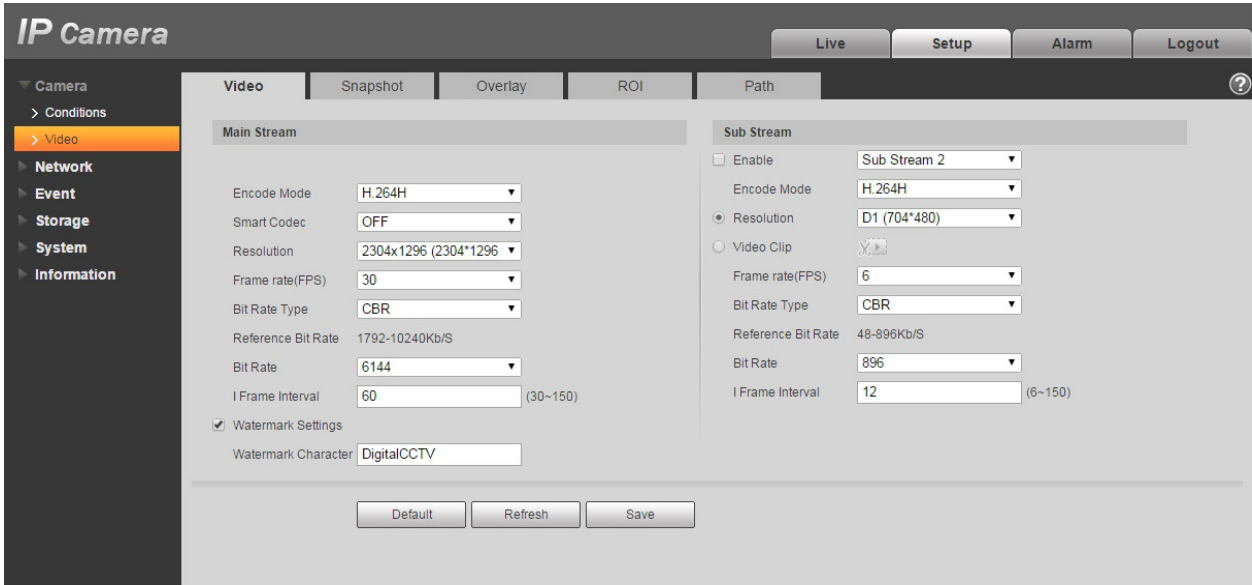

Figure 5-12 (Non fisheye)

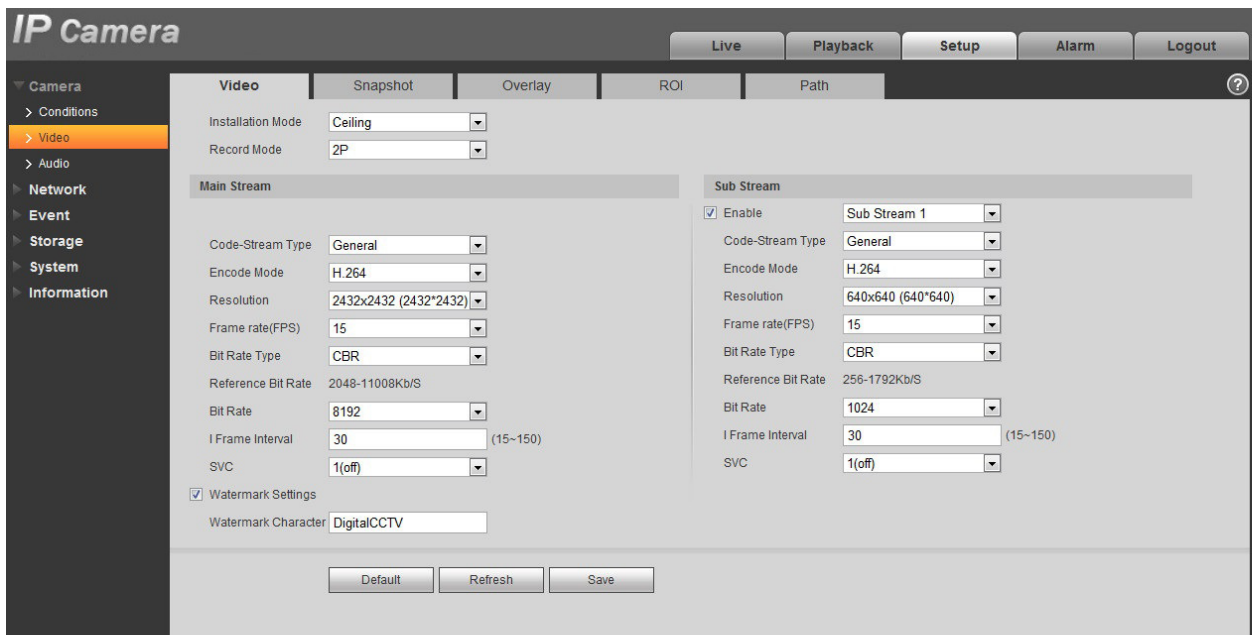

Figure 5-13 (Fisheye)

Step 2

Set video bit stream, please refer to the following sheet for more details about the parameters.

Parameter	Function
Installation Mode	<p>It will display the parameter when the device is fisheye. There are three installation modes for fisheye which are ceiling, wall mount and ground installation, please select installation mode according to the actual installation scene of the fisheye.</p> <p>The system will begin to switch after switching installation mode, it will prompt successfully saved after it is switched successfully.</p> <p>Note: The device end will output the dewarped video stream after configuring installation and record mode, when the device is accessed to third-party platform, it will directly display the dewarped image on the third-party platform.</p>
Record Mode	<p>It will display the parameter when the device is fisheye. The system will begin to switch after record mode is switched, it will prompt saved successfully after it is switched successfully.</p> <p>The record mode will change according to the different installation modes.</p> <ul style="list-style-type: none"> ● 1O: the original picture which is not dewarped. ● 1P: 360°rectangular panorama. ● 2P: The mode can be set when the “Installation Mode” is set as “Ceiling” or “Ground”. It is the 2 related 180°rectangular image, the two subwindows can both form 360°panorama anytime. ● 1O+3R: original image + 3 independent sub images, both the sub image and sub boxes in the original image can support zoom and movement. ● 1R: Original image + independent sub image, the sub boxes of the original image support zoom and movement. ● 4R: original image + 4 independent sub images, both the sub image and sub boxes in the original image support zoom and movement. ● 2R: Original image + 2 independent sub images, the sub boxes of the original image can support zoom and movement, the sub image supports up and down movement, which can change the vertical angle of view. <p>Note: The device end will output dewarped video stream after configuring installation and record mode, when the device is accessed to the third-party platform, it will directly display the dewarped image on the third-party platform.</p>

Parameter	Function
Sub Stream Enable	Select "Enable" to enable sub stream. The device supports enabling sub stream 1 and sub stream 2 at the same time.
Smart Codec	It can enhance image compression performance and reduce storage space by enabling intelligent encoding. Note: After intelligent encoding is enabled, the device will not support third stream, ROI or intelligent event detection, please refer to the actual interface for more details.
Code-Stream Type	ACF means using different fps to record. There are two options: VBR and CBR. Please note you can set video quality in VBR mode. Note: WEB interfaces don't support motion detect and alarm code stream setting.
Encode mode	There are five options: H.264 (main profile standard, H.264H (high profile standard), H.264B (Baseline Profile), H.265 (main profile standard) and MJPEG encode. <ul style="list-style-type: none"> ● The H.264, H.264H both are H264 bit stream. H.264 is the Main Profile encode and you need to enable the sub stream function in your camera and set the resolution as CIF. Then you can monitor via the Blackberry cell phone. ● The H.265 is the main profile encode mode. ● MJPEG: In this encode mode, the video needs to large bit stream to guarantee the video definition. You can use the max bit stream value in the recommend bit to get the better video output effect.
Resolution	There are multiple resolutions. You can select from the dropdown list. For each resolution, the recommended bit stream value is different. Note: When video is under rotating status, you cannot set resolution higher than 1080P (excluding 1080P).
Video Clip	The function is only supported by sub stream 2, please refer to "Video Clip" for more details below the sheet.
Frame Rate (FPS)	PAL: 1~25f/s, 1-50f/s NTSC: 1~30f/s or 1~60f/s. The frame rate may vary due to different resolutions.
Bit Rate Type	There are two options: VBR and CBR. Please note, you can set video quality in VBR mode. Under MJPEG mode, only CBR is available.
Recommended Bit	Recommended bit rate value according to the resolution and frame rate you have set.

Parameter	Function
Bit Rate	<ul style="list-style-type: none"> ● In CBR, the bit rate here is the max value. In dynamic video, system needs to low frame rate or video quality to guarantee the value. ● The value is null in VBR mode. ● Please refer to recommend bit rate for the detailed information.
SVC	Frame rate can be encoded by layer. It is a flexible encoding method. By default, it is 1 as 1 layer. You also can set 2/3/4 layers.
I Frame	<p>Here you can set the P frame amount between two I frames. The value ranges from 1 to 150. Default value is 50.</p> <p>Recommended value is frame rate *2.</p>
Watermark Settings	Select "Watermark Setting" and enable watermark function. After the watermark function is enabled, you can check if the video is tampered via verifying watermark character.
Watermark Character	It is the character of watermark verification, it is DigitalCCTV by default.

- Video Clip

1. Select "Sub Stream 2" in the drop-down box, click "Enable".

2. Enable "Video Clip", click .

The system will display the interface of "Area", which is shown in Figure 5-14.

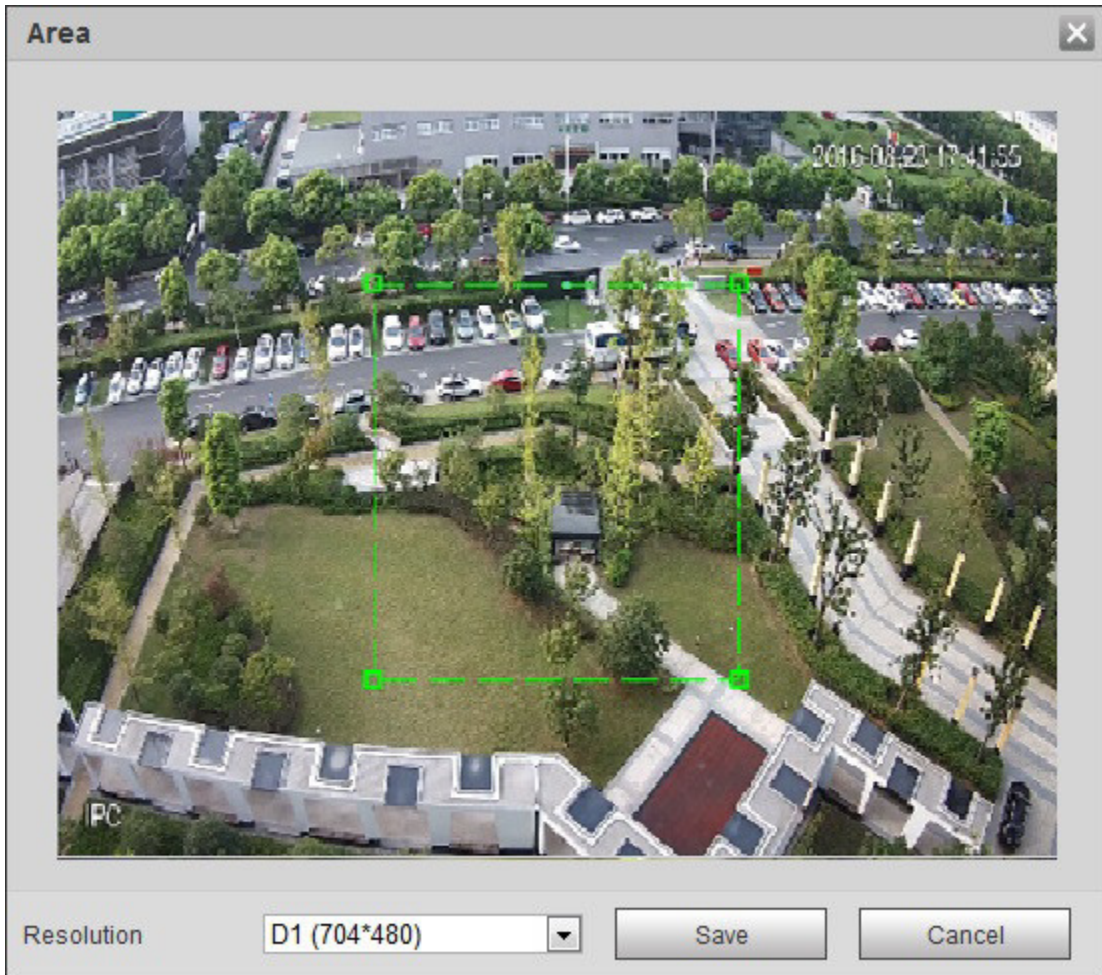

Figure 5-14

3. Select the needed resolution and clip the needed image on the interface, which is shown in Figure 5-15.
4. Click "Save". You can check the clipped video in the preview interface (the sub stream 2 preview interface only displays the clipped area), which is shown in Figure 5-15.

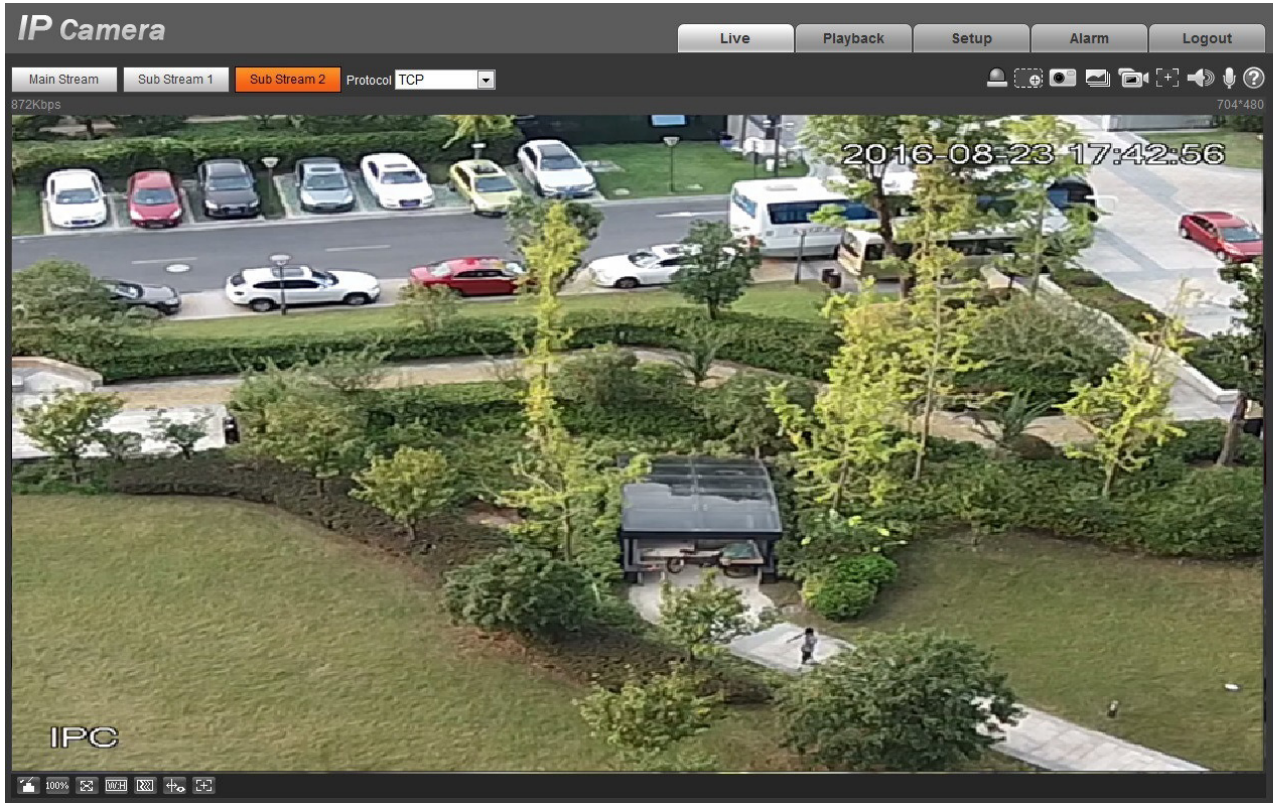

Figure 5-15

Step 3

Click “Save” to complete video stream setup.

5.1.2.2 Snapshot

The snapshot interface is shown as in Figure 5-16.

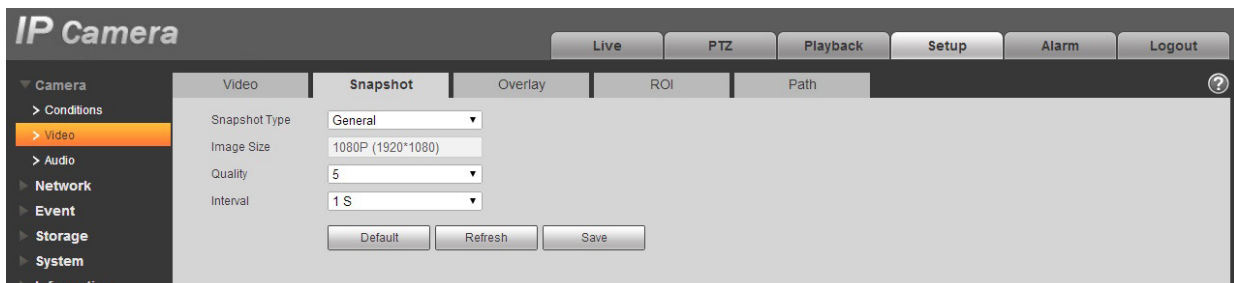

Figure 5-16

Please refer to the following sheet for detailed information.

Parameter	Function
Snapshot type	There are two modes: general (schedule) and Event (activation).
Image size	It is the same as the resolution of main stream.
Quality	It is to set the image quality. There are six levels.
Interval	It is to set snapshot frequency. Optional 1~7s/picture, customized.

5.1.2.3 Video Overlay

The video overlay interface is shown as in Figure 5-17.

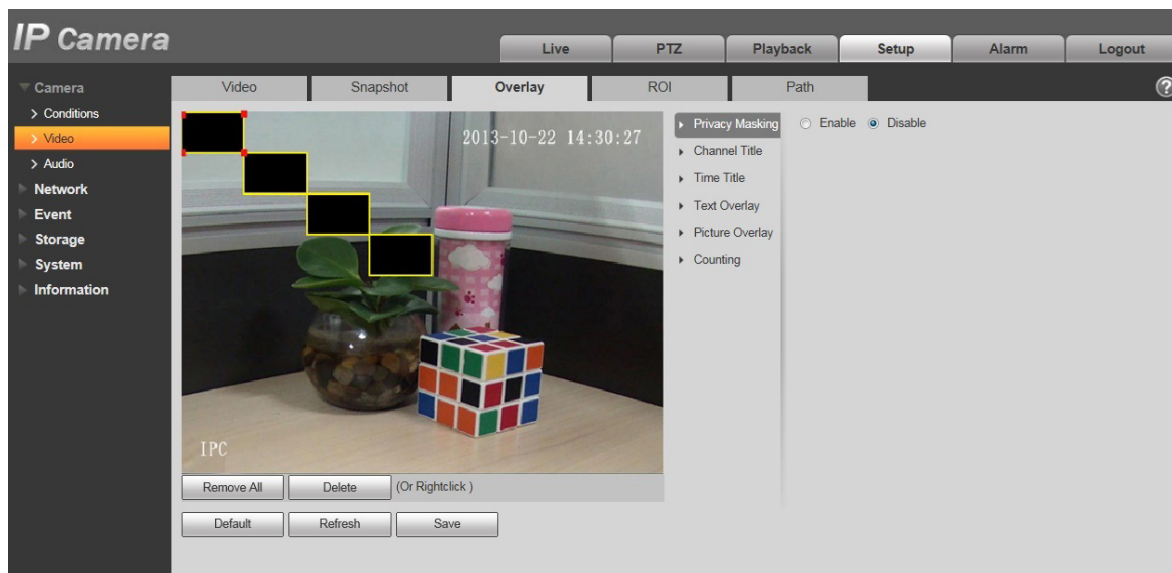

Figure 5-17

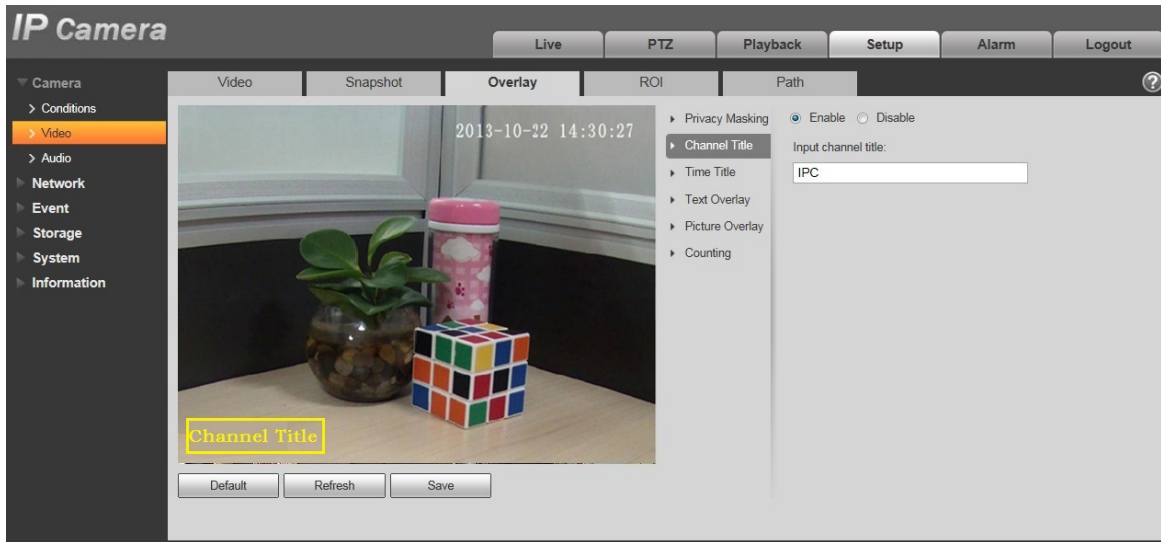

Figure 5-18

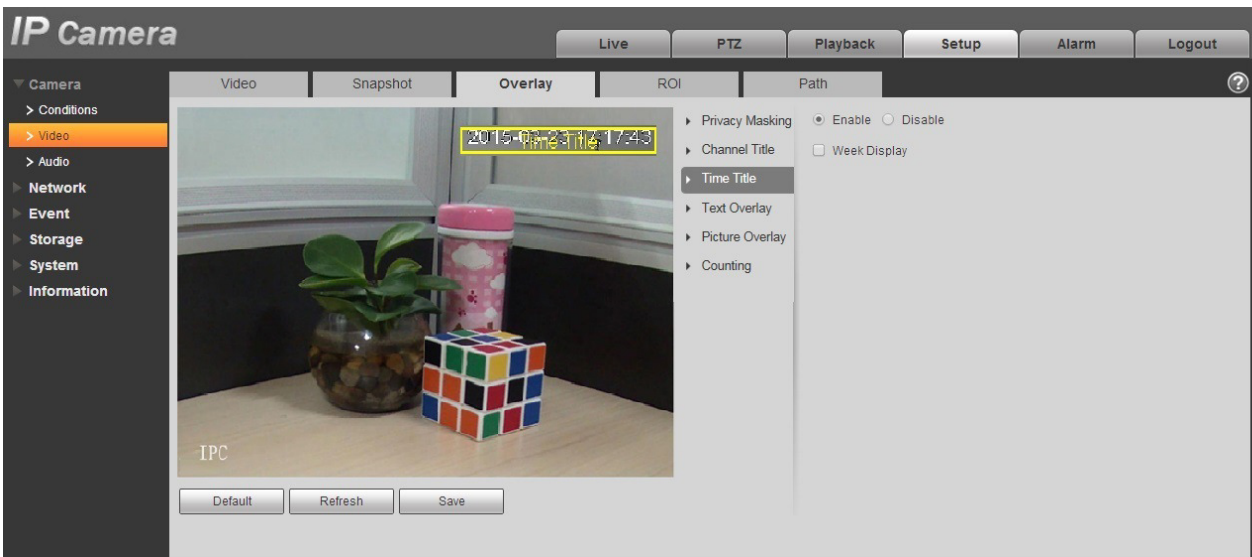

Figure 5-19

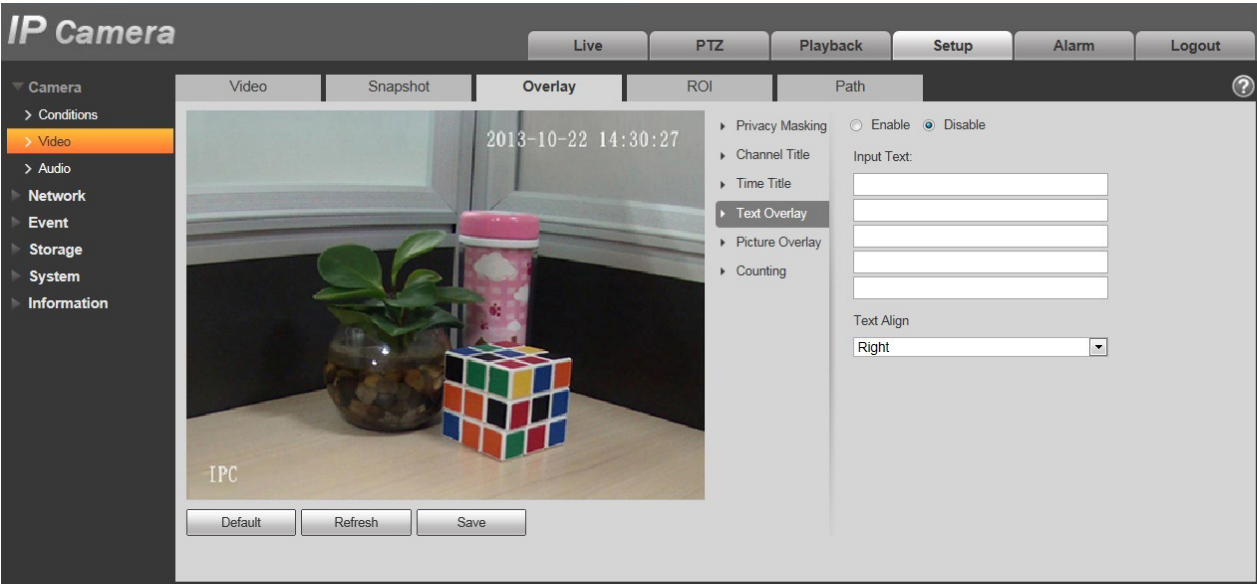

Figure 5-20

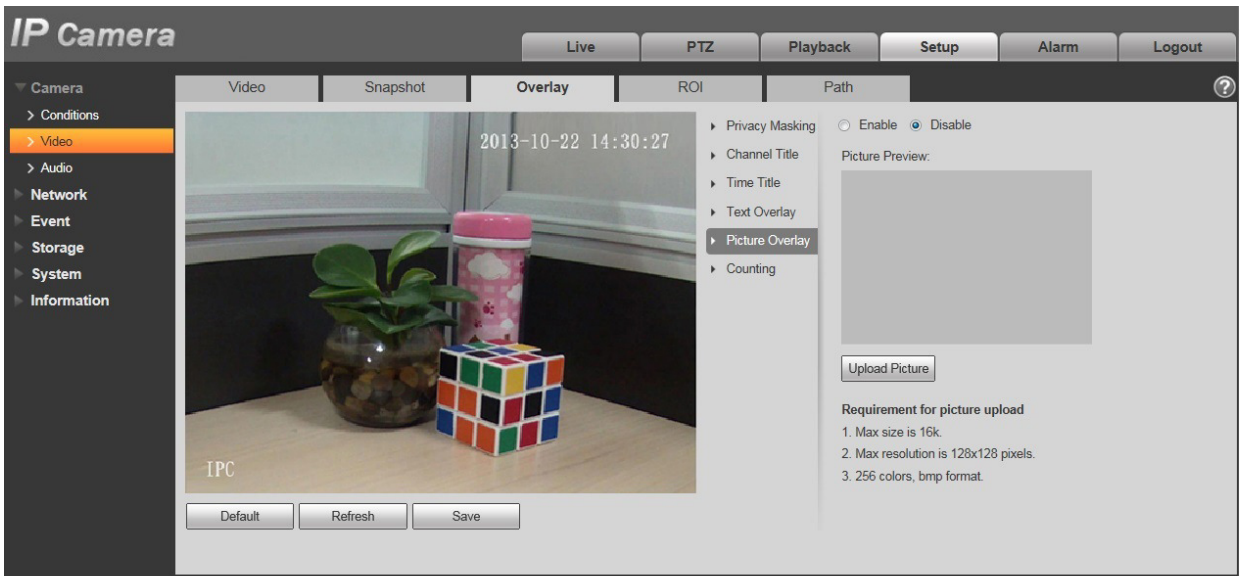

Figure 5-21

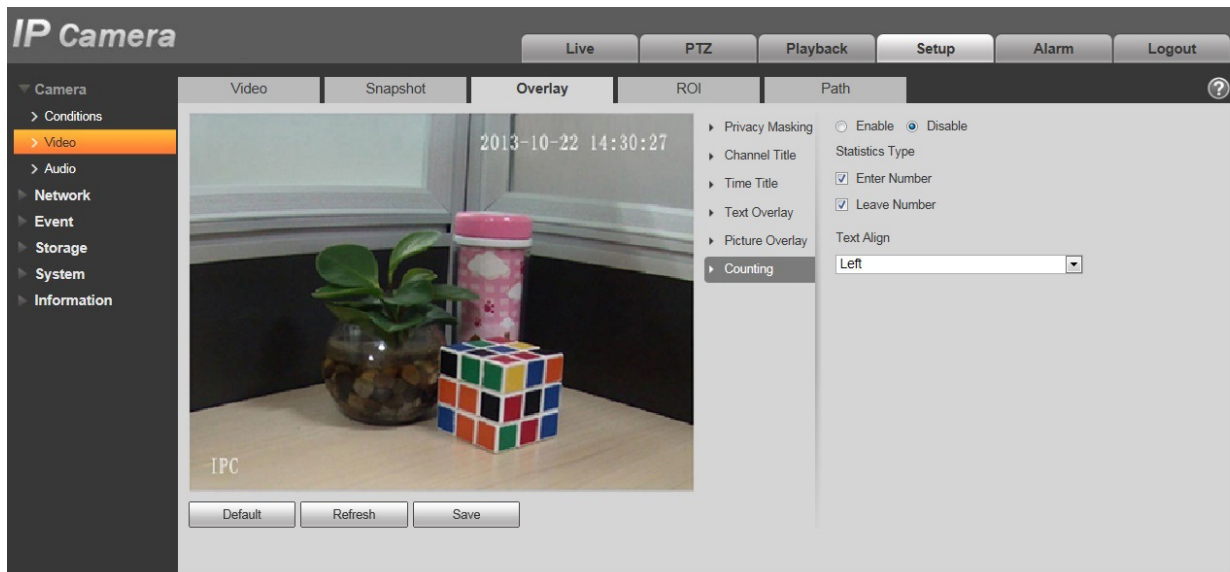

Figure 5-22

Please refer to the following sheet for detailed information.

Parameter	Function
Privacy Masking	<ul style="list-style-type: none"> ● Here you can privacy mask the specified video in the monitor video. ● System max supports 4 privacy mask zones.
Time Title	<ul style="list-style-type: none"> ● You can enable this function so that system overlays time information in video window. ● You can use the mouse to drag the time tile position.
Channel Title	<ul style="list-style-type: none"> ● You can enable this function so that system overlays channel information in video window. ● You can use the mouse to drag the channel tile position.
Text Overlay	<ul style="list-style-type: none"> ● You can enable this function to overlay text in video window. ● You can use the mouse to drag location box to adjust its position. Alignment include align left and align right.
Picture Overlay	<ul style="list-style-type: none"> ● You can enable this function to display overlay picture. Click on disable to turn it off. ● Click on Upload Picture to overlay local picture into monitoring window. You can drag the yellow box to move it. <p>Note: You cannot enable text and picture overlay at the same time.</p>
Counting	<ul style="list-style-type: none"> ● Check “Enable” to display the counting statistics data in the video monitoring window; check “Disable” not to display. ● There are enter number and leave number for statistics type and left align and right align for OSD info.

Refresh	<ul style="list-style-type: none"> ● Set privacy mask, channel title, time title, location, overlay and save the change. You can click on Refresh to see effect.
Default	<ul style="list-style-type: none"> ● Click it to restore default config.
Save	<ul style="list-style-type: none"> ● Click it to complete video settings.

5.1.2.4 ROI

Note: Some series don't support ROI setup function.

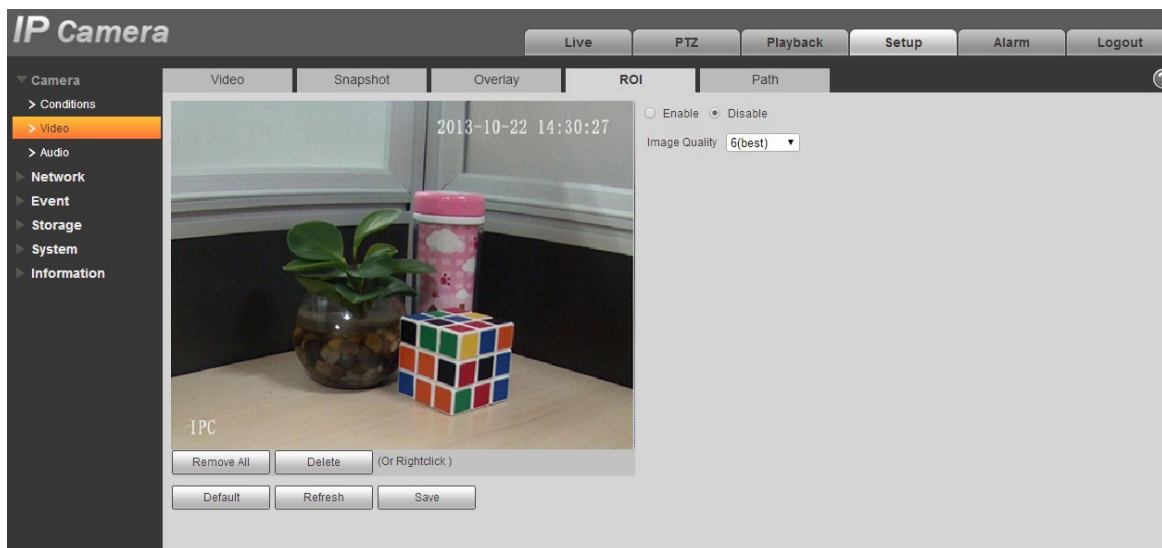

Figure 5-23

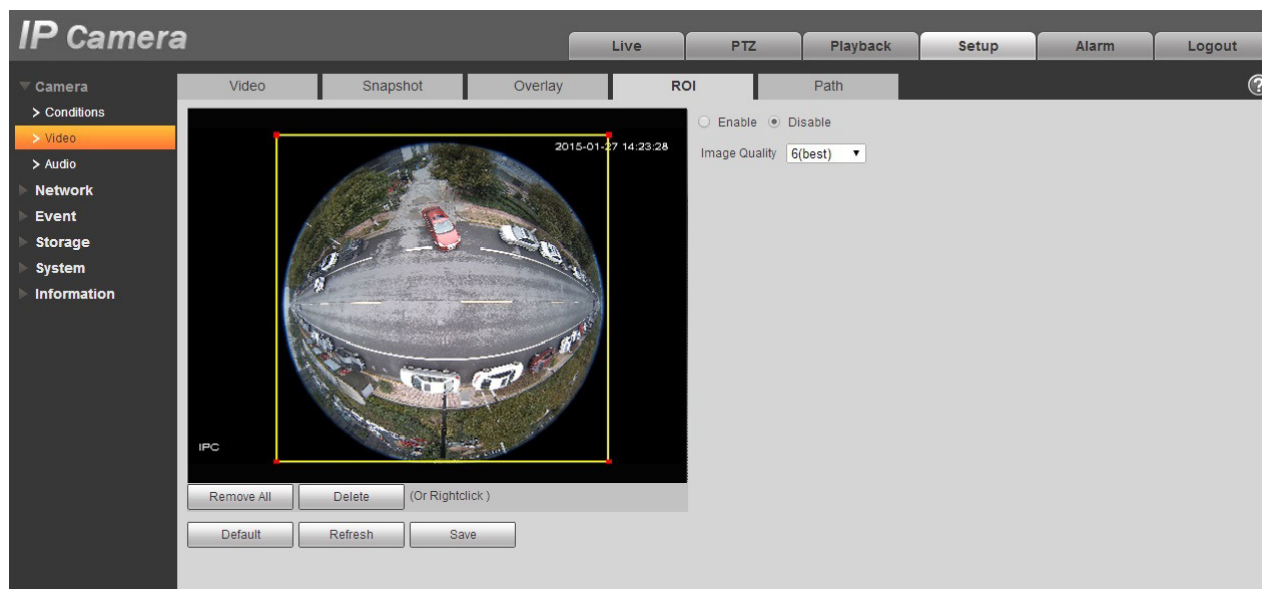

Figure 5-24

Parameters	Note
Enable	Check “Enable”, then it will display the ROI in the video monitoring window; Check “Disable”, then it won’t display.
Image Quality	<ul style="list-style-type: none"> Set the image quality of ROI, ranging from 1~6, default is 6. Note: For fisheye device, it ranges from 1~6 (best), default is 6 (best) <ul style="list-style-type: none"> Able to set area block, max 4 areas.

5.1.2.5 Path

The storage path interface is shown as in Figure 5-25.

Here you can set snap image saved path and the record storage path.

- The default monitor image path is C:\Users\admin\WebDownload\LiveSnapshot.
- The default monitor record path is C:\Users\admin\WebDownload\LiveRecord.
- The default playback snapshot path is C:\Users\admin\WebDownload\PlaybackSnapshot.

The default playback download path is C:\Users\admin\WebDownload\PlaybackRecord.

The default playback cut path is: C:\Users\admin\WebDownload\VideoClips.

Note:

Admin is locally logged in PC account.

Please click the Save button to save current setup.

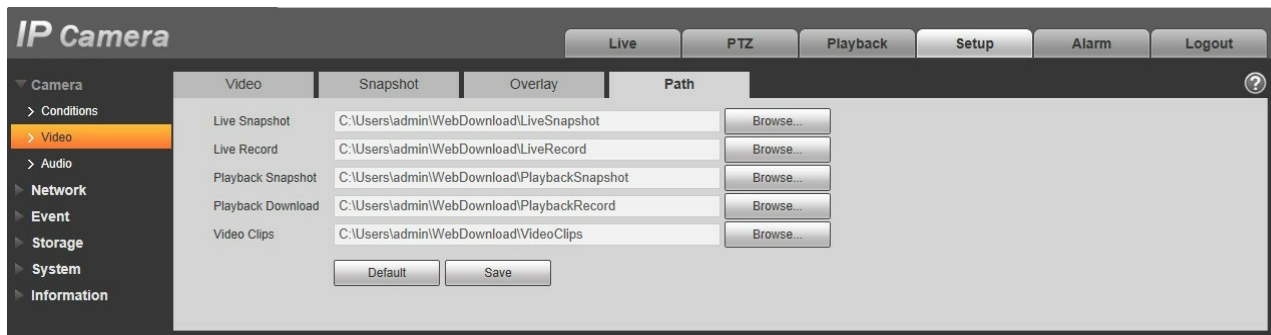

Figure 5-25

5.1.3 Audio

Please note some series devices do not support audio function.

5.1.3.1 Audio

The audio interface is shown as below. See Figure 5-26.

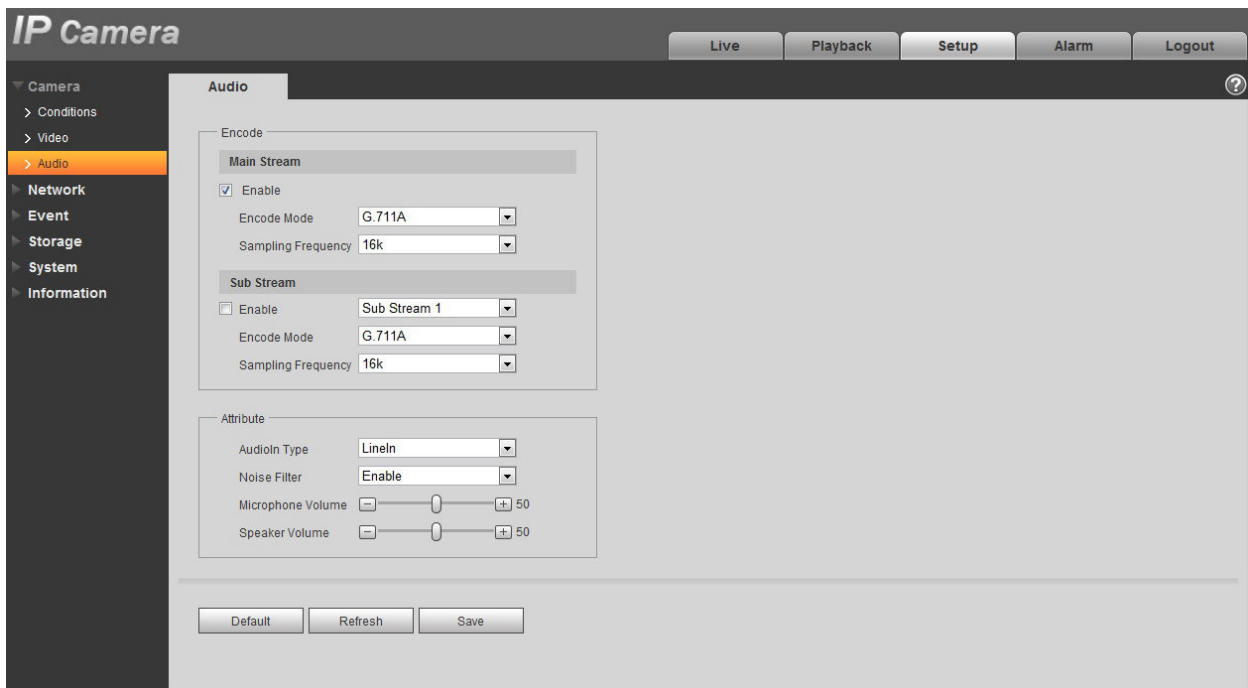

Figure 5-26

Please refer to the following sheet for detailed information.

Parameter	Function
Enable	You can enable audio only when video is enabled. After selecting the “Enable” of main stream or sub stream, the network transmission stream is the audio/video composite stream, otherwise it only includes video image.
Encode mode	The encode mode of the main stream and extra stream include G.711A, G.711Mu, G.726 and ACC. The default mode is G.711A. The setup here is for audio encode mode and the bidirectional talk encode both.
Sampling Frequency	The sampling frequency of audio. It includes the following options: <ul style="list-style-type: none"> ● 8K ● 16K ● 32K ● 48K ● 64K

AudiIn Type	Two modes to select: LineIn, Mic. Device needs to connect external audio input source under LineIn mode, and it doesn't need to connect external audio input source under Mic mode.
Noise Filter	Enable the function and it can filter relevant noise.
Microphone Volume	Adjust microphone volume from 0~100. Note: Supported by some devices.
Speaker Volume	Adjust speaker volume from 0~100. Note: Supported by some devices.

5.1.3.2 Alarm audio

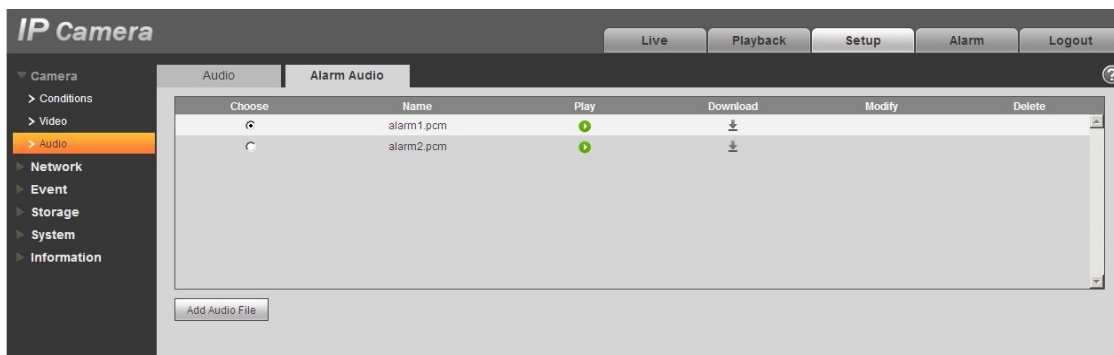

Figure 5-27

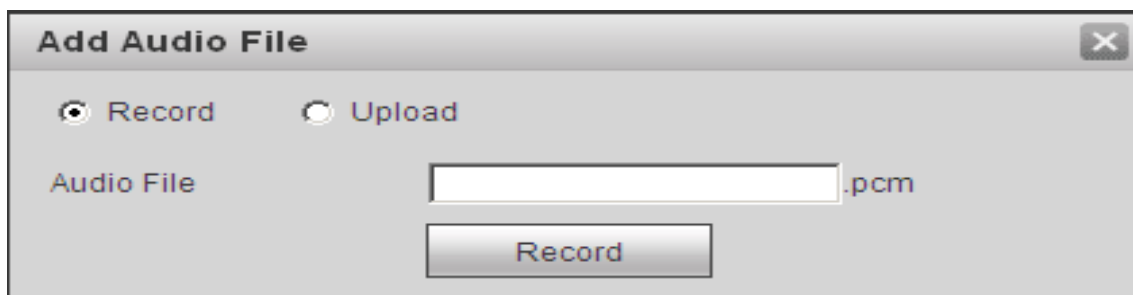



Figure 5-28

Audio management currently supports PCM format to record and PCM, wav two forms to upload, and can select an audio file for the audio alarm linkage.

The way to download the web alarm playback audio file into local is as follows:

Step 1 Use the left mouse button to click the hollow circle  in the “choice” column on the left, and shows , which means effective choice of alarm audio.

Step 2 Use the right mouse button to click , select “save target as” to download.

5.2 Network

5.2.1 TCP/IP

The TCP/IP interface is shown as in Figure 5-29. It supports IPv4 and IPv6. IPv4 supports static IP and DHCP. IPv6 supports static IP only. When users manually modify IP address, WEB will automatically jump to the new IP address.

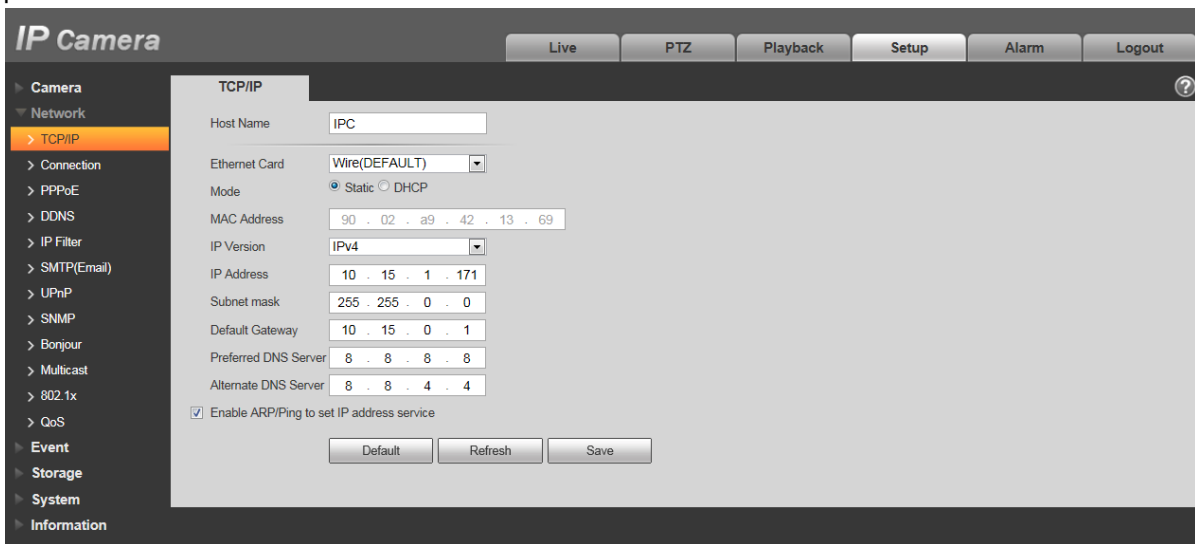

Figure 5-29

Please refer to the following sheet for detailed information.

Parameter	Function
Host Name	It is to set current host device name. It max supports 15 characters.
Ethernet Card	Please select the Ethernet port. Default is wired. Please note you can modify the default Ethernet card if there is more than one card.
Mode	There are two modes: static mode and the DHCP mode. Select DHCP mode, it auto searches IP, and you cannot set IP/subnet mask/gateway. Select static mode, you must manually set IP/subnet mask/gateway.
Mac Address	It is to display hose Mac address.

IP Version	It is to select IP version. IPV4 or IPV6. You can access the IP address of these two versions.
IP Address	Please use the keyboard to input the corresponding number to modify the IP address and then set the corresponding subnet mask and the default gateway.
Preferred DNS	DNS IP address.
Alternate DNS	Alternate DNS IP address.
Enable ARP/Ping set device IP address service.	<p>You can use ARP/Ping command to modify or set the device IP address if you know the device MAC address.</p> <p>Before the operation, please make sure the network camera and the PC in the same LAN. This function is on by default.</p> <p>You can refer to the steps listed below.</p> <p>Step 1: Get an IP address. Set the network camera and the PC in the same LAN.</p> <p>Step 2: Get the physical address from the label of the network camera.</p> <p>Step 3: Go to the Run interface and then input the following commands.</p> <pre>arp -s <IP Address> <MAC> ping -l 480 -t <IP Address></pre> <p>Such as: arp -s 192.168.0.125 11-40-8c-18-10-11 ping -l 480 -t 192.168.0.125</p> <p>Step 4: Reboot the device.</p> <p>Step 5: You can see the setup is OK if you can see there are output information such as "Reply from 192.168.0.125 ..." from the command output lines. Now you can close the command line.</p> <p>Step 6: Open the browse and then input http://<IP address>. Click the Enter button, you can access now.</p>

5.2.1.1 Easy4ip

Click "Enable" to connect the device to network, and then you can connect to the device via mobile client of Easy4ip after "Online" is displayed on the interface (connection mode: add device serial number or scan QR code). See Figure 5-30.



Figure 5-30

5.2.2 Connection

5.2.2.1 Connection

The connection interface is shown as in Figure 5-31.

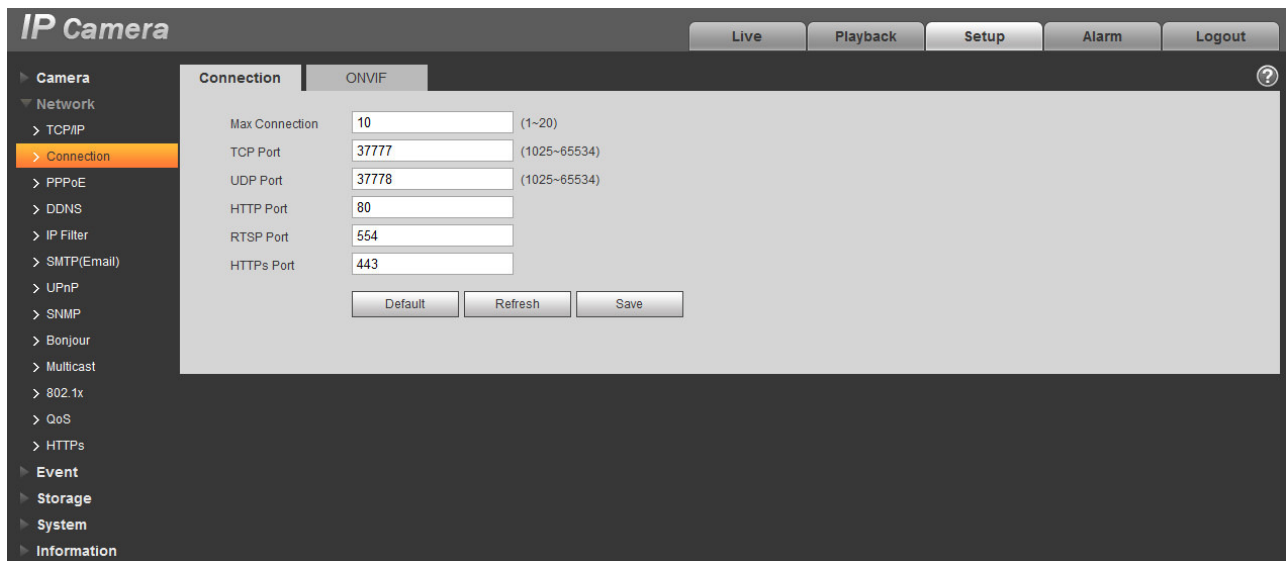

Figure 5-31

Please refer to the following sheet for detailed information.

Parameter	Function
Max connection	It is the max Web connection for the same device. The value ranges from 1 to 20. Default connection amount is 10.
TCP port	Port range is 1025~65534. The default value is 37777. You can input the actual port number if necessary.
UDP port	Port range is 1025~65534. The default value is 37778. You can input the actual port number if necessary.
HTTP port	Port range is 1025~65524. The default value is 80. You can input the actual port number if necessary.
RTSP port	<ul style="list-style-type: none"> ● The default value is 554. Please leave blank if use default. User uses QuickTime or VLC can play the following formats. BlackBerry can play too. ● Real-time monitoring URL format, please require real-time RTSP media server, require channel no., bit stream type in URL. You may need username and password. ● User uses BlackBerry need to set encode mode to H.264B, resolution to CIF and turn off audio. <p>URL format is: rtsp://username:password@ip:port/cam/realmonitor?channel=1&subtype=0 Username/password/IP and port. The IP is device IP and the port default value is 554. You can leave it in blank if it is the default value. Follow standard RTP protocol and when encode mode is MJPEG, the max resolution only supports 2040*2040.</p>
HTTPs Port	HTTPs communication port, range is 1025~65534, default is 443.

Note:

- 0~1024, 37780~37880, 1900, 3800, 5000, 5050, 9999, 37776, 39999, 42323 are all special ports. User cannot modify them.
- Avoid using default port value of other ports.

5.2.2.2 ONVIF

ONVIF (Open Network Video Interface Forum), this standard describes network video mode, interface, data type and data interaction mode. ONVIF Standard's aim is to achieve a network video frame agreement and makes the network video products (including video front-end, video equipment, etc.) from different manufacturers completely compatible.

ONVIF function is on by default.

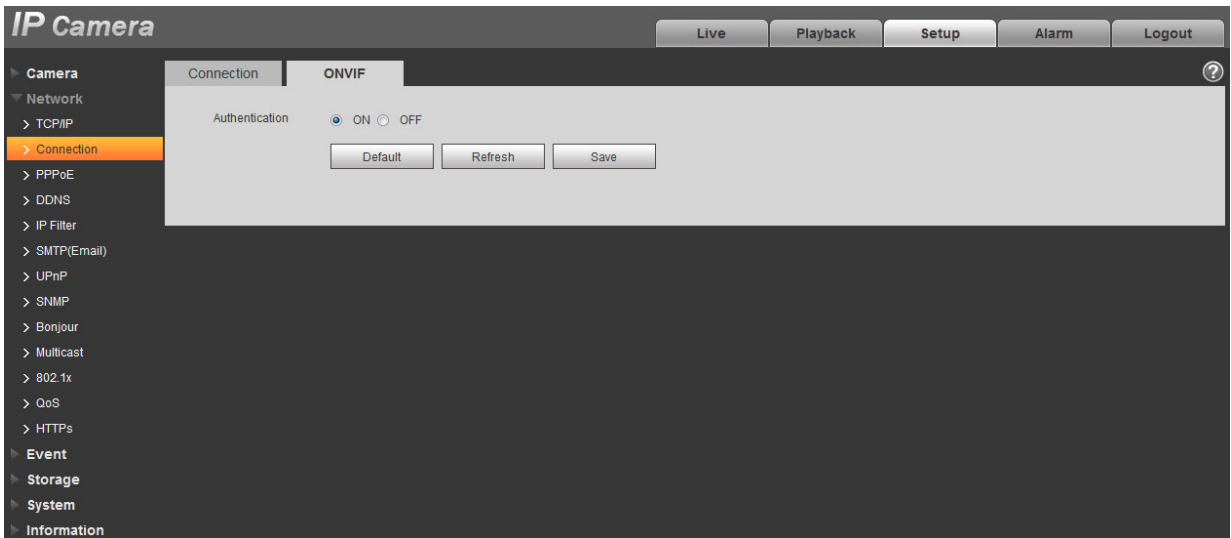

Figure 5-32

5.2.3 PPPoE

The PPPoE interface is shown as in Figure 5-33.

Enter the PPPoE username and password which are provided by ISP (Internet Service Provider), and click “Enable”. The network camera will automatically establish network connection in the mode of PPPoE after it is enabled, after it is successful, the IP of the “IP Address” will be automatically modified into the dynamic IP address of the acquired WAN.

Note:

After PPPoE dial-up is successful, it needs to log in the device via the IP which is set before dial-up; in the PPPoE setup interface, it will display the registered IP address, and then it can visit the IP address via client.

Please disable UPnP when clicking PPPoE enable, which is to avoid causing influence to PPPoE dial-up.

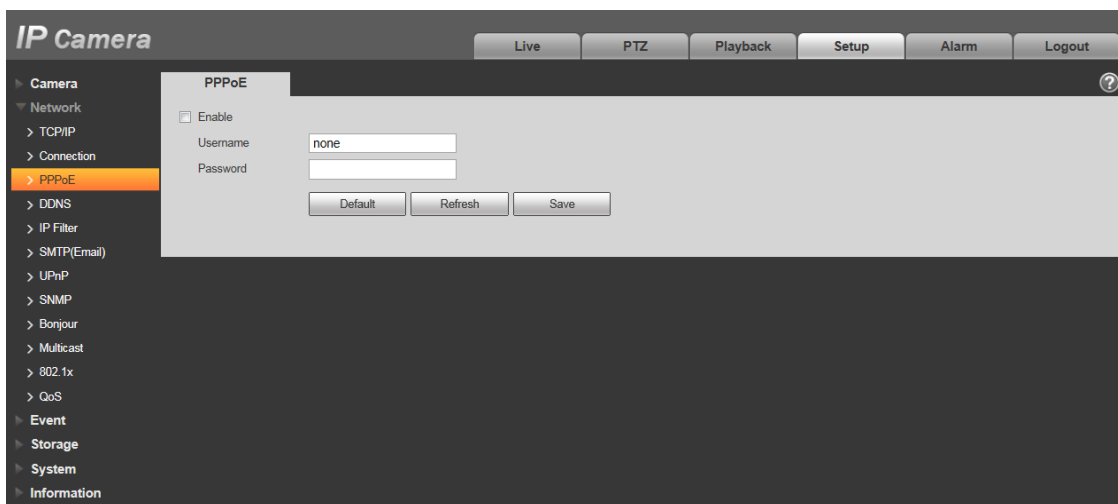

Figure 5-33

5.2.4 DDNS

The DDNS interface is shown as in Figure 5-34.

The DDNS is to set to connect the various servers so that you can access the system via the server. Please go to the corresponding service website to apply a domain name and then access the system via the domain. It works even your IP address has changed. When the device connects to WLAN, you should disable UPnP.

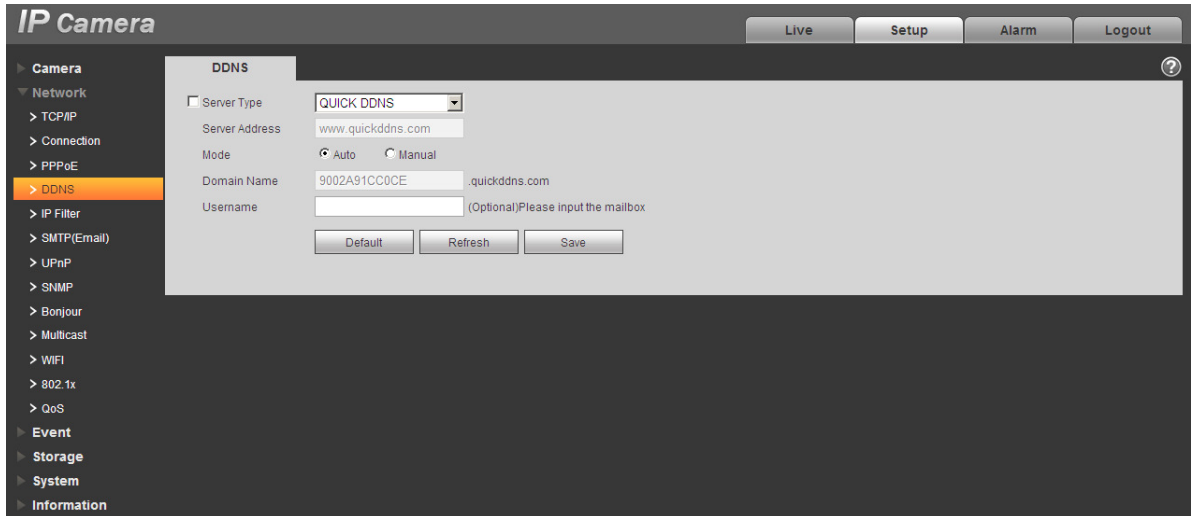

Figure 5-34

Please refer to the following sheet for detailed information.

Parameter	Function
Server Type	Click it to select DDNS protocol type, which includes: CN99 DDNS, NO-IP DDNS, Dyn dns DDNS, Quick DDNS, the default is Quick DDNS.
Server Address	DDNS server IP address CN99 DDNS Server address: www.3322.org NO-IP DDNS Server address: dynupdate.no-ip.com Dyn dns DDNS Server address: members.dyndns.org Quick DDNS Server address: www.quickddns.com
Mode	Default is auto, it can select manual

Parameter	Function
Domain Name	Both auto and manual are “MAC addresss.quickddns.com” by default, it is able to set prefix manually.
Username	The user name you input to log in the server, optional.

The CN99 DDNS interface is shown as in Figure 5-35.

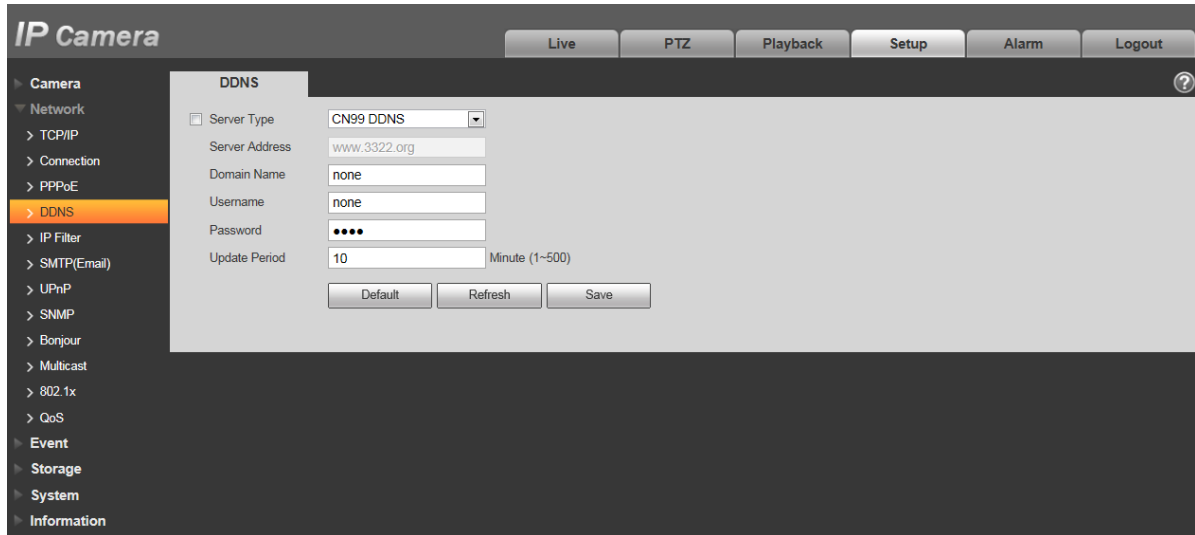

Figure 5-35

Parameter	Function
Server Type	You can select CN99 DDNS protocol
Server Address	Under CN99 DDNS, the default server address is “www. 3322. org”.
Domain Name	Self-defined domain name
Username	The user name you input to log in the server.
Password	The password you input to log in the server
Refresh Period	The refresh period of the connection between the device IP and the server, default is 10 minutes.

5.2.5 IP filter

The IP filter interface is shown as in Figure 5-36.

You can enable IP filter function so that some specified IP/MAC user can access the network camera.

You can add IP address or IP segment.

If you do not check the box here, it means there is on access limit.

Here you can add IP address and MAC address. You must add these addresses before enabling the trusted sites.

Please note: You must set MAC address in the same network segment.

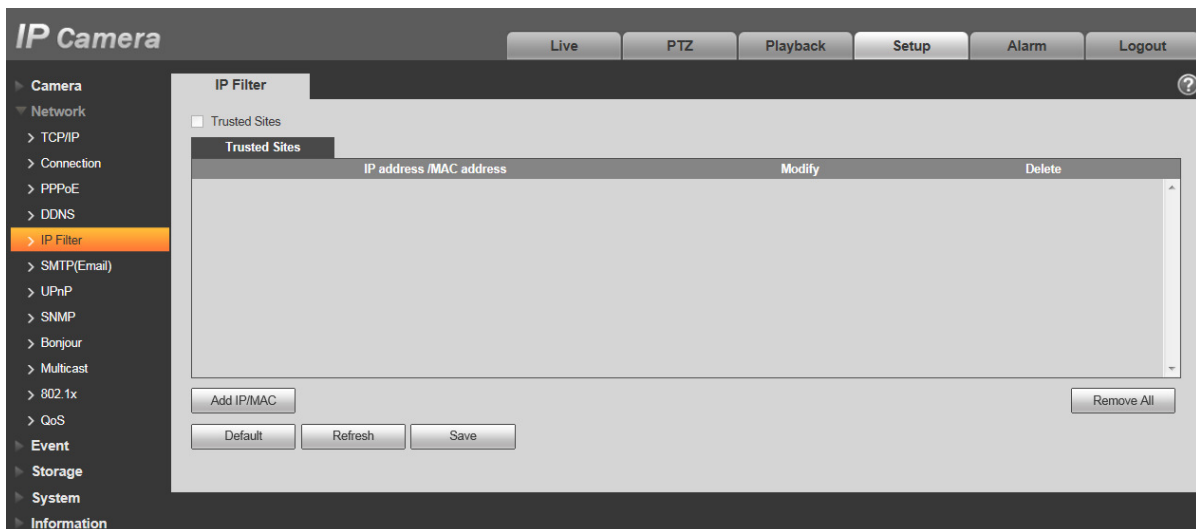

Figure 5-36

5.2.6 SMTP (e-mail)

The SMTP interface is shown as in Figure 5-37.

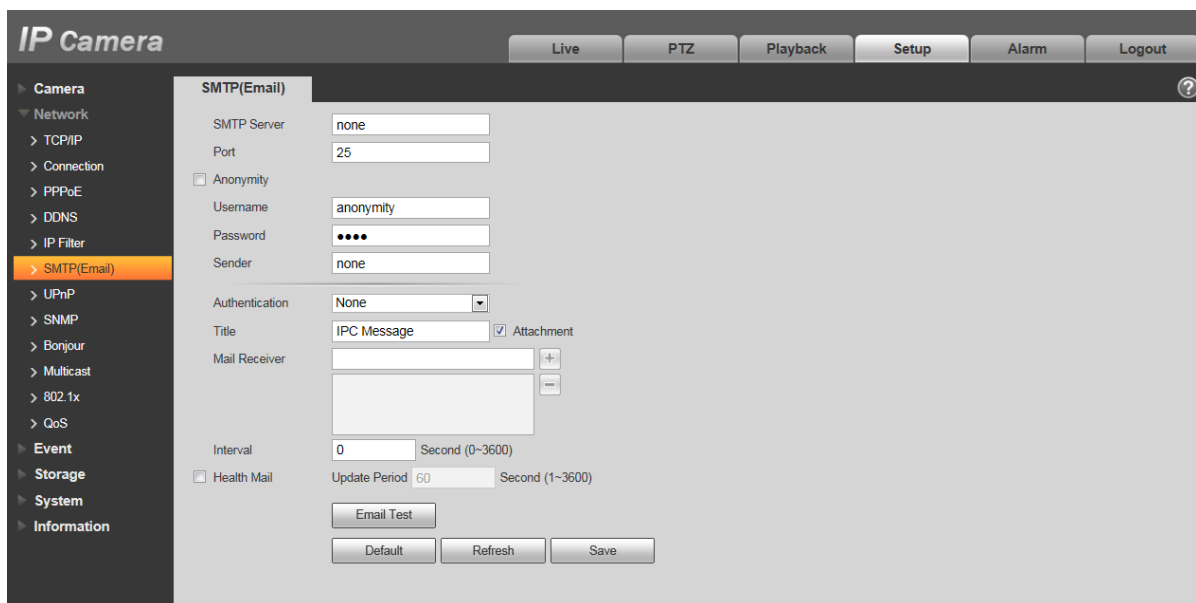

Figure 5-37

Please refer to the following sheet for detailed information.

Parameter	Function
SMTP Server	Input server address and then enable this function.
Port	Default value is 25. You can modify it if necessary.
Anonymity	For the server which supports the anonymity email function, it won't display the information of the sender.
User Name	The user name of the sender email account.
Password	The password of sender email account.
Sender	Sender email address.
Authentication (Encryption mode)	You can select SSL, TLS or none.
Title (Subject)	Input email subject here.
Attachment	System can send out the email of the snapshot picture once you check the box here.
Mail receiver	Input receiver email address here. Max three addresses.
Interval	The send interval ranges from 0 to 3600 seconds. 0 means there is no interval. Please note system will not send out the email immediately when the alarm occurs. When the alarm, motion detection or the abnormality event activates the email, system sends out the email according to the interval you specified here. This function is very useful when there are too many emails activated by the abnormality events, which may result in heavy load for the email server.
Health mail enable	Please check the box here to enable this function.
Email test	The system will automatically sent out a email once to test the connection is OK or not .Before the email test, please save the email setup information.

5.2.7 UPnP

It allows you to establish the mapping relationship between the LAN and the public network.

Here you can also add, modify or remove UPnP item. For UPnP on different routers, you must disable UPnP function. See Figure 5-38.

In the Windows OS, From Start->Control Panel->Add or remove programs. Click the "Add/Remove Windows Components" and then select the "Network Services" from the Windows Components Wizard. Click the Details button and then check the "Internet Gateway Device Discovery and Control client" and "UPnP User Interface". Please click OK to begin installation.

Enable UPnP from the Web. If your UPnP is enabled in the Windows OS, the network camera can auto detect it via the “My Network Places”.

Under manual mode, you can modify external port. Under auto mode, select idle port for auto port mapping without user modification.

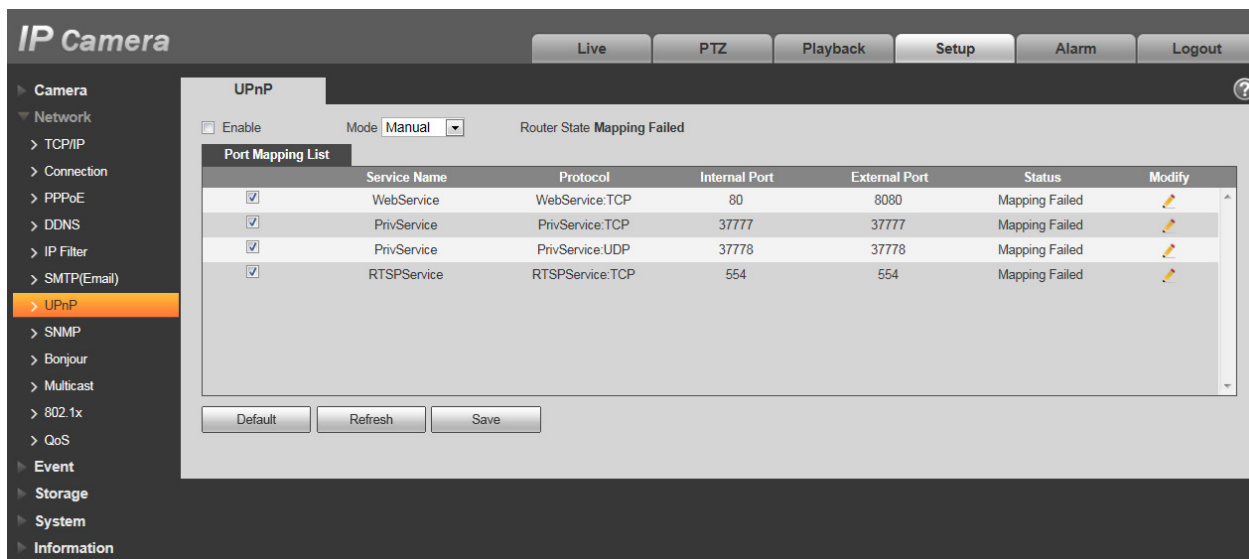

Figure 5-38

5.2.8 SNMP

The SNMP interface is shown as in Figure 5-39 and Figure 5-40.

The SNMP allows the communication between the network management work station software and the proxy of the managed device. Please install the software such as MG MibBrowser 8.0c software or establish the SNMP service before you use this function. You need to reboot the device to activate the new setup.

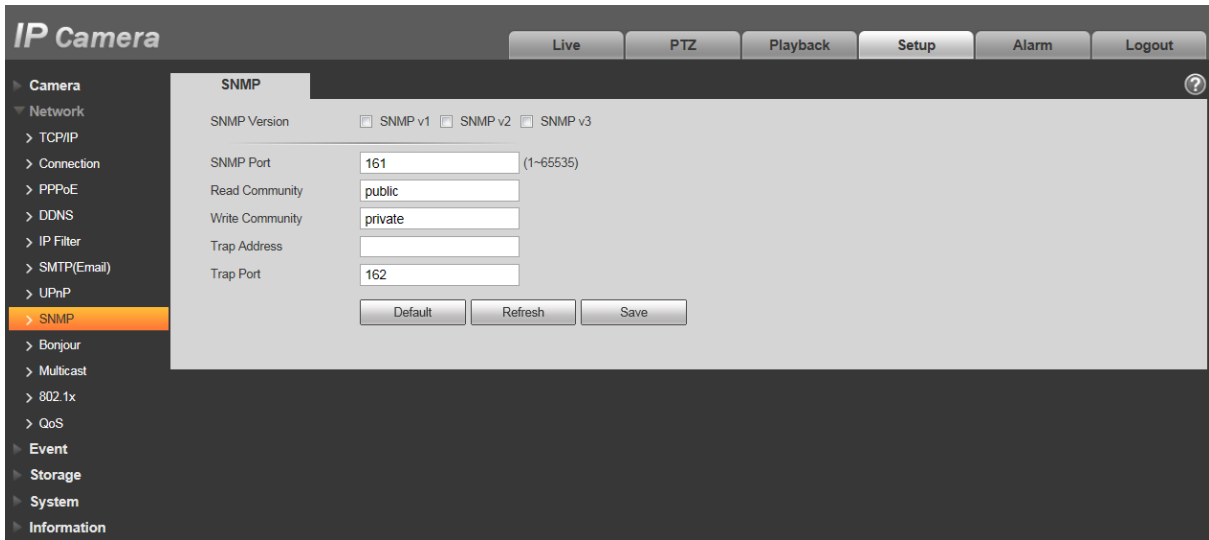

Figure 5-39

Please refer to the following sheet for detailed information.

Parameter	Function
SNMP Version	<ul style="list-style-type: none"> ● Check SNMP v1, device only process v1 info. ● Check SNMP v2, device only process v2 info. ● Check SNMP v3, can set username, password and encryption method. Server calibrate corresponding username, password and encryption method too access device and v1/v2 are unavailable.
SNMP port	The listening port of the proxy program of the device. It is a UDP port not a TCP port. The value ranges from 1 to 65535. The default value is 161
Community	It is a string, as command between management and proxy, , defining a proxy, and a manager's authentication.
Read community	Read-only access to all SNMP targets, default is public. Note: Only number, letter, _, and – supported.
Write community	Read/write access to all SNMP targets, default is private. Note: Only number, letter, _, and – supported.
Trap address	The destination address of the Trap information from the proxy program of the device.
Trap	SNMP trap is a proxy message sent to admin as important event notice or status change.
Trap Address	Address where to send Trap message.
Trap Port	Port which send Trap message, default is 162, range 1~65535.

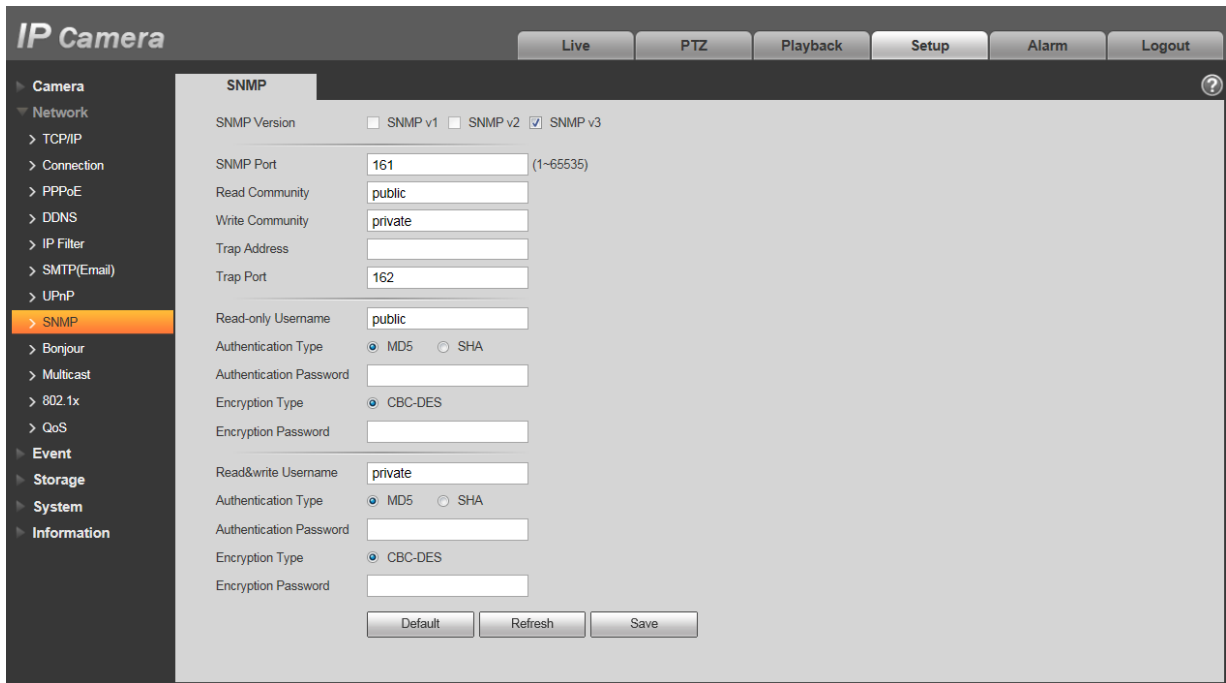

Figure 5-40

Check SNMP v3 version and SNMP port, read community, write community, Trap address, Trap port are same with SNMP v1 and SNMP v2 versions. Only when SNMP version is SNMP v3, users need to configure parameter in chart.

Parameter	Function
SNMP Version	SNMP v3
Read-only Username	Default is public. Note: Name only can be number, letter and underline.
Read/Write Username	Default is private. Note: Name only can be number, letter and underline.
Authentication	You may select MD5 or SHA, default is MD5.
Authentication Password	Password not less than 8 characters.
Encryption	Default is CBC-DES.
Encryption Password	Password not less than 8 characters.

5.2.9 Bonjour

The Bonjour interface is shown as below. See Figure 5-41.

Bonjour is based on the multicast DNS service from the Apple. The Bonjour device can automatically broadcast its service information and listen to the service information from other device.

You can use the browse of the Bonjour service in the same LAN to search the network camera device and then access if you do not know the network camera information such as IP address.

You can view the server name when the network camera is detected by the Bonjour. Please note the safari browse support this function. Click the “Display All Bookmarks: and open the Bonjour, system can auto detect the network camera of the Bonjour function in the LAN.

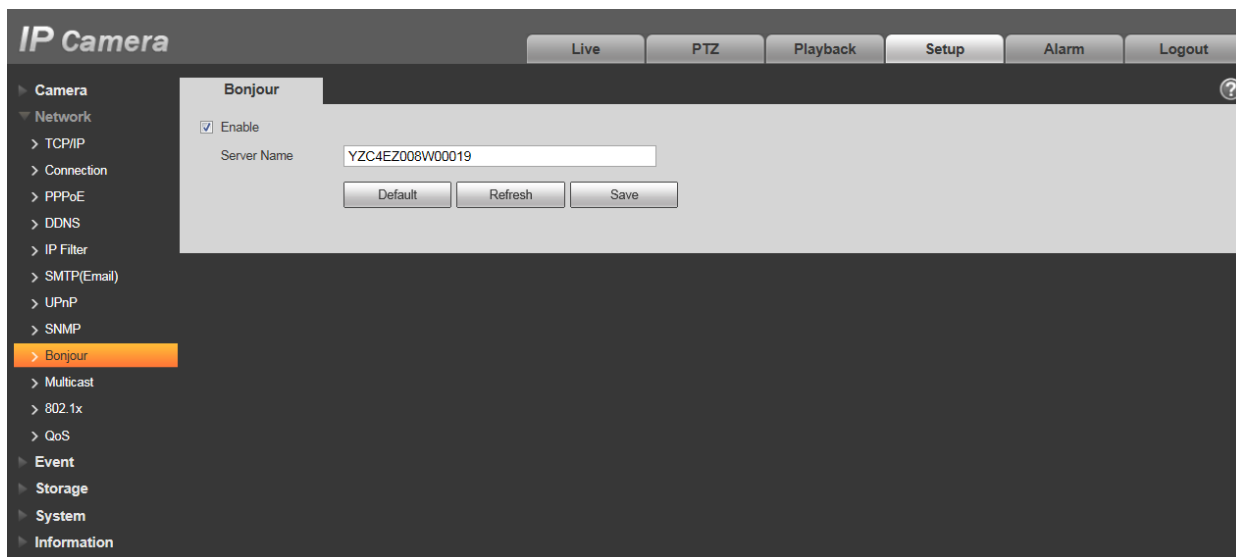

Figure 5-41

5.2.10 Multicast

The multicast interface is shown as in Figure 5-42.

Multicast is a transmission mode of data packet. When there is multiple-host to receive the same data packet, multiple-cast is the best option to reduce the broad width and the CPU load. The source host can just send out one data to transit. This function also depends on the relationship of the group member and group of the outer.

Note:

- Open preview, streaming media protocol, select multicast, and monitor via multicast format.
- Here you can set multicast address and port. You also need to go to Live interface to set the protocol as Multicast.

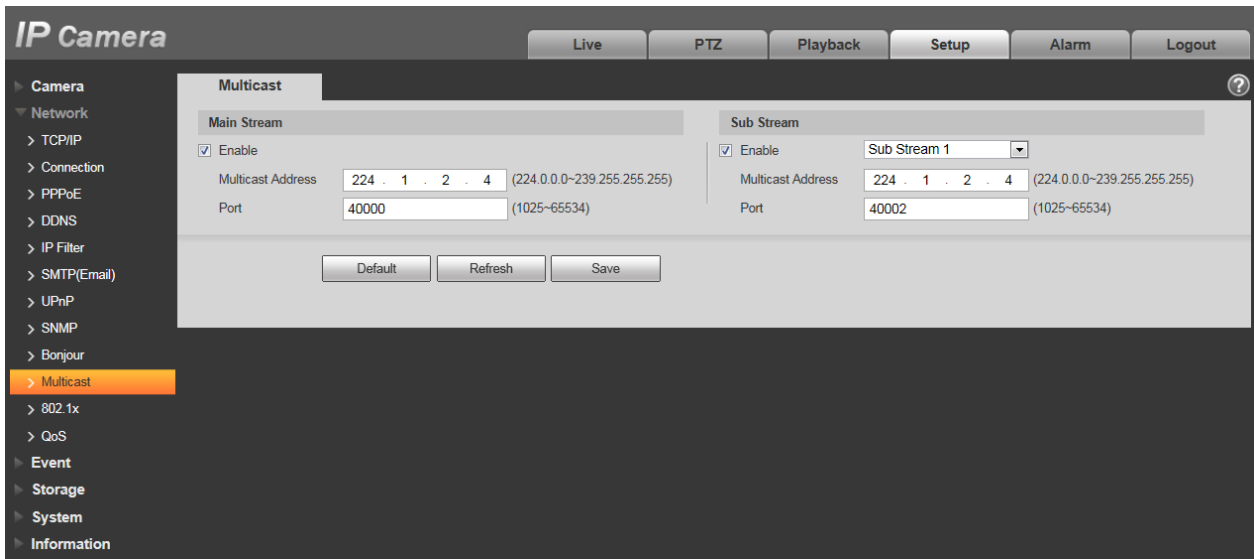

Figure 5-42

Please refer to the following sheet for detailed information.

Parameter	Function
Enable	Select to enable multicast function. Main stream and sub stream cannot be used at the same time.
Multicast address	Main/sub stream multicast default address is 224.1.2.4 and its range is 224.0.0.0~239.255.255.255.
Port	Multicast port. Main stream is 40000, sub stream1 is 40016, sub stream2 is 40032 and the range is 1025~65534.

5.2.11 4G

Note: This function is only for series with 4G module.

4G is a mobile communication system which makes wireless communication integrates with Internet and multimedia communication.

5.2.11.1 Dialing Setting

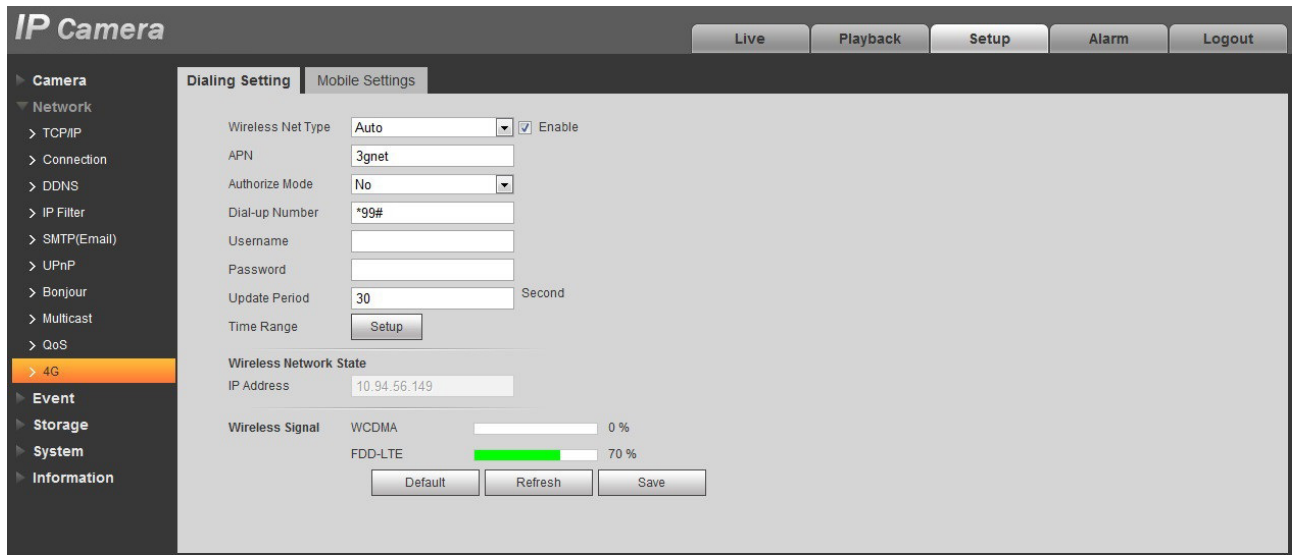

Figure 4-53

Parameter	Function
Wireless Net Type	Auto, WCDMA, FDD-LTE optional, you can select according to the operator.
Enable	Check to enable 4G module.
APN	It shall be acquired from the operator according to the setup of operator.
Authentication Mode	Auto, PAP and CHAP, the authentication algorithm is different according to different operators.
Dial-up Number	The number is different according to different operator, it can be acquired from operator.
User name	It shall be acquired from the operator.
Password	It shall be acquired from the operator.
Update Period	It is the period beyond the dial-up period which has been set, it is 30s by default, which means the device can auto acquire 4G dial-up status, cut off dial-up to save flow.
Time Range	It is the time period to set dial-up. It can activate the function via message to enable/disable dial-up function if it is beyond the time period.
IP Address	It will display the acquired IP after the dial-up is successful via 4G.

5.2.11.2 Mobile Setting

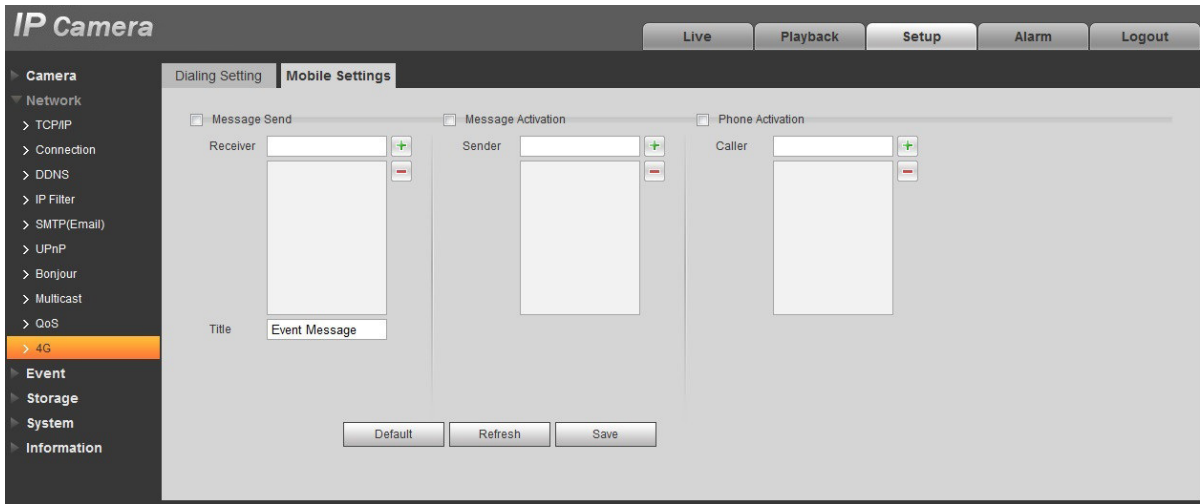

Figure 4-54

Please refer to the following sheet for detailed information.

Parameter	Function
Message Send	In the event, after the corresponding message activation is enabled, it will send message to the phone of receiver when event happens. It needs to enable the function of message activation function in the event interface when using the function.
Message Activation	It can send message ON/OFF to the SIM card inside the device by the mobile phone in the list, which is to enable /disable the dial-up function and send REBOOT to restart the device.
Phone Activation	You can use the mobile phone in the calling list to call the SIM card inside the device to enable dial-up function.

5.2.12 WIFI

Note:

Some series devices don't support WIFI and WPS function.
WPS function is supported by the devices with WPS button.

5.2.12.1 WIFI

WIFI info can show the name, status, IP information of the Current Hot Spot. Usually please "Refresh" WIFI work information after reconnection to ensure the real-time display of the work status, because it often takes some time to connect WIFI Hot Spot, which depends on the network signal strength.



Figure 5-45

WiFi setting method is as follows:

Step 1

Click Enable, show as Enable, means enabling WiFi function.

Step 2

Click "Search SSID", and shows the wireless network hot spot of the current network camera environment in the list.

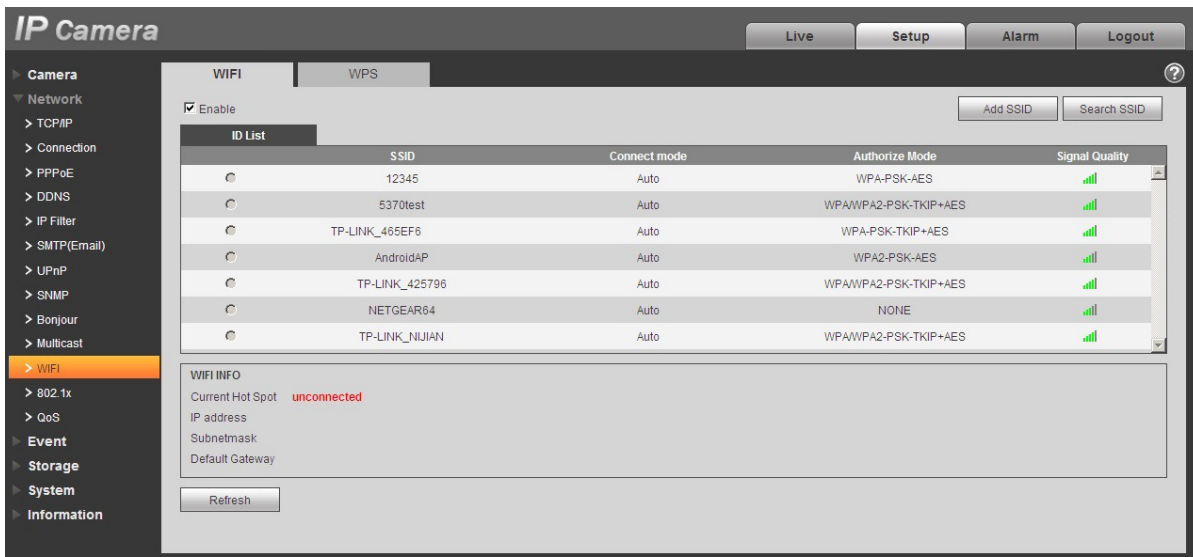

Figure 5-46

Step 3

Click “Add SSID” when need to add a wireless network manually, pop out an interface in the figure below, and enter network ID in the dialog box.

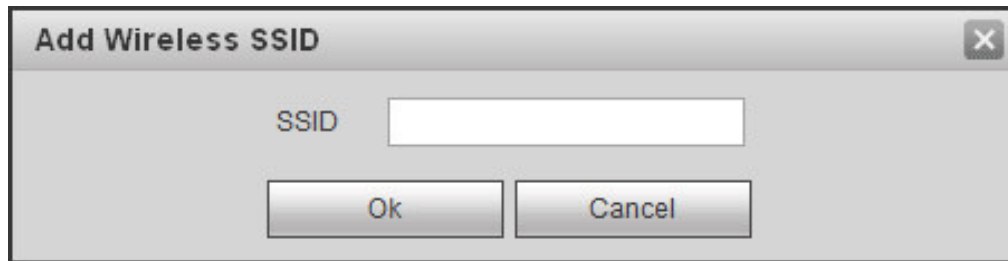

Figure 5-47

Step 4 Double click on one can pop out the signal intensity and authentication of the hot spot.

- Please enter the password if necessary. Please keep the choice of password index number same as the router when entering password.
- Please click “connect” if it is unnecessary to enter the password.

5.2.12.2 WPS

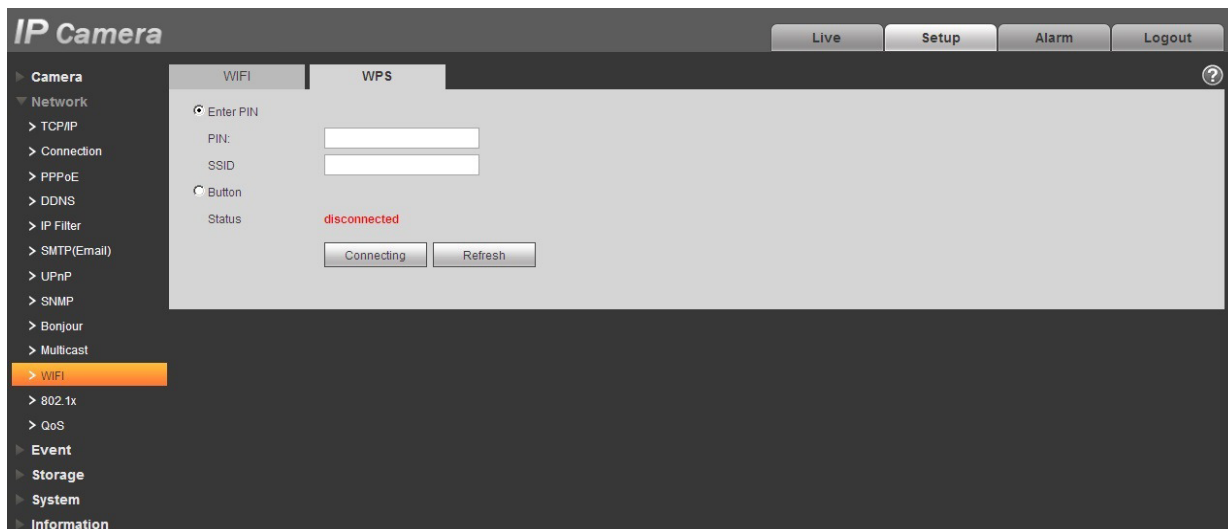

Figure 5-48

PIN Number and SSID are both acquired from the router, please “refresh” the work information of WIFI to ensure the real-time display of work state after filling in correctly.

5.2.13 802.1x

802.1x (port based network access control protocol) supports manual selection of authentication method to control if device connected to LAN can join the LAN. It well supports authentication, charging, safety and management requirement of network.

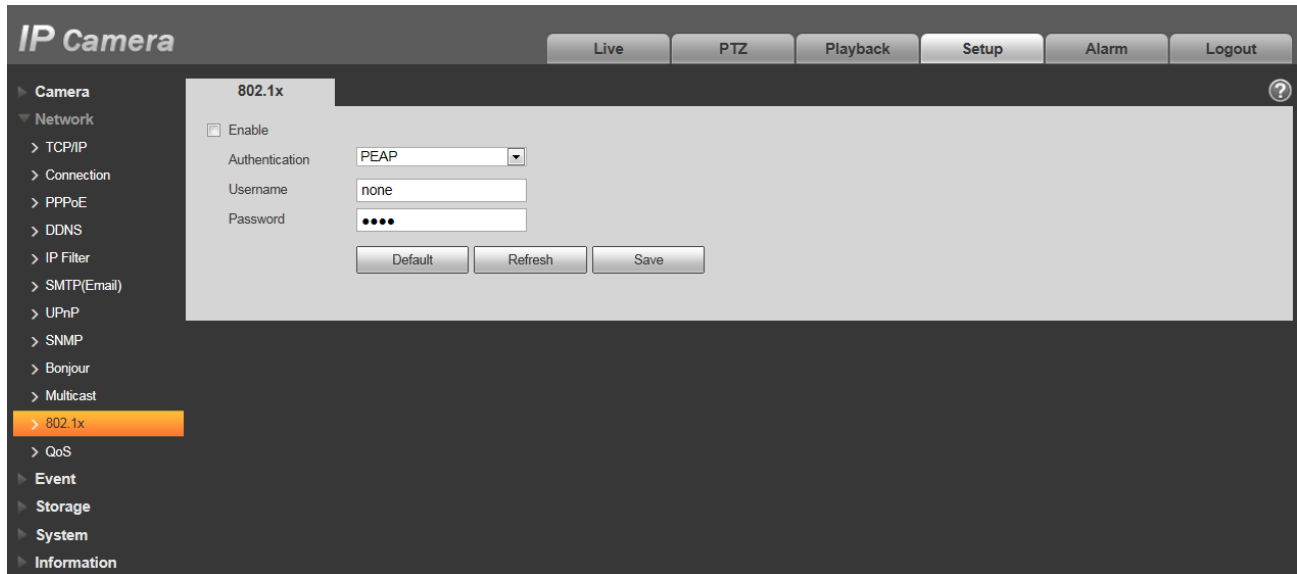

Figure 5-49

Please refer to the following sheet for detailed information.

Parameter	Function
Authentication	PEAP (protected EAP protocol).
Username	It needs the username to login, which is authenticated by the server.
Password	Please input password here.

5.2.14 QoS

The QoS interface is shown as below. See Figure 5-50.

Qos (Quality of Service) is network security mechanism. It is a technology to fix the network delay and jam problem and etc. For the network service, the quality of service includes the transmission bandwidth, delay, the packet loss and etc. We can guarantee the transmission bandwidth, lower the delay, and reduce the loss of the data packet and anti-dither to enhance the quality.

We can set the DSCP (Differentiated Services Code Point) of the IP to distinguish the data packet so that the router or the hub can provide different services for various data packets. It can select the different queues according to the priority (64 different priority levels) of the packets and select the bandwidth of the each queue. Level 0 is the lowest, and level 63 is the highest. It can also discard at the different ratio when the broad bandwidth is jam.

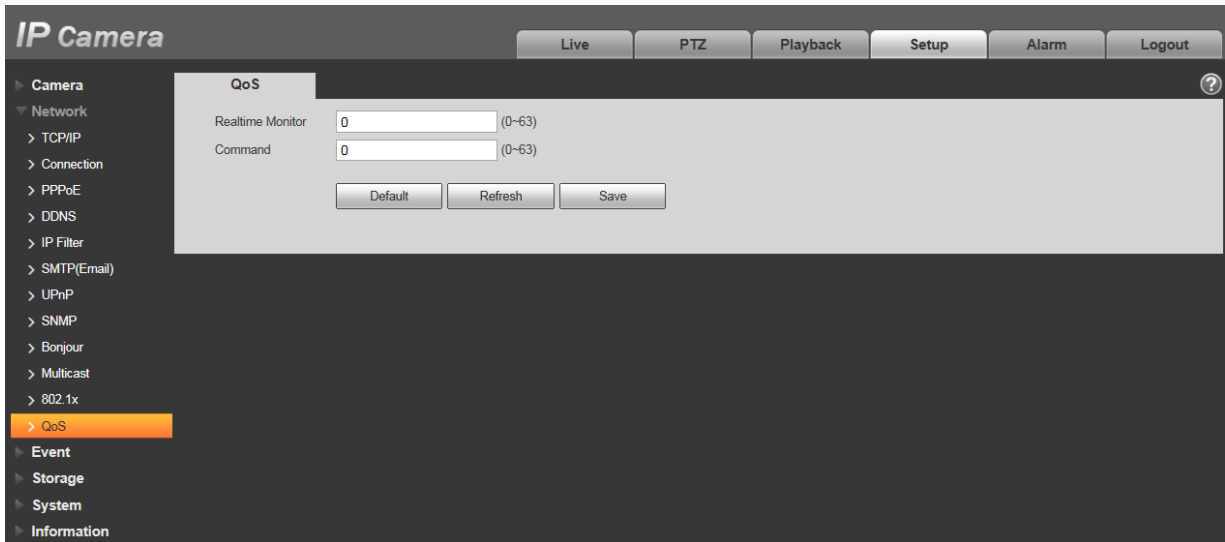

Figure 5-50

Please refer to the following sheet for detailed information.

Parameter	Function
Real-time monitor	The value ranges from 0 to 63. The router or the switcher can provide different service for various data packets.
Command	The value ranges from 0 to 63. The router or the switcher can provide different service for various data packets.
Enable Wireless QoS	Check it to enable QoS.

5.2.15 HTTPs

In the HTTPs setting interface, users can make PC log in normally via HTTPs by creating certificate or uploading signed certificate, which is to guarantee the security of communication data and provide safeguard for user information and device security with reliable and stable technical means.

Step 1

Create certificate or upload the signed certificate.

- Please refer to the following steps if you select “Create Certificate”.

1. Select “Setup > Network > HTTPs”, and the system will display the interface of HTTPs, which is shown in Figure 5-51.

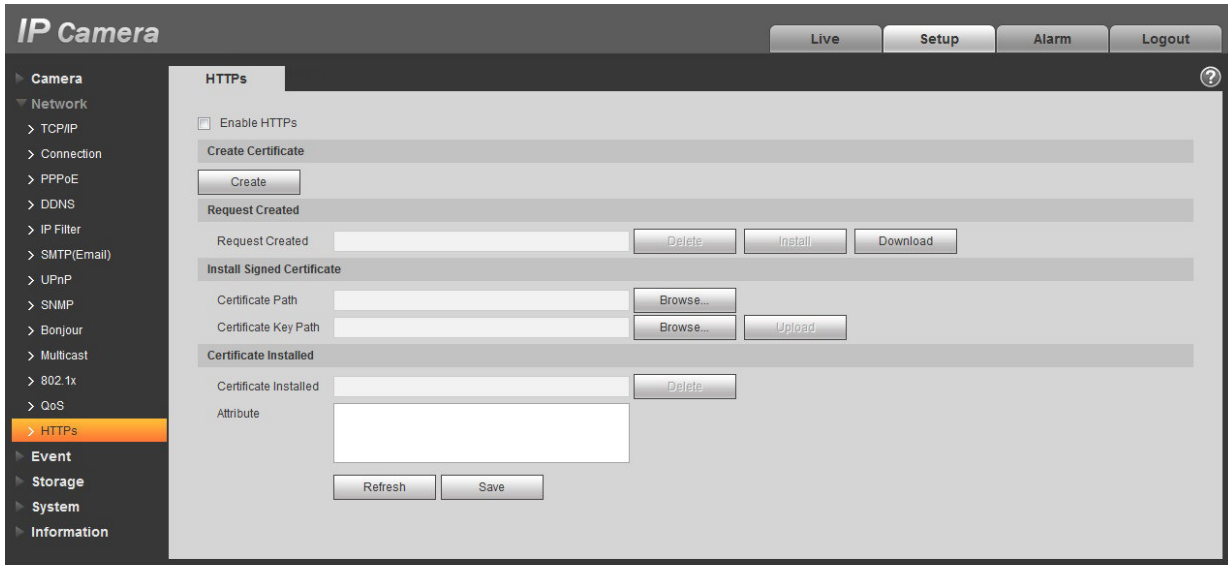

Figure 5-51

- Click “Create” and it will pop out the dialog box of “HTTPs”, which is shown in Figure 5-52.

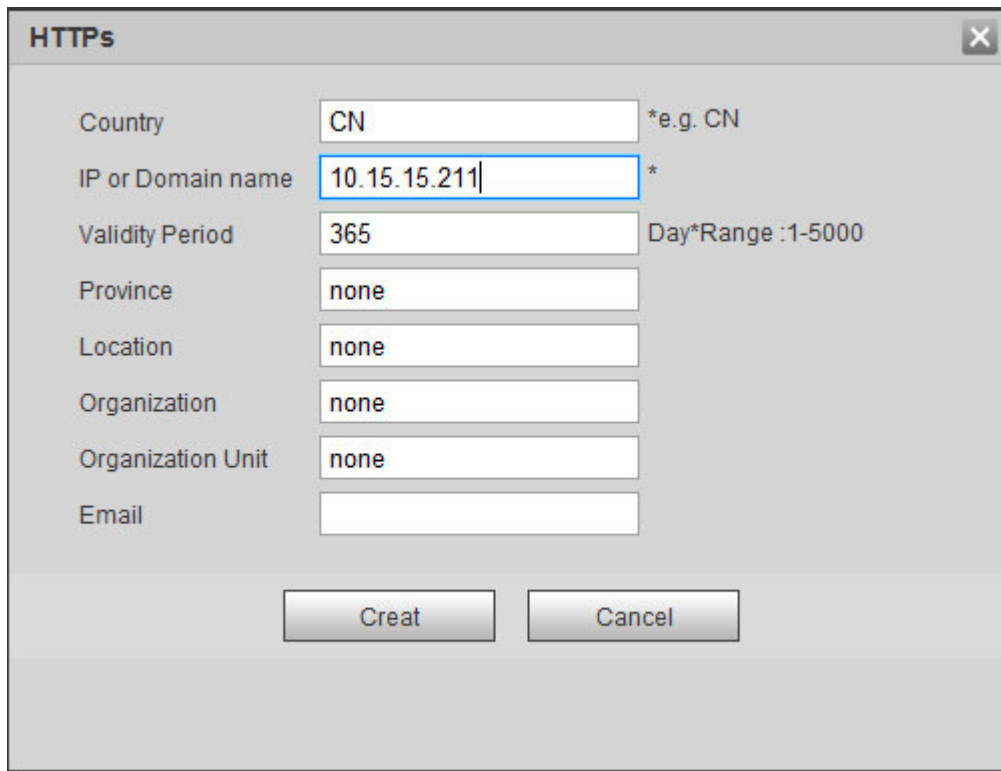

Figure 5-52

- Fill in corresponding “Country”, “Province” and some other information, click “Create” after filling in. It will show the prompt of “Create Successfully”, which means the server certificate has been successfully created.

Note:

Make sure the “IP or domain name” is the same as that of the device.

4. Click “Install” and it will install the certificate on the device end, which is shown in Figure 5-53.

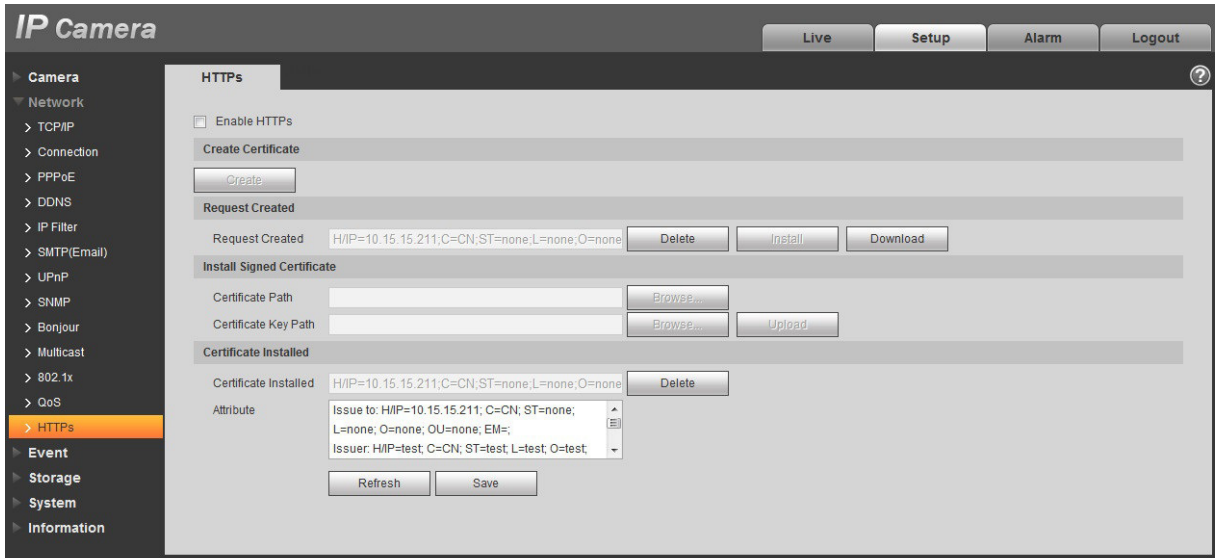

Figure 5-53

5. Click “Download”. It will pop out the dialog box of “Save as”, save the file into the computer.

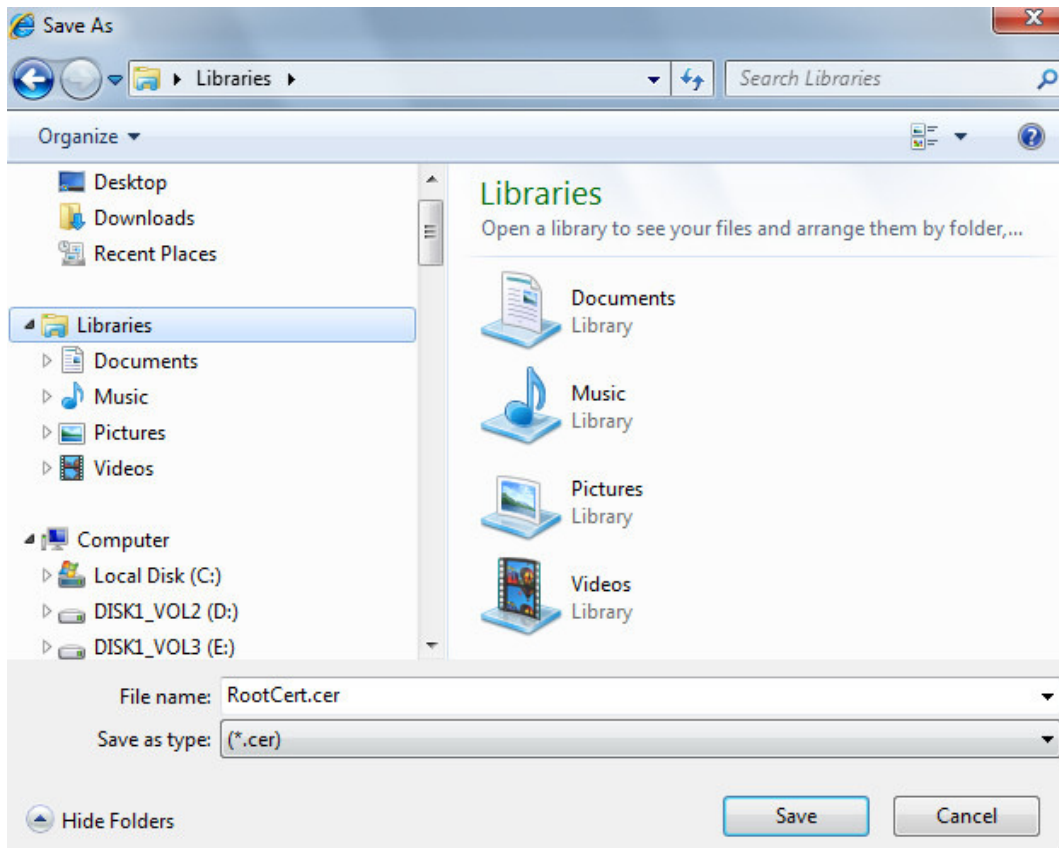

Figure 5-54

6. Double click the downloaded icon of "RootCert.cer". The system will display the information interface of "Certificate", which is shown in Figure 5-55.

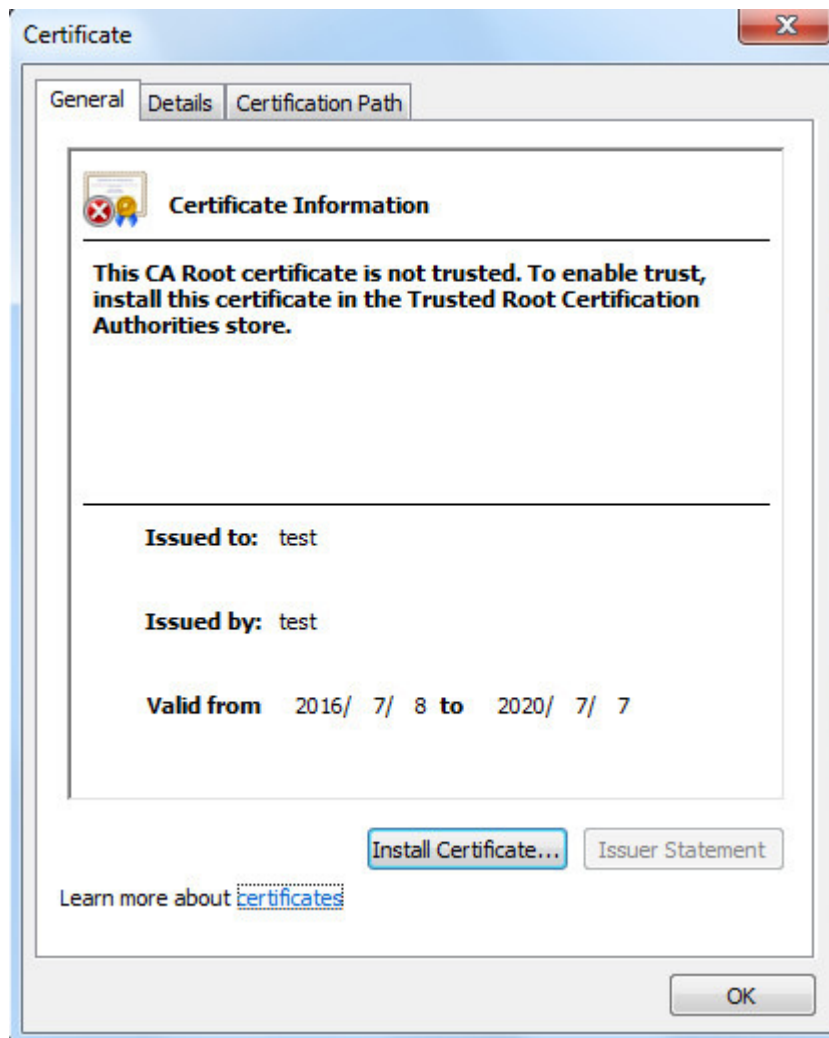

Figure 5-55

7. Click "Install Certificate" and it will pop out the interface of "Certificate Import Wizard", which is shown in Figure 5-56.

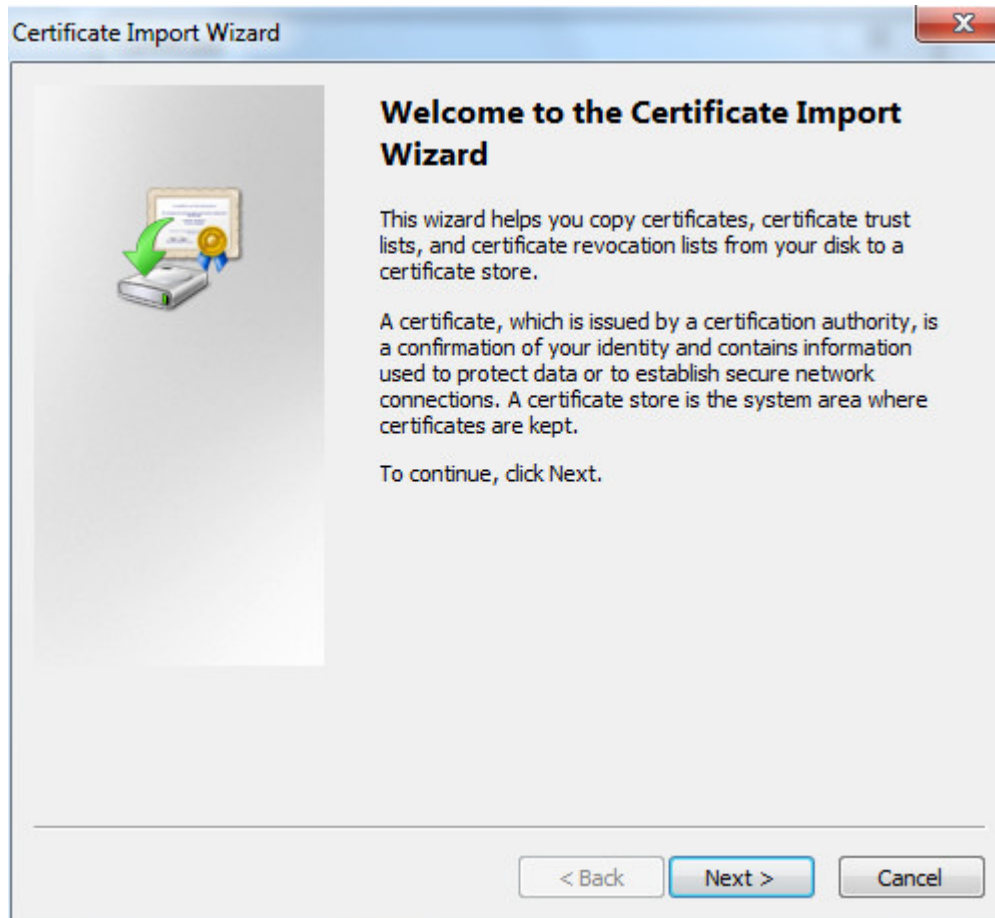

Figure 5-56

8. Click "Next". Select "Trusted Root Certification Authorities", which is shown in Figure 5-57.

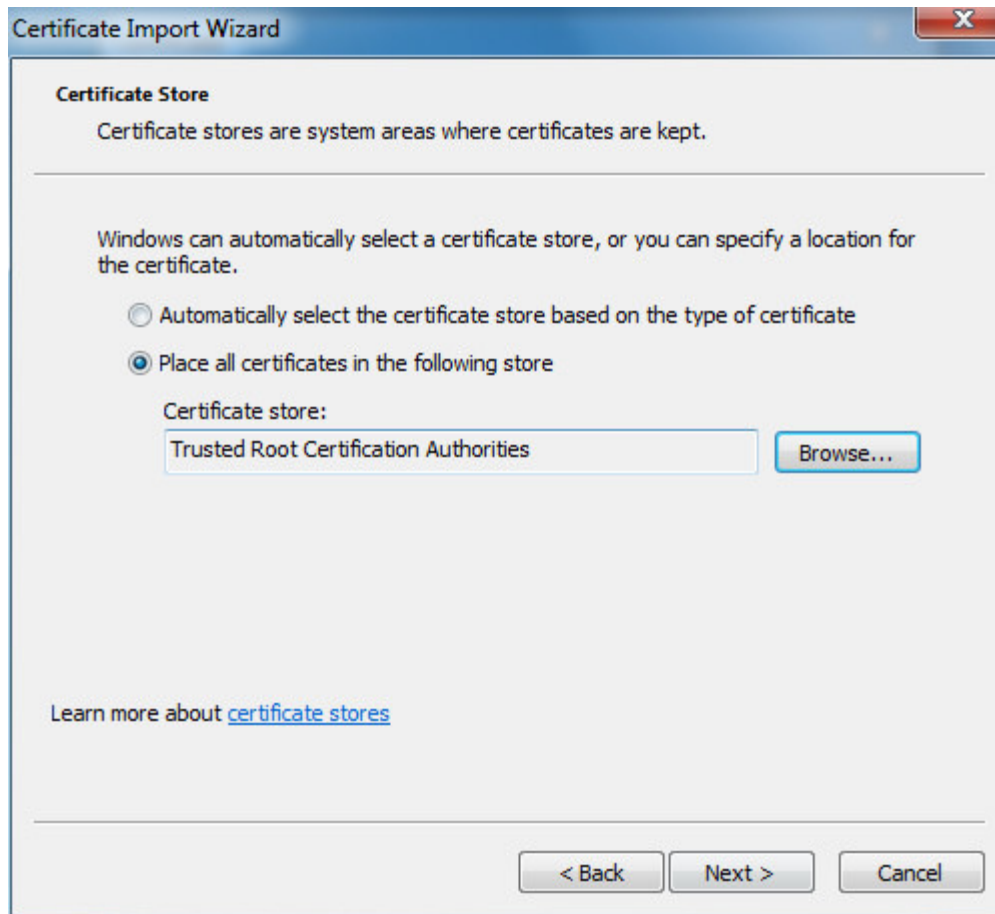

Figure 5-57

9. Click "Next". The system will display the interface of "Completing the Certificate Import Wizard", which is shown in Figure 5-58.

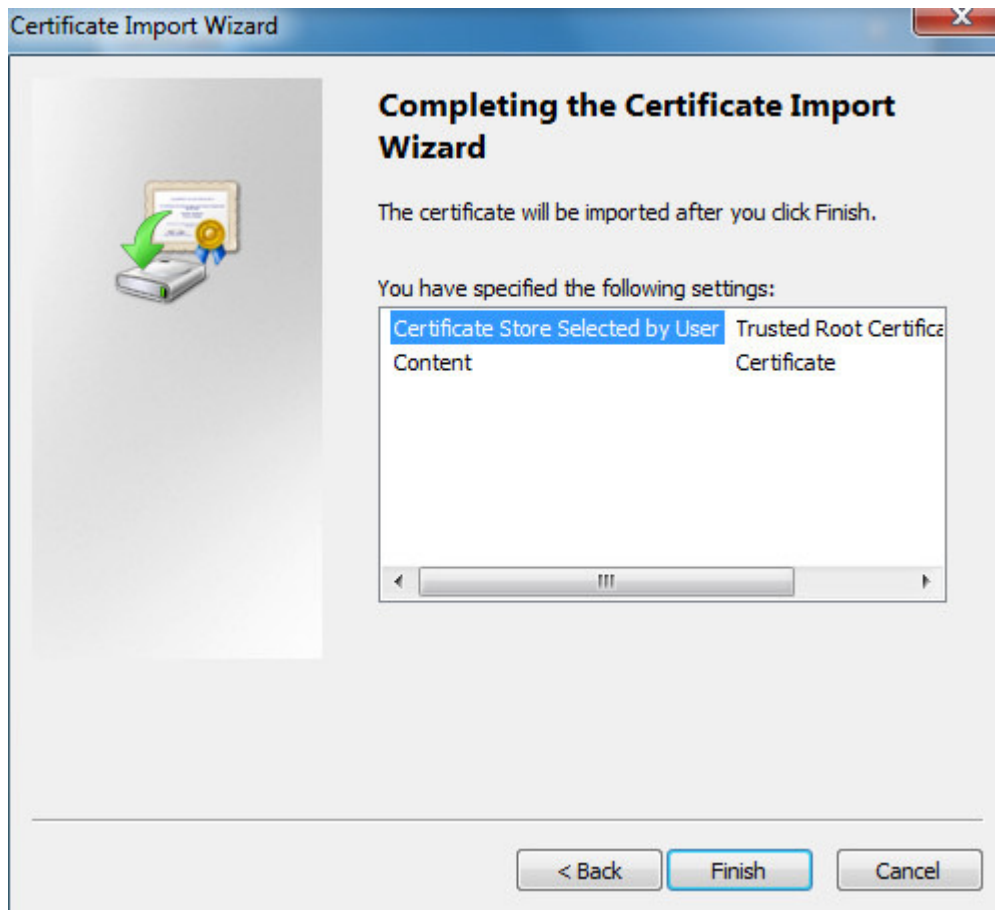

Figure 5-58

10. Click "Finish", and it will pop out the dialog box of "Security Warning", which is shown in Figure 5-59.

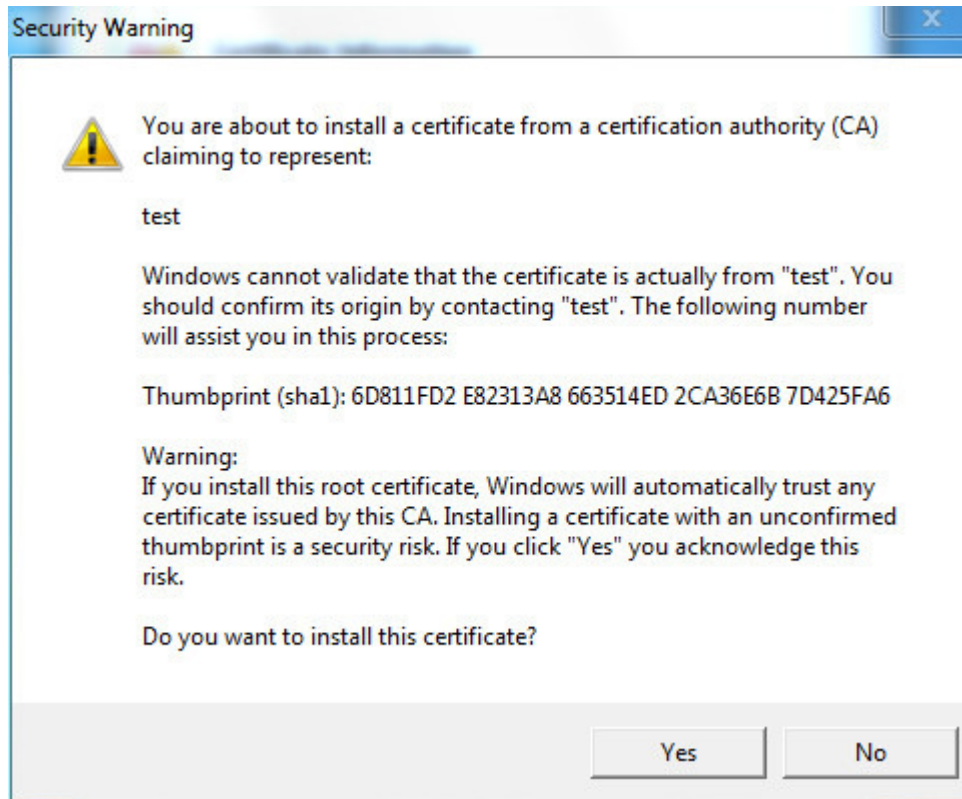

Figure 5-59

11. Click "Yes". It will pop out the dialog box of "Import Successful", click "Ok" to complete downloading certificate, which is shown in Figure 5-60.

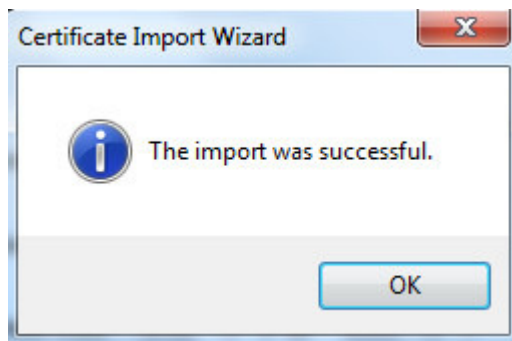

Figure 5-60

- Please refer to the following steps if you select "Install Signed Certificate".
1. Select "Setup > Network > HTTPs". The system will display the interface of HTTPs, which is shown in Figure 5-61.

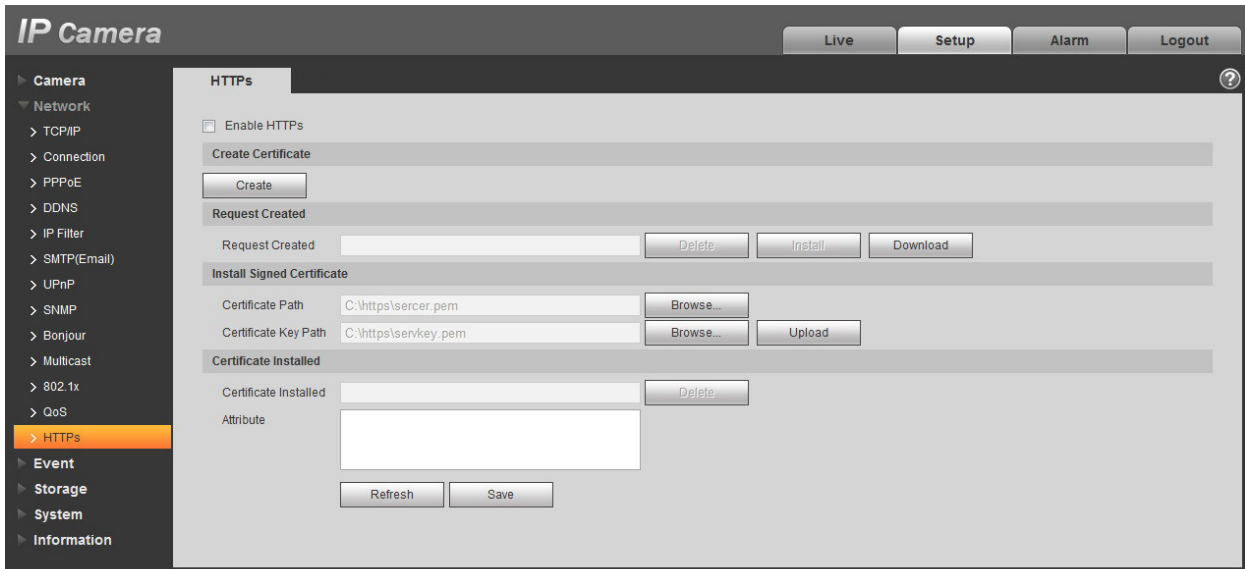

Figure 5-61

2. Select signed certificate and certificate key path respectively via “Browse”, click “Upload”.
3. Install root certificate, please refer to step 6~11 for more details.
4. Check “Enable HTTPs”, click “Save”. The system will display the dialog box of “Need to reboot the device”, and then the config is valid.

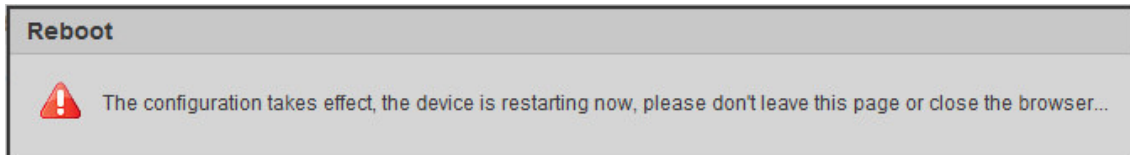

Figure 5-62

5. Use HTTPs

Use HTTPs to log in.

Enter <https://xx.xx.xx.xx> in the browser, and it will pop out normal login interface; the browser will prompt certificate error if the certificate is not installed, which is shown in Figure 5-63.

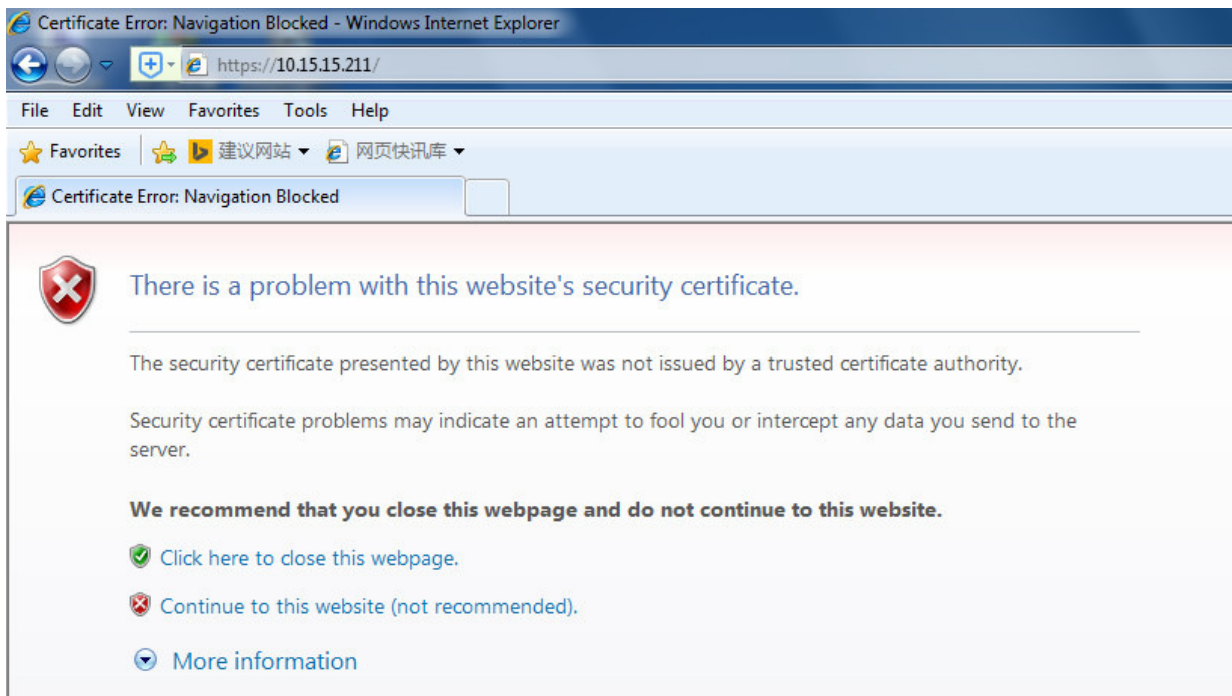

Figure 5-63

Note:

“xx.xx.xx.xx” is corresponding to your IP or domain name.

5.3 Event

5.3.1 Video detection

5.3.1.1 Motion Detection

Step 1

Select “Setup > Event > Video Detection > Motion Detection” and the system will display the interface of “Motion Detection” which is shown in Figure 5-64.

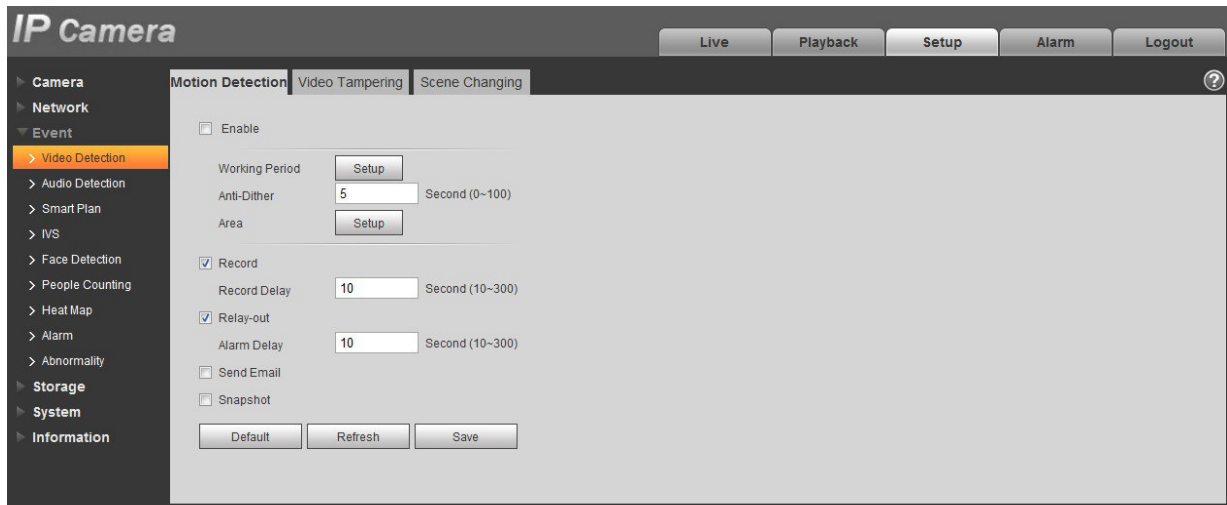

Figure 5-64

Step 2

Select “Enable” to enable motion detection function.

Step 3

Set motion detection area.

1. Click “Setup” and the system will pop out the interface of “Setting Area”, which is shown in Figure 5-65

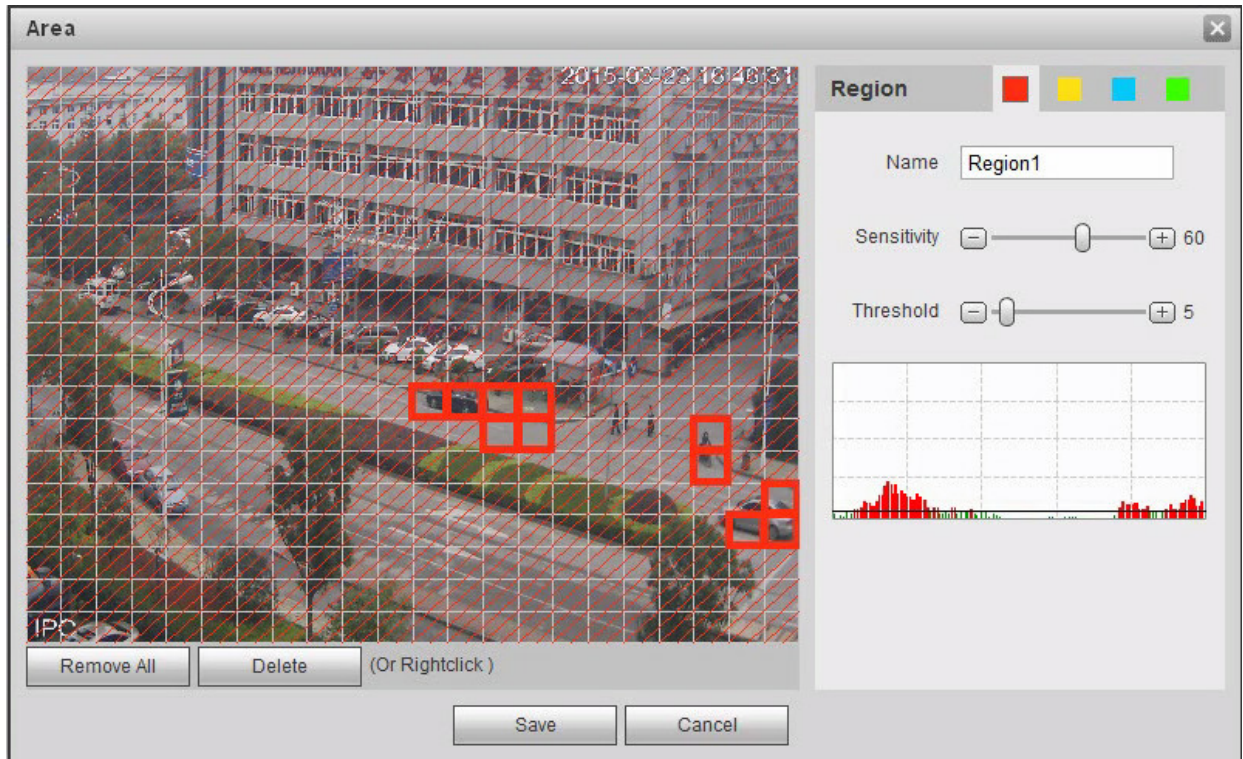

Figure 5-65

2. Set area name, it is to set valid area of motion detection according to the actual situation, and it can set the value of sensitivity and threshold respectively.

The bigger the sensitivity is, the easier it is to generate motion detection, the smaller the threshold is, the easier it is to generate motion detection; the entire video image is the valid area of motion detection by default.

Note:

- Different colors represent different areas; each area can set different detection area.
- The red line in the Oscillogram means triggering motion detection; green line means not triggering motion detection.

3. Click “Save” to complete area setting.

Step 4

It is to set other parameters of motion detection, please refer to the following sheet for more details.

Parameter	Function
Working Period	<p>Note: It is to set the alarm period, it can enable alarm event only during the period range which has been set.</p> <ol style="list-style-type: none"> 1. Click "Setup" and the system will pop out the interface of "Working Period". 2. It is to set working period according to the following methods: <ul style="list-style-type: none"> ● You can input time numerical value or press the left mouse button to drag on the setup interface to set. ● There are six periods to be set every day, select the check box in front of the period, and then the period is valid. ● Select week number (it selects Sunday by default, if it selects the whole week, then it means the setup can be applied to the whole week, you can also select the check box in front of the week number to implement independent setting for some days). 3. Click "Save" to complete the setup of working period.
Anti-dither	System only memorizes one event during the anti-dither period. The value ranges from 0s to 100s.
Area	<ol style="list-style-type: none"> 1. Click "Setup" and the system will pop out the interface of "Set Area". 2. Set the area name, it is to set the valid area of motion detection according to the actual situation, and it can set its sensitivity and threshold respectively. The higher the sensitivity is, the easier it is to trigger motion detect, the smaller the area threshold is, the easier it is to generate motion detect, the whole video image is the valid area of the motion detect by default. <p>Note: Different colors represent different areas; each area can set different detection areas. The red line in the Oscillogram means triggering motion detect, the green line means not triggering motion detect.</p> <ol style="list-style-type: none"> 3. Click "Save" to complete area setup.
Record	Check it and so when alarm occurs, system will auto record. You shall set record period in Storage>Schedule and select auto record in record control interface.
Record Delay	System can delay the record for specified time after alarm ended. The value ranges from 10s to 300s.
Relay out	Enable alarm activation function. You need to select alarm output port so that system can activate corresponding alarm device when alarm occurs.
Alarm Delay	System can delay the alarm output for specified time after alarm ended. The value ranges from 10s to 300s.
Send Email	If you enabled this function, System can send out email to alert you when alarm occurs and ends. User can set email address in Network>SMTP.
Audio linkage	Check it and the system will play alarm audio file when alarm occurs. User can set the recorded or uploaded audio file in "camera setting > audio > alarm audio".

Parameter	Function
Flash linkage	Check it and the flash will be on when alarm occurs, and the flash will be off until the end of alarm after corresponding delay.
PTZ	<ul style="list-style-type: none"> Here you can set PTZ movement when alarm occurs. Such as go to preset x when there is an alarm. The event type includes: preset, tour and pattern.
Snapshot	You need to check the box here so that system can backup motion detection snapshot file. You shall set snapshot period in Storage>Schedule.

Step 5

Click “Save” to complete the setting of motion detection.

5.3.1.2 Video Tampering

Step 1

Select “Setup > Event > Video Detection > Video Tampering” and the system will display the interface of “Video Tampering” which is shown in Figure 5-66.

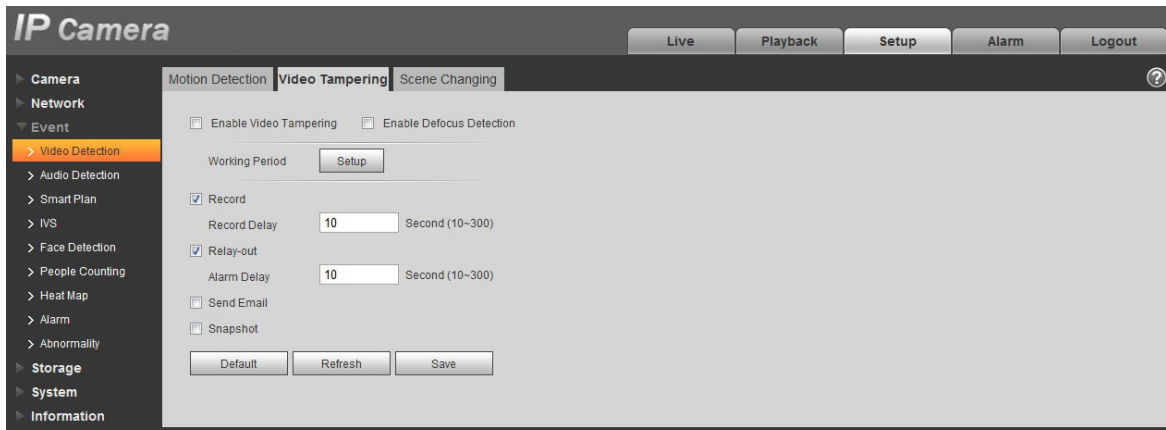

Figure 5-66

Step 2

Set the parameter of video tampering; please refer to the following sheet for more details.

Parameter	Function
Enable video tampering	You need to check the box to enable video mask detection alarm.
Enable defocus detection	You need to check the box to enable defocus detection alarm.

Parameter	Function
Working Period	<p>Note: It is to set the alarm period, it can enable alarm event only during the period range which has been set.</p> <ol style="list-style-type: none"> 1. Click "Setup" and the system will pop out the interface of "Working Period". 2. It is to set working period according to the following methods: <ul style="list-style-type: none"> ● You can input time numerical value or press the left mouse button to drag on the setup interface to set. ● There are six periods to be set every day, select the check box in front of the period, and then the period is valid. ● Select week number (it selects Sunday by default, if it selects the whole week, then it means the setup can be applied to the whole week, you can also select the check box in front of the week number to implement independent setting for some days). 3. Click "Save" to complete the setup of working period.
Record	Check it and so when alarm occurs, system will auto record. You shall set record period in Storage>Schedule and select auto record in record control interface.
Record Delay	System can delay the record for specified time after alarm ended. The value ranges from 10s to 300s.
Relay out	Enable alarm activation function. You need to select alarm output port so that system can activate corresponding alarm device when alarm occurs.
Alarm Delay	System can delay the alarm output for specified time after alarm ended. The value ranges from 10s to 300s.
Send Email	If you enabled this function, System can send out email to alert you when alarm occurs and ends. User can set email address in Network>SMTP.
Audio linkage	Check it and the system will play alarm audio file when alarm occurs. User can set the recorded or uploaded audio file in "camera setting > audio > alarm audio".
Flash linkage	Check it and the flash will be on when alarm occurs, and the flash will be off until the end of alarm after corresponding delay.
PTZ	<ul style="list-style-type: none"> ● Here you can set PTZ movement when alarm occurs. Such as go to preset x when there is an alarm. ● The event type includes: preset, tour and pattern.
Snapshot	You need to check the box here so that system can backup motion detection snapshot file. You shall set snapshot period in Storage>Schedule.

Step 3

Click "Save" to complete the setup of video tampering.

5.3.1.3 Scene Changing

Step 1

Select "Setup > Event > Video Detection > Scene Changing" and the system will display the interface of "Scene Changing" which is shown in Figure 5-67.

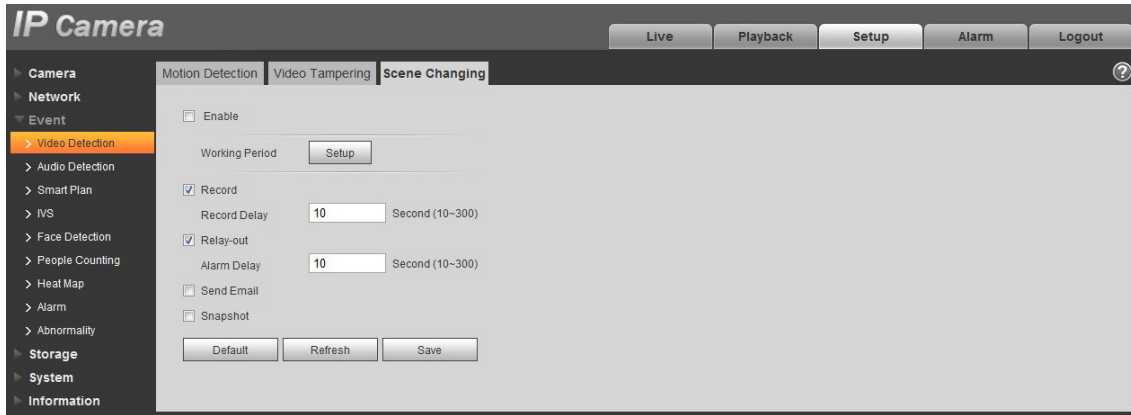

Figure 5-67

Step 2

Check “Enable” to enable the function of scene changing.

Step 3

It is to set the parameters of scene changing, please refer to the following sheet for more details.

Parameter	Function
Working Period	<p>Note: It is to set the alarm period, it can enable alarm event only during the period range which has been set.</p> <ol style="list-style-type: none"> Click “Setup” and the system will pop out the interface of “Working Period”. It is to set working period according to the following methods: <ul style="list-style-type: none"> You can input time numerical value or press the left mouse button to drag on the setup interface to set. There are six periods to be set every day, select the check box in front of the period, and then the period is valid. Select week number (it selects Sunday by default, if it selects the whole week, then it means the setup can be applied to the whole week, you can also select the check box in front of the week number to implement independent setting for some days). Click “Save” to complete the setup of working period.
Record	Check it and so when alarm occurs, system will auto record. You shall set record period in Storage>Schedule and select auto record in record control interface.
Record Delay	System can delay the record for specified time after alarm ended. The value ranges from 10s to 300s.
Relay out	Enable alarm activation function. You need to select alarm output port so that system can activate corresponding alarm device when alarm occurs.
Alarm Delay	System can delay the alarm output for specified time after alarm ended. The value ranges from 10s to 300s.
Send Email	If you enabled this function, System can send out email to alert you when alarm occurs and ends. User can set email address in Network>SMTP.

Parameter	Function
PTZ	<ul style="list-style-type: none"> ● Here you can set PTZ movement when alarm occurs. Such as go to preset x when there is an alarm. ● The event type includes: preset, tour and pattern.
Snapshot	You need to check the box here so that system can backup motion detection snapshot file. You shall set snapshot period in Storage>Schedule.

Step 4

Click “Save” to complete the setup of scene changing.

5.3.2 Audio Detection

Step 1

Select “Setup > Event > Audio Detection” and the system will display the interface of “Audio Detection” which is shown in Figure 5-68.

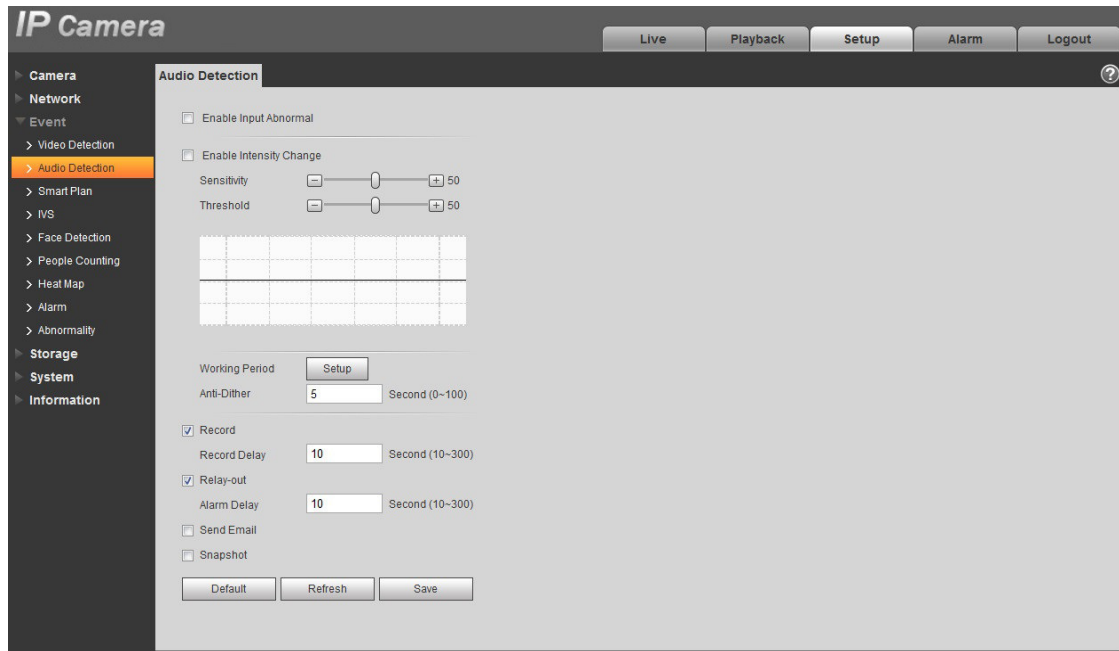

Figure 5-68

Step 2

It is to set the parameters of audio detect, please refer to the following sheet for more details.

Parameter	Function
Enable input abnormal	Select “Enable Input Abnormal” and it will trigger alarm when it detects audio input abnormality.
Enable intensity change	Select “Enable Intensity Change” and it will trigger alarm when it detects that audio intensity change exceeds the threshold.

Parameter	Function
Sensitivity	It can be judged as audio abnormality when the input volume change exceeds continuous environment volume; users need to adjust according to the actual environment test.
Threshold	It is to set the filtered environment volume intensity, if the environmental noise is too big, then the value needs to be set higher, users can adjust according to the actual environment test.
Working Period	<p>Note: It is to set the alarm period, it can enable alarm event only during the period range which has been set.</p> <ol style="list-style-type: none"> 1. Click "Setup" and the system will pop out the interface of "Working Period". 2. It is to set working period according to the following methods: <ul style="list-style-type: none"> ● You can input time numerical value or press the left mouse button to drag on the setup interface to set. ● There are six periods to be set every day, select the check box in front of the period, and then the period is valid. ● Select week number (it selects Sunday by default, if it selects the whole week, then it means the setup can be applied to the whole week, you can also select the check box in front of the week number to implement independent setting for some days). 3. Click "Save" to complete the setup of working period.
Anti-dither	System only memorizes one event during the anti-dither period. The value ranges from 0s to 100s.
Record	Check it and so when alarm occurs, system will auto record. You shall set record period in Storage>Schedule and select auto record in record control interface.
Record Delay	System can delay the record for specified time after alarm ended. The value ranges from 10s to 300s.
Relay out	Enable alarm activation function. You need to select alarm output port so that system can activate corresponding alarm device when alarm occurs.
Alarm Delay	System can delay the alarm output for specified time after alarm ended. The value ranges from 10s to 300s.
Send Email	If you enabled this function, System can send out email to alert you when alarm occurs and ends. User can set email address in Network>SMTP.
PTZ	<ul style="list-style-type: none"> ● Here you can set PTZ movement when alarm occurs. Such as go to preset x when there is an alarm. ● The event type includes: preset, tour and pattern.
Snapshot	You need to check the box here so that system can backup motion detector snapshot file. You shall set snapshot period in Storage>Schedule.

Step 3

Click "Save" to complete the setup of audio detection.

5.3.3 Smart Plan

Smart plan is the master switch for intelligent analysis such as “Face Detection”, “Heat Map”, “IVS”, “People Counting” and so on, the corresponding intelligent functions can be valid after smart plan is enabled.

Step 1

Select “Setup > Event > Smart Plan”. The system will display the interface of “Smart Plan”, which is shown in Figure 5-69.



Figure 5-69

Step 2

Click “Save” to complete the config of smart plan.

5.3.4 Intelligence Behavior Analytics

The basic requirements of scene selection

- The total proportion of the target shall not exceed 10% of the image.
- The target size in the image can't be less than 10 pixel × 10 pixel, the size of abandoned target can't be less than 15 pixel × 15 pixel (CIF image); The height and width of the target can't exceed 1/3 of the image; it is recommended that the target height is about 10% of the image height.
- The difference of brightness value between target and background can't be less than 10 gray levels.
- Make sure the target appears at least over 2 seconds continuously in the field; the movement distance has to be bigger than the width of the target itself and makes sure it is no less than 15 pixels (CIF image).
- Try to lower the complexity of the monitoring scene analysis if it is possible; it is not advised to use IVS functions in the environment where the targets are dense and light change is very frequent.
- Try to keep away from the areas such as glass, ground reflected light, water surface, branch, shadow, mosquito disturbance and etc.; try to keep away from the backlight scene to avoid direct light.

5.3.4.1 IVS

5.3.4.1.1 Tripwire

It will trigger alarm when the target crosses the warning line according to the movement direction which has been set.

It needs some time from when the target appears to when the target is confirmed, so it has to leave some space on both sides of the warning line when setting the warning line, please do not set the warning line near the obstructions.

Application scene: it can be applied to the scene with sparse target and there is barely any blocks between the targets, such as the unmanned perimeter defense.

Step 1

Select “Setup > Event > IVS > IVS” and the system will display the interface of “IVS”.

Step 2

Click “+” to set rule name and select the rule type as “Tripwire” which is shown in Figure 5-70.

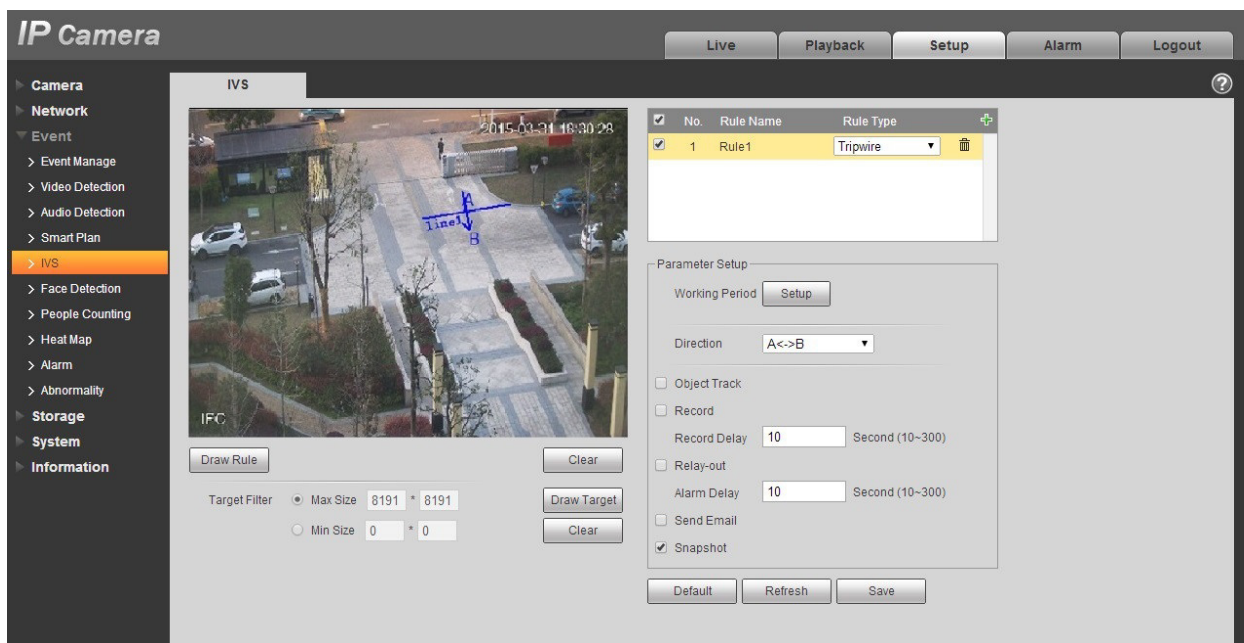

Figure 5-70

Step 3

Click “Draw Rule” to draw tripwire in the monitoring scene, click the right mouse button to complete tripwire setting.

Step 4

Click “Draw Target” to draw the size model of filtered target in the video image.

Step 5

It is to set the parameters of tripwire, please refer to the following sheet for more details.

Parameter	Function
Object tracking	Select "Object tracking" to enable the function, refer to "2.4 Video Window Adjustment" for more details. Note: The function is only supported by some models.
Working Period	Note: It is to set the alarm period, it can enable alarm event only during the period range which has been set. 1. Click "Setup" and the system will pop out the interface of "Working Period". 2. It is to set working period according to the following methods: <ul style="list-style-type: none"> ● You can input time numerical value or press the left mouse button to drag on the setup interface to set. ● There are six periods to be set every day, select the check box in front of the period, and then the period is valid. ● Select week number (it selects Sunday by default, if it selects the whole week, then it means the setup can be applied to the whole week, you can also select the check box in front of the week number to implement independent setting for some days). 3. Click "Save" to complete the setup of working period.
Direction	It is to set the direction of tripwire, you can select A->B、 B->A、 A<->B.
Object Track	Select "Object Track" and it will enable the function of object track; when the moving object triggers rule and generates alarm, it will select the display mode of object track such as 1P+3 or 1P+5 in the preview interface, the scene of tracking window will follow the moving object till the object leaves the view range of the camera. Please refer to "2.4.8 Fisheye/Trigger Track" for more details.
Record	Check it and so when alarm occurs, system will auto record.
Record Delay	System can delay the record for specified time after alarm ended.
Relay out	Enable alarm activation function. You need to select alarm output port so that system can activate corresponding alarm device when alarm occurs.
Alarm Delay	System can delay the alarm output for specified time after alarm ended.
Send Email	If you enabled this function, System can send out email to alert you when alarm occurs and ends. User can set email address in Network>SMTP.
Snapshot	Select "Snapshot" and the system will auto trigger alarm and snapshot when alarm occurs.

Step 5

Click "Save" to complete the setup of tripwire.

5.3.4.2 Intrusion

Intrusion includes cross and appears.

- Cross means that it will trigger alarm when the target enters or exits the area.
- Appears means that it will trigger alarm when the target appears in the area.
- As for the report interval of the IVS function in the area, the system will trigger an alarm if it detects same event happened during the interval; the alarm counter will become zero if there is no same event happened in the interval.

It needs to leave some space for target movement for the area periphery if it is to detect enter & exit event, which is similar to the warning line.

Application scene; it can be applied to the scene where the target is sparse and there is barely any obstruction between the targets, such as the unmanned perimeter defense.

Step 1

Select “Setup > Event > IVS > IVS” and the system will display the interface of “IVS”.

Step 2

Click “+” to set rule name, select the rule type as “Intrusion” which is shown in Figure 5-71.

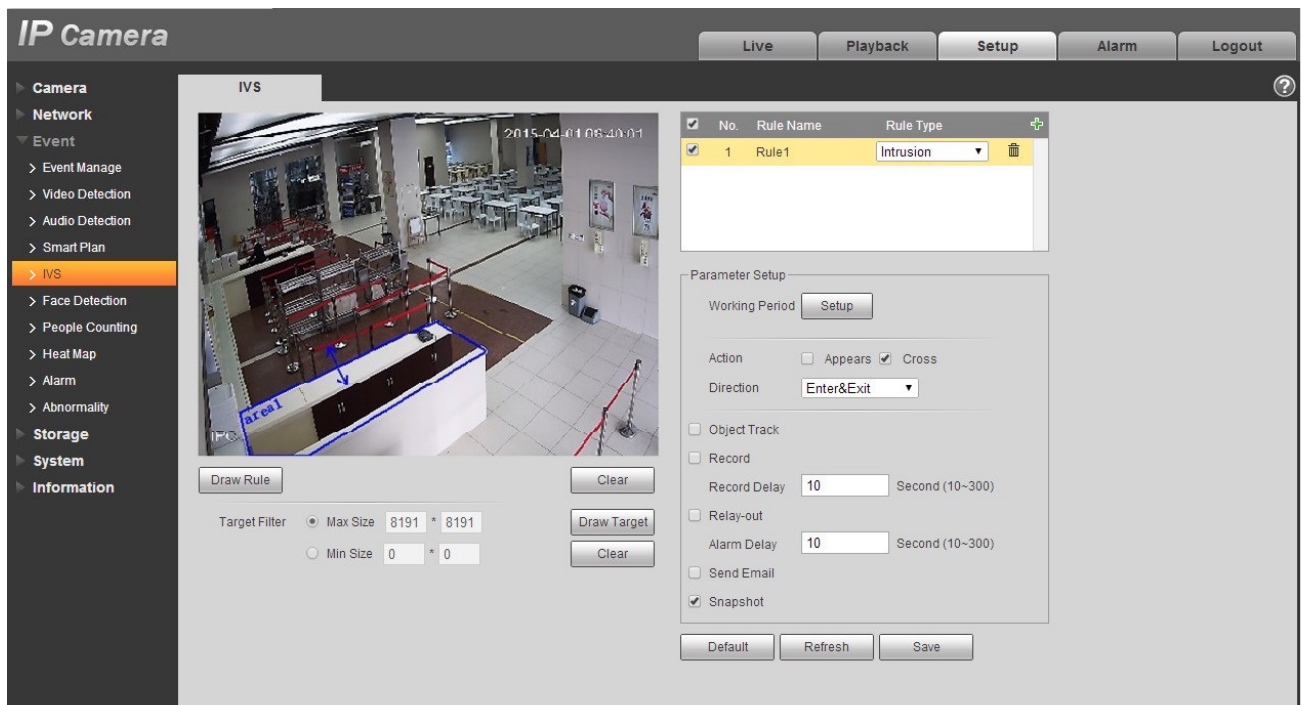

Figure 5-71

Step 3

Click “Draw Rule” to draw an area in the monitoring image.

Step 4

Click “Draw Target” to draw the size model of filtered target in the video image.

Step 5

It is to set the parameters of intrusion, please refer the following sheet for more details.

Parameter	Function
Object tracking	Select "Object tracking" to enable the function, refer to "2.4 Video Window Adjustment" for more details. Note: The function is only supported by some models.
Working Period	Note: It is to set the alarm period, it can enable alarm event only during the period range which has been set. 1. Click "Setup" and the system will pop out the interface of "Working Period". 2. It is to set working period according to the following methods: <ul style="list-style-type: none"> ● You can input time numerical value or press the left mouse button to drag on the setup interface to set. ● There are six periods to be set every day, select the check box in front of the period, and then the period is valid. ● Select week number (it selects Sunday by default, if it selects the whole week, then it means the setup can be applied to the whole week, you can also select the check box in front of the week number to implement independent setting for some days). 3. Click "Save" to complete the setup of working period.
Action	It is to set the action of intrusion, you can select appears and cross.
Direction	It is to set the direction of intrusion, you can select enter, exit and enter&exit.
Object Track	Select "Object Track" and it will enable the function of object track; when the moving object triggers rule and generates alarm, it will select the display mode of object track such as 1P+3 or 1P+5 in the preview interface, the scene of tracking window will follow the moving object till the object leaves the view range of the camera. Please refer to "2.4.8 Fisheye/Trigger Track" for more details.
Record	Check it and so when alarm occurs, system will auto record.
Record Delay	System can delay the record for specified time after alarm ended.
Relay out	Enable alarm activation function. You need to select alarm output port so that system can activate corresponding alarm device when alarm occurs.
Alarm Delay	System can delay the alarm output for specified time after alarm ended.
Send Email	If you enabled this function, System can send out email to alert you when alarm occurs and ends. User can set email address in Network>SMTP.
Snapshot	Select "Snapshot" and the system will auto trigger alarm and snapshot when alarm occurs.

Step 5

Click "Save" to complete the setup of intrusion.

5.3.4.3 Abandoned Object

Abandoned object means the system will trigger alarm if the abandoned object in the monitoring scene exceeds the time which has been set by the users.

Abandoned object and missing object can be confusing in a situation where both foreground and background are complicated.

It also triggers alarm as abandoned object if there is pedestrian or vehicle staying still for too long. In order to filter this kind of alarm, generally the abandoned object is smaller than people and vehicle; therefore it can filter the people and vehicle via setting size. Besides, it can avoid the false alarm caused by short stay of people via extending alarm time properly.

Application scene: It can be applied to the scene where the target is sparse and there is no obvious and frequent light change. False alarm will be increased in the scene with high target density and frequent blocking; false alarm will be increased in the scene where there are more people staying. As for the detection area, try to make it simple, the function is not suitable for the area which is too complicated.

Step 1

Select “Setup > Event > IVS > IVS” and the system will display the interface of “IVS”.

Step 2

Click “+” to set rule name, select the rule type as “Abandoned Object” which is shown in Figure 5-72.

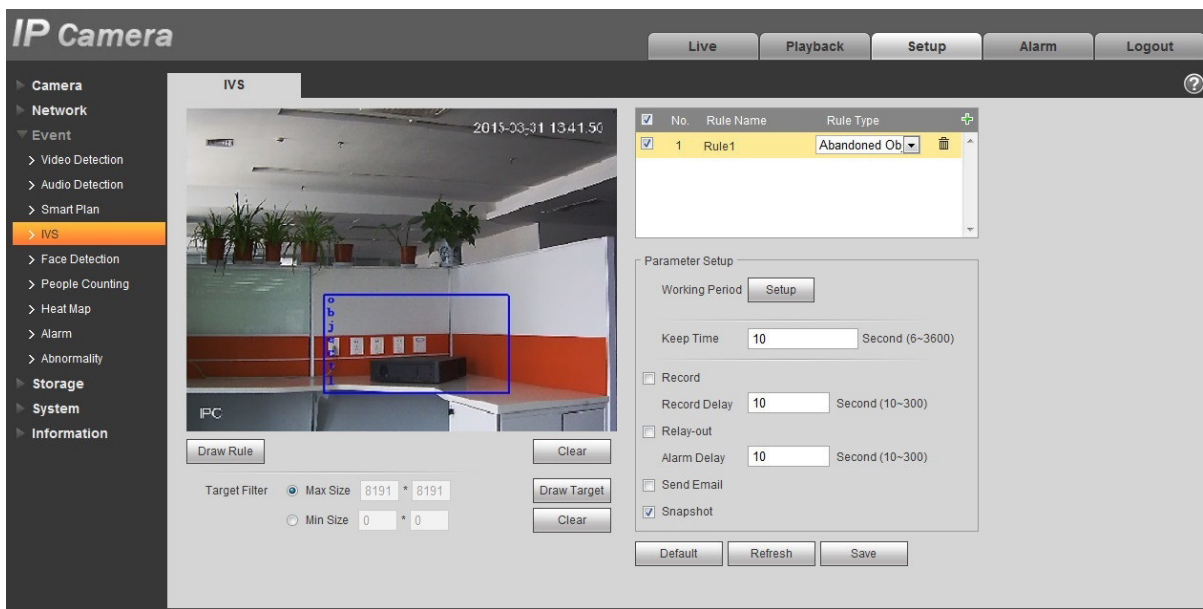

Figure 5-72

Step 3

Click “Draw Rule” to draw an area in the monitoring area.

Step 4

Click “Draw Target” to draw the size model of filtered target in the video image.

Step 5

It is to set the parameter of abandoned object, please refer to the following sheet for more details.

Parameter	Function
Working Period	<p>Note: It is to set the alarm period, it can enable alarm event only during the period range which has been set.</p> <ol style="list-style-type: none"> 1. Click "Setup" and the system will pop out the interface of "Working Period". 2. It is to set working period according to the following methods: <ul style="list-style-type: none"> ● You can input time numerical value or press the left mouse button to drag on the setup interface to set. ● There are six periods to be set every day, select the check box in front of the period, and then the period is valid. ● Select week number (it selects Sunday by default, if it selects the whole week, then it means the setup can be applied to the whole week, you can also select the check box in front of the week number to implement independent setting for some days). 3. Click "Save" to complete the setup of working period.
Keep time	It is to set the shortest time from when the object is abandoned to when it triggers alarm.
Record	Check it and so when alarm occurs, system will auto record.
Record Delay	System can delay the record for specified time after alarm ended.
Relay out	Enable alarm activation function. You need to select alarm output port so that system can activate corresponding alarm device when alarm occurs.
Alarm Delay	System can delay the alarm output for specified time after alarm ended.
Send Email	If you enabled this function, System can send out email to alert you when alarm occurs and ends. User can set email address in Network>SMTP.
Snapshot	Select "Snapshot" and the system will auto trigger alarm and snapshot when alarm occurs.

Step 5

Click "Save" to complete the setup of abandoned object.

5.3.4.4 Missing Object

Missing object means the system will trigger alarm if it exceeds certain amount of time after the target is taken away from the original scene.

The system can make statistics of the still areas in the foreground area and distinguish if it is missing object or abandoned object according to the similarity between foreground and background, it will trigger alarm when it exceeds the time which is set by users.

Because the system distinguishes abandoned object from missing object according to the similarity of foreground and background, it may cause error between abandoned object and missing object in a situation where both foreground and background are complicated.

Application scene: it can be applied to the scene where the target is sparse and there is no obvious and frequent light change. False alarm will be increased in the scene where the target density is high and there is frequent obstruction; the false alarm will be increased in the scene where there are more people staying. As for the detection area, try to make it simple, the function is not suitable for the area which is too complicated.

Step 1

Select “Setup > Event > IVS > IVS” and the system will display the interface of “IVS”.

Step 2

Click “+” to set rule name and select rule type as “Missing Object”, which is shown in Figure 5-73.

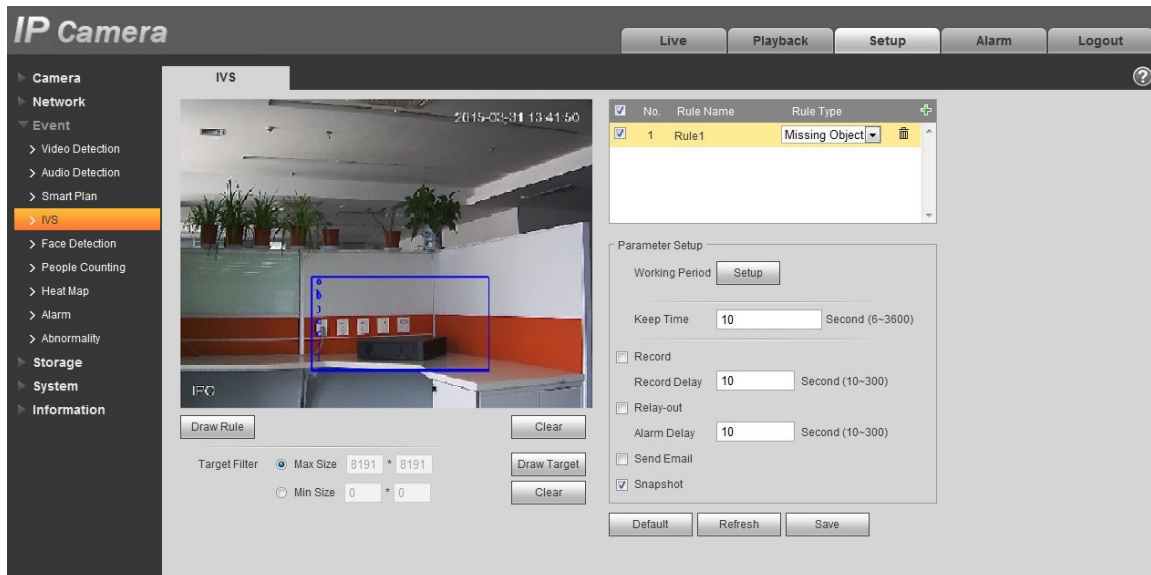

Figure 5-73

Step 3

Click “Draw Rule” to draw an area in the monitoring scene.

Step 4

Click “Draw Target” to draw the size model of filtered target in the video image.

Step 5

It is to set the parameters of missing object, please refer to the following sheet for more details.

Parameter	Function
Working Period	<p>Note: It is to set the alarm period, it can enable alarm event only during the period range which has been set.</p> <ol style="list-style-type: none"> 1. Click "Setup" and the system will pop out the interface of "Working Period". 2. It is to set working period according to the following methods: <ul style="list-style-type: none"> ● You can input time numerical value or press the left mouse button to drag on the setup interface to set. ● There are six periods to be set every day, select the check box in front of the period, and then the period is valid. ● Select week number (it selects Sunday by default, if it selects the whole week, then it means the setup can be applied to the whole week, you can also select the check box in front of the week number to implement independent setting for some days). 3. Click "Save" to complete the setup of working period.
Keep time	It is to set the shortest time from when the object is missing to when it triggers alarm.
Record	Check it and so when alarm occurs, system will auto record.
Record Delay	System can delay the record for specified time after alarm ended.
Relay out	Enable alarm activation function. You need to select alarm output port so that system can activate corresponding alarm device when alarm occurs.
Alarm Delay	System can delay the alarm output for specified time after alarm ended.
Send Email	If you enabled this function, System can send out email to alert you when alarm occurs and ends. User can set email address in Network>SMTP.
Snapshot	Select "Snapshot" and the system will auto trigger alarm and snapshot when alarm occurs.

Step 5

Click "Save" to complete the setup of missing object.

5.3.5 Face Detection

Step 1

Select "Setup > Event > Face Detection" and the system will display the interface of "Face Detection", which is shown in Figure 5-74.

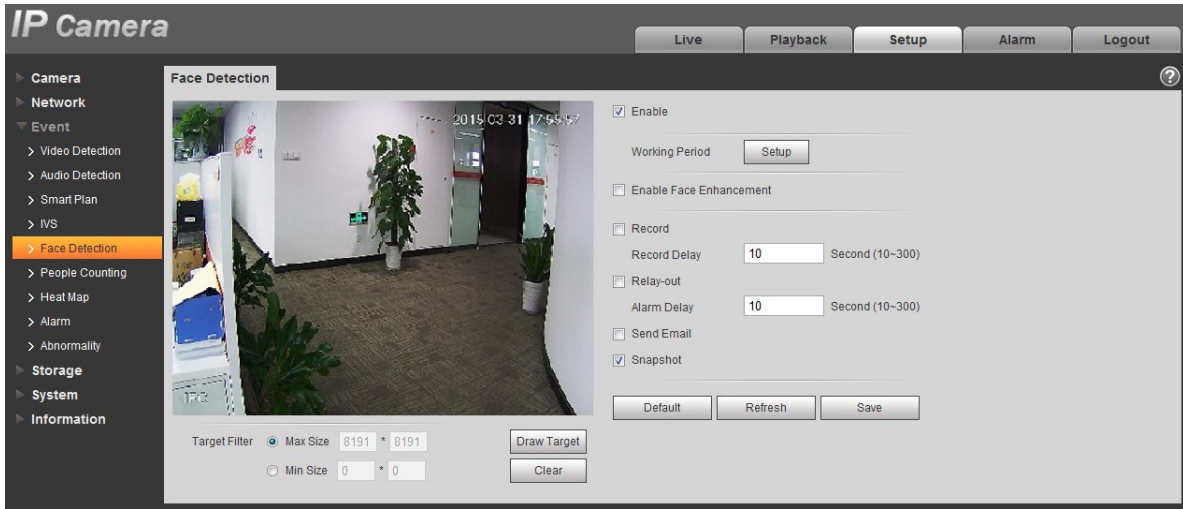

Figure 5-74

Step 2

Select “Enable” to enable face detection function.

Step 3

Click “Draw Target” to draw the size model of target filter in the video image.

Step 4

It is to set the parameters of face detection, please refer to the following sheet for more details.

Parameter	Function
Working Period	<p>Note: It is to set the alarm period, it can enable alarm event only during the period range which has been set.</p> <ol style="list-style-type: none"> Click “Setup” and the system will pop out the interface of “Working Period”. It is to set working period according to the following methods: <ul style="list-style-type: none"> You can input time numerical value or press the left mouse button to drag on the setup interface to set. There are six periods to be set every day, select the check box in front of the period, and then the period is valid. Select week number (it selects Sunday by default, if it selects the whole week, then it means the setup can be applied to the whole week, you can also select the check box in front of the week number to implement independent setting for some days). Click “Save” to complete the setup of working period.
Enable Face Enhancement	Select “Enable Face Enhancement” and it will guarantee that the face is clear by priority when the stream is set very low.
Record	Check it and so when alarm occurs, system will auto record.
Record Delay	System can delay the record for specified time after alarm ended.

Parameter	Function
Relay out	Enable alarm activation function. You need to select alarm output port so that system can activate corresponding alarm device when alarm occurs.
Alarm Delay	System can delay the alarm output for specified time after alarm ended.
Send Email	If you enabled this function, System can send out email to alert you when alarm occurs and ends. User can set email address in Network>SMTP.
Snapshot	Select "Snapshot" and the system will auto trigger alarm and snapshot when alarm occurs.

Step 5

Click "Save" to complete the setup of face detection.

5.3.6 People Counting

5.3.6.1 People Counting

Step 1

Select "Setup > Event > People Counting > People Counting" and the system will display the interface of "Entrance/Exit", which is shown in Figure 5-75.

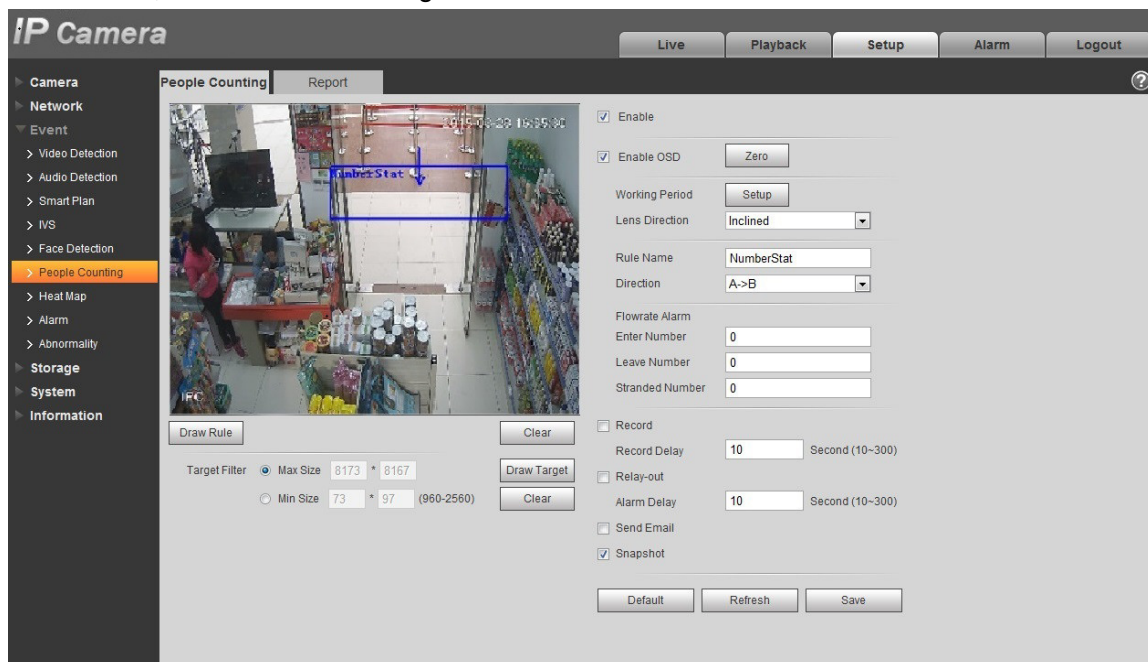

Figure 5-75

Step 2

Select "Enable" to enable statistics function of entrance and exit.

Step 3

Click "Draw Rule" to draw an area in the monitoring image.

Step 4

Click “Draw Target” to draw the size model of filtered target in the video image.

Step 5

It is to set the parameters of entrance and exit, please refer to the following sheet for more details.

Parameter	Function
Enable OSD	Select “Enable OSD” and it will display the people number statistics of entrance and exit in the monitoring image.
Working Period	<p>Note: It is to set the alarm period, it can enable alarm event only during the period range which has been set.</p> <ol style="list-style-type: none"> Click “Setup” and the system will pop out the interface of “Working Period”. It is to set working period according to the following methods: <ul style="list-style-type: none"> You can input time numerical value or press the left mouse button to drag on the setup interface to set. There are six periods to be set every day, select the check box in front of the period, and then the period is valid. Select week number (it selects Sunday by default, if it selects the whole week, then it means the setup can be applied to the whole week, you can also select the check box in front of the week number to implement independent setting for some days). Click “Save” to complete the setup of working period.
Installation Mode	It is to select wall mount if there is an angle between device lens and horizontal surface, select ceiling if the device lens face downward vertically.
Rule Name	It is to set the name of rule.
Direction	It is to select the direction of entrance and exit statistics; A->B or B->A, the arrow direction always means the entrance direction.
Flowrate Alarm	It is to set the enter number, leave number, stranded number; it will trigger alarm when it exceeds the limited number.
Record	Check it and so when alarm occurs, system will auto record.
Record Delay	System can delay the record for specified time after alarm ended.
Relay out	Enable alarm activation function. You need to select alarm output port so that system can activate corresponding alarm device when alarm occurs.
Alarm Delay	System can delay the alarm output for specified time after alarm ended.
Send Email	If you enabled this function, System can send out email to alert you when alarm occurs and ends. User can set email address in Network>SMTP.
Snapshot	Select “Snapshot” and the system will auto trigger alarm and snapshot when alarm occurs.

Step 6

Click “Save” to complete the setup of people counting.

5.3.6.2 Report

It is to generate a form of report according to the number statistics.

Step 1

Select “Setup > Event > People Counting > Report” and the system will display the interface of “Report”, which is shown in Figure 5-76.

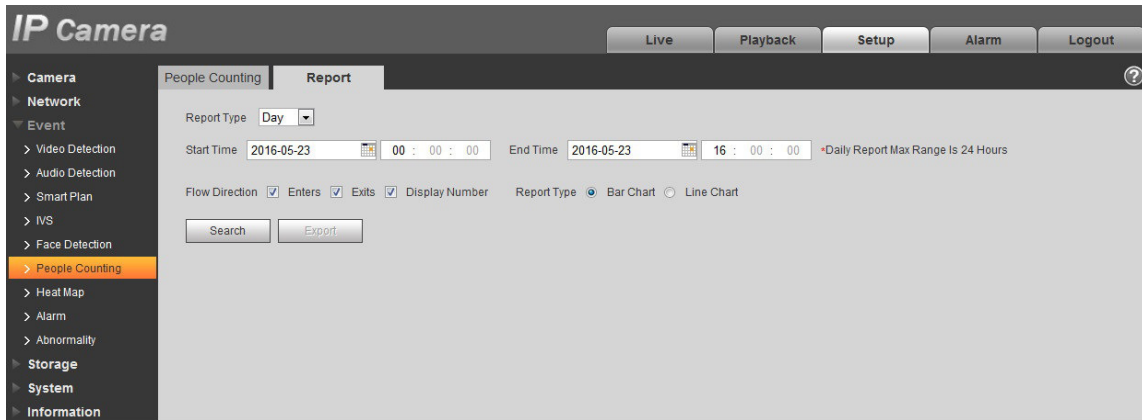

Figure 5-76

Step 2

It is to set search condition, please refer to the following sheet for more details.

Parameter	Note
Report Type	Can select day report, month report and year report; also can select bar chart or line chart to display the report.
Time	It can set the begin /end time within the range of statistics time.
Flow Direction	It can select enter, leave and display number; the data of checked item can be displayed in the report.
Search	Search flow statistics data according to the setting to form report.
Export	Export the saved report.

Step 3

Click “Search” to complete report statistics, click “Export” to export the report.

5.3.7 Heat Map

5.3.7.1 Heat Map

It is the density statistics of moving object that can generate report, the color range is from blue to red, blue means the min heat value and red means the max heat value.

Mirroring, view angle change and heat map original data will be cleared.

Step 1

Select “Setup > Event > Heat Map > Heat Map” and the system will display the interface of “Heat Map”, which is shown in Figure 5-77.

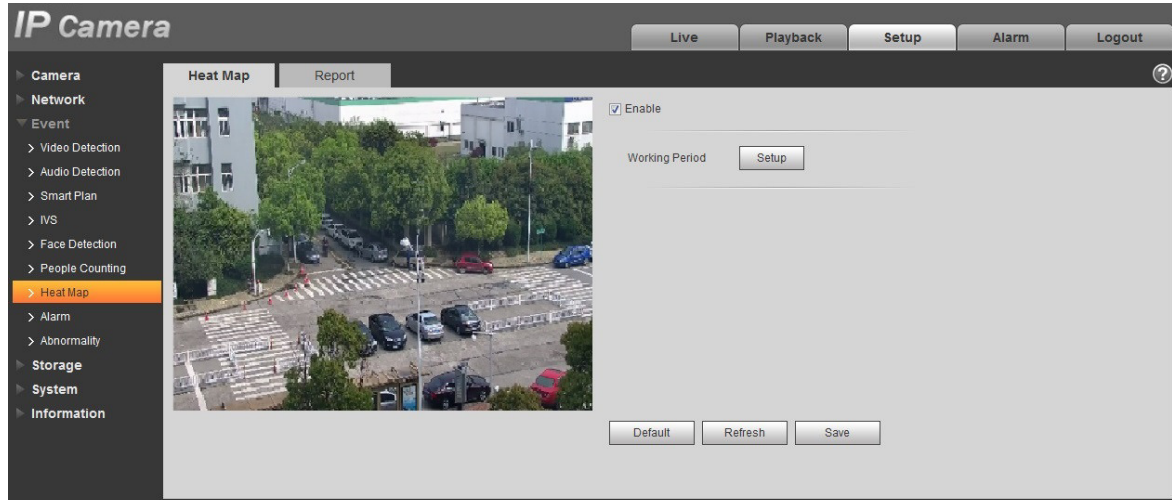

Figure 5-77

Step 2

Select “Enable” to enable heat map function.

Step 3

It is to set the working period.

1. Click “Setup” and the system will display the interface of “Working Period”, which is shown in Figure 5-78.

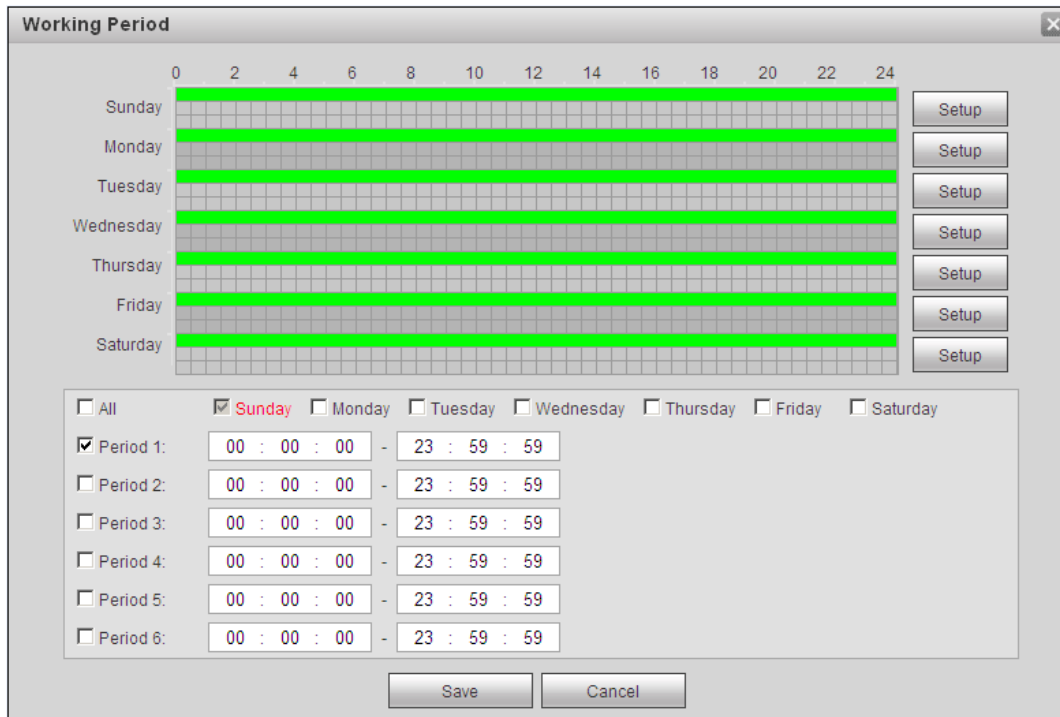

Figure 5-78

2. It is to set working period according to the following methods:
 - You can input time numerical value or press the left mouse button to drag on the setup interface to set.
 - There are six periods to be set every day, select the check box in front of the period, and then the period is valid.
 - Select week number (it selects Sunday by default, if it selects the whole week, then it means the setup can be applied to the whole week, you can also select the check box in front of the week number to implement independent setting for some days).
3. Click “Save” to complete the setup of working period.

Step 4

Click “Save” to complete the setup of heat map.

5.3.7.2 Report

It is to generate the form of report according to the heat map data.

Step 1

Select “Setup > Event > Heat Map > Report” and the system will display the interface of “Report”, which is shown in Figure 5-79.

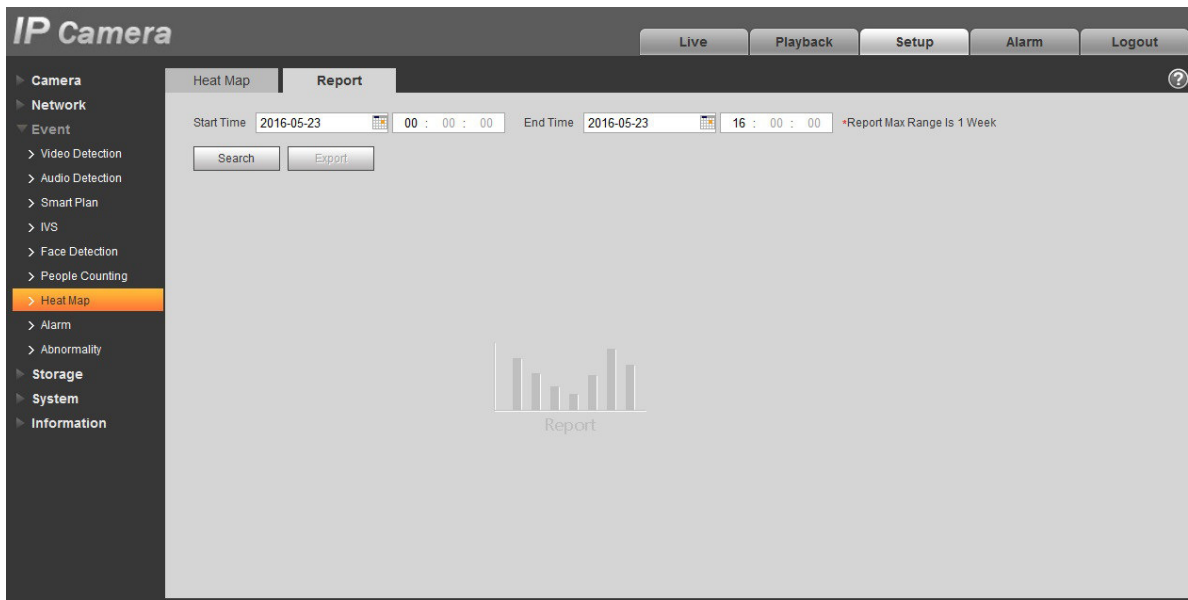

Figure 5-79

Step 2

It is to set begin time and end time.

Step 3

Click “Search” to complete report statistics, click “Export” to export the statistics report.

5.3.8 Alarm

Please note some series products do not support this function.

5.3.2.1 PIR alarm

The alarm activation interface PIR alarm is shown as in figure 5-80.

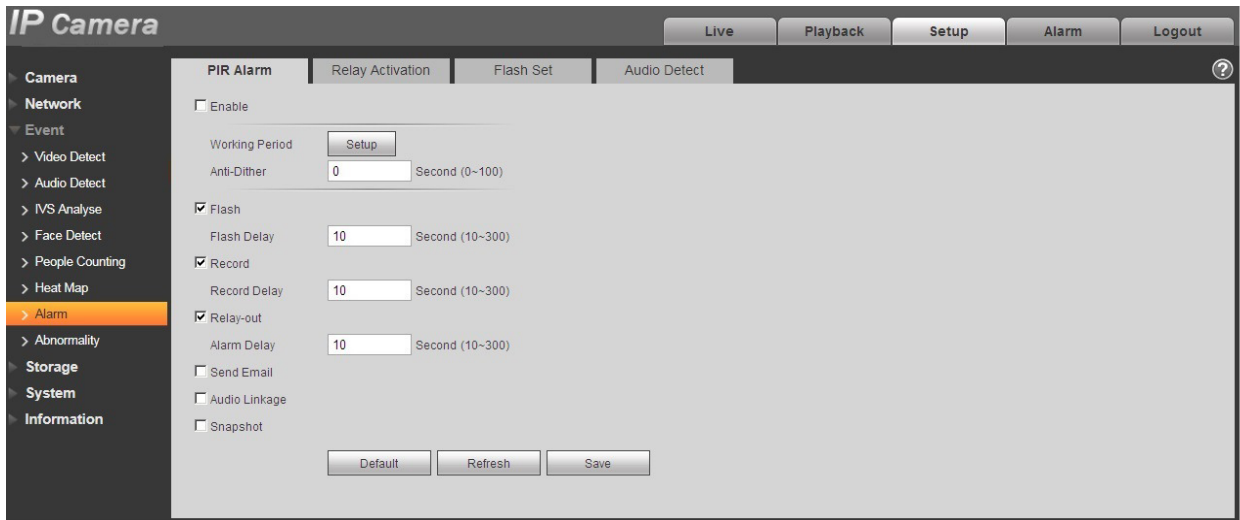

Figure 5-80

Please refer to the following sheet for detailed information.

Parameter	Function
Enable	After enabled, relay activation will work. Check it and enable the PIR alarm.
Working period	<ul style="list-style-type: none"> ● This function becomes activated in the specified periods. ● There are six periods in one day. Please draw a circle to enable corresponding period. ● Select date. If you do not select, current setup applies to today only. You can select all week column to apply to the whole week. ● Click OK button, system goes back to motion detection interface; please click save button to exit. Note: User can set via dragging mouse while not releasing left mouse.
Anti-dither	System only memorizes one event during the anti-dither period. The value ranges from 0s to 100s.
Flash	After enabling, the system will automatically turn on the flash when alarm occurs.
Flash Delay	<ul style="list-style-type: none"> • The flash will be off with a period of time delay when the alarm linkage is over. • Time is calculated by unit of second and ranges from 10s~300s.
Record	System auto activates motion detection channel to record once alarm occurs (working with motion detection function).
Record Delay	System can delay the record for specified time after alarm ended. The value ranges from 10s to 300s.

Parameter	Function
Relay out	Enable alarm activation function. You need to select alarm output port so that system can activate corresponding alarm device when alarm occurs.
Alarm delay	System can delay the alarm output for specified time after alarm ended. The value ranges from 10s to 300s.
Send Email	After this function is enabled, system can send out email to alert you when alarm occurs and ends.
Audio Linkage	Check it and the system will play alarm audio file when alarm occurs. Users can set recorded audio file in “Camera Setting > Audio > Alarm Audio”.
Snapshot	After you enabled snapshot, the system will automatically snapshot if alarm occurs.

5.3.8.1 Alarm Linkage

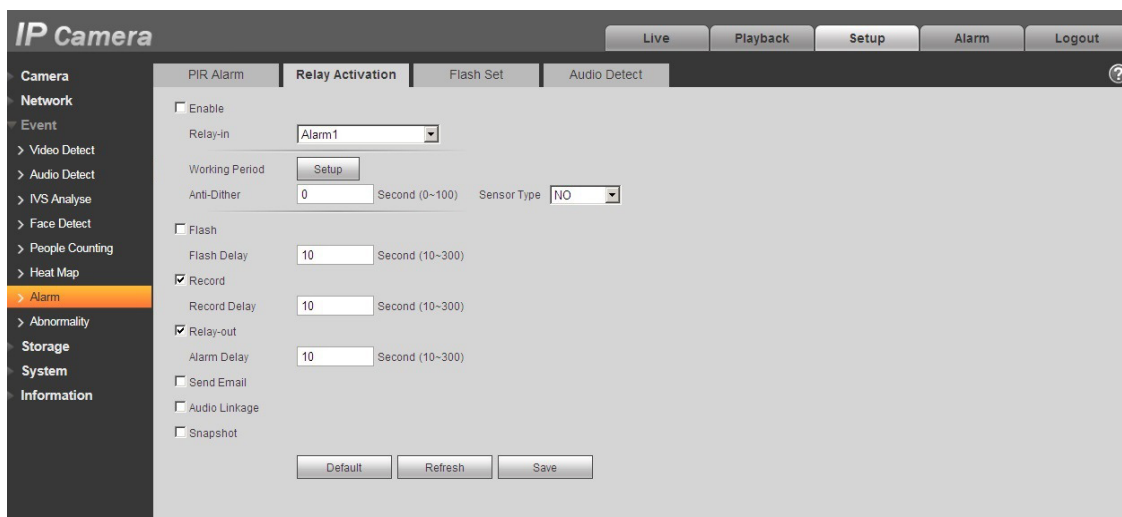

Figure 5-81

Parameter	Function
Enable	Check it and enable the alarm linkage.
Relay-in	The default alarm 1, some products can choose alarm 2.
Sensor Type	Two types of sensor which are normally open (NO) and normally closed (NC), switch from normally open to normally closed, open the alarm. Switch from normally closed to normally open, shut the alarm.

Parameter	Function
PTZ	Check it and set PTZ movement when alarm occurs. Such as go to preset x when there is an alarm. The event type includes: preset, tour and pattern and so on.

5.3.8.2 Flash Set

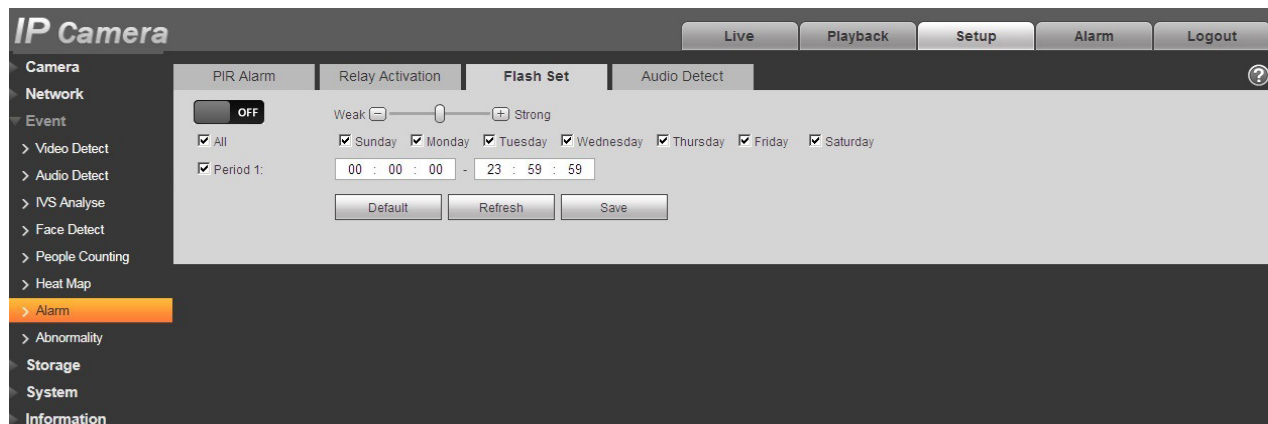

Figure 5-82

Parameter	Function
ON/OFF	ON means flash is on; OFF means flash is off.
Weak-strong bar	Via dragging this bar to adjust flash brightness.
All	Check and it means the day flash works.
Period	Period that flash is on.

5.3.8.3 Audio detection

Note: Audio detection won't work when "Talk" is enabled on the preview interface.

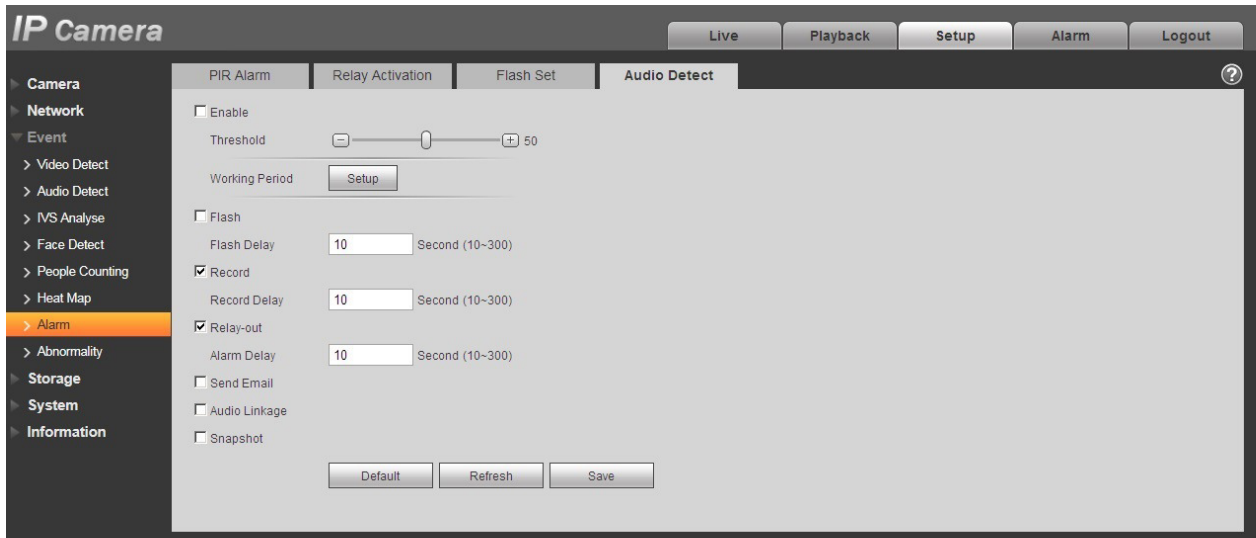

Figure 5-83

parameter	Function
Enable	Check it and enable audio detection.
Threshold	It will trigger alarm and set up a series of linkage when volume exceeds the set threshold.

5.3.9 Abnormity

Abnormity includes No SD Card, Capacity Warning, SD Card Error, Disconnection, IP Conflict and Unauthorized Access.

Note:

Only device with SD card function has these three statuses: No SD card, capacity warning, and SD card error. Device without SD card function does not have the above three statuses. See Figure 5-84 to Figure 5-86.

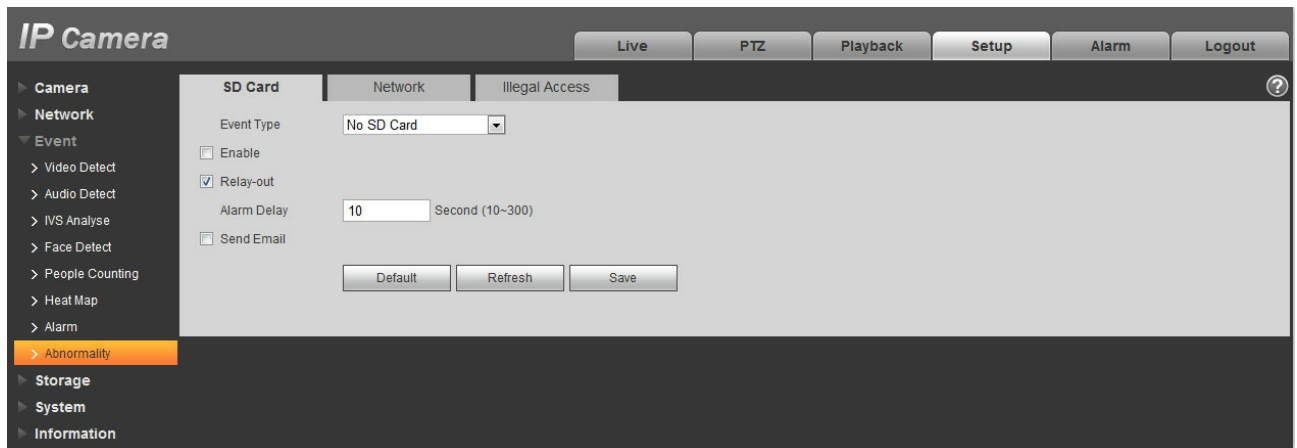

Figure 5-84

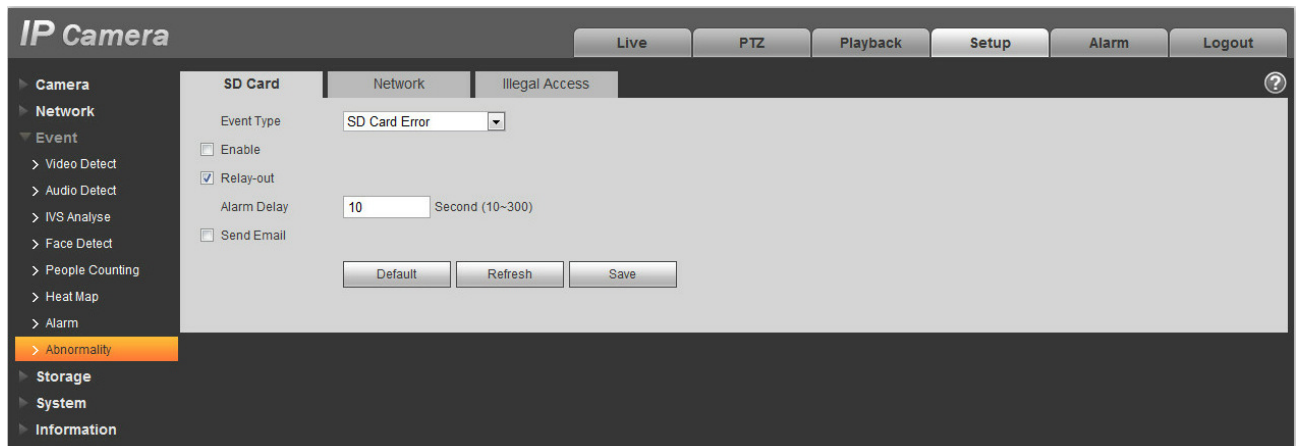

Figure 5-85

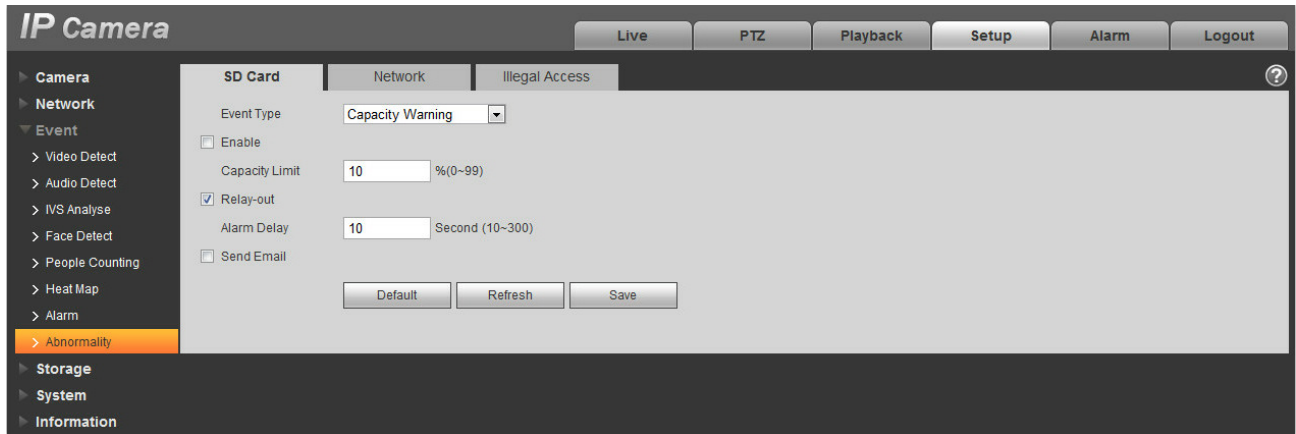

Figure 5-86

Please refer to the following sheet for detailed information.

Parameter	Function
Enable	Check to alarm when SD card is abnormal.
Relay-out	Check to enable relay-out alarm.
Relay out delay	The alarm output can delay for the specified time after alarm stops. The value ranges from 10s to 300s. Note: No SD card, capacity warning, SD card error, relay-out delay all start from alarm occurs.
Send email	After you enabled this function, the system can send out email to alarm the specified user. This function is invalid when network is offline or IP conflict occurs.
SD Card Capacity Limit	User can set SD card capacity that is left free. When SD card space left is smaller than this limit, alarm occurs.

When device is offline or IP conflicts, the abnormal alarm is similar with case of SD card error.

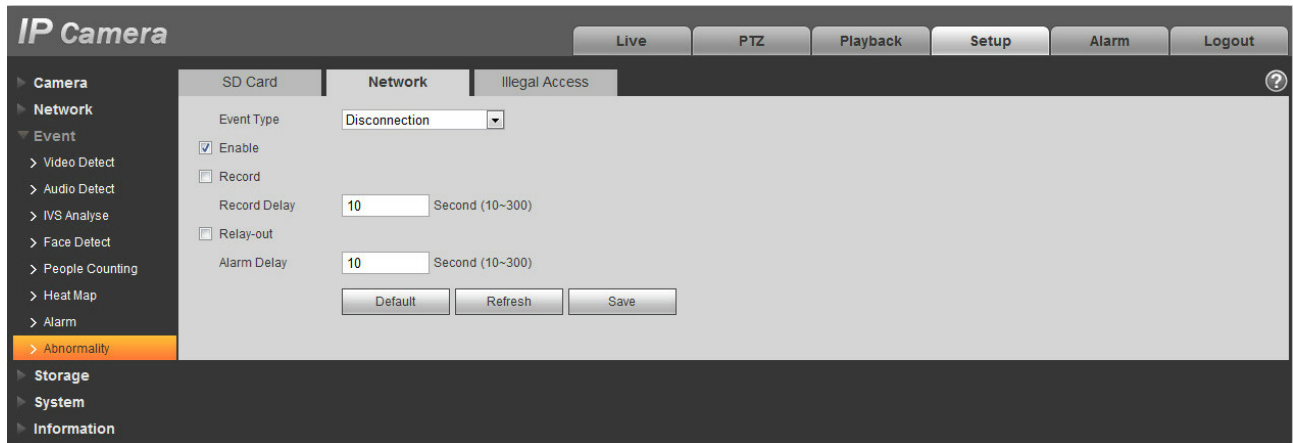

Figure 5-87

When login password keep been wrong for a few times, unauthorized access alarm occurs. This operation is similar to SD card error. Allow login error times as when it exceeds this limit, user account will be locked.



Figure 5-88

5.4 Storage Management

5.4.1 Schedule

Before schedule setup, user must set record mode is auto or manual.

Note:

If record mode in record control is off, then device will not snapshot according to schedule.

5.4.1.1 Record Schedule

Record schedule steps:

Step 1. Click on Record Schedule, see Figure 5-89.

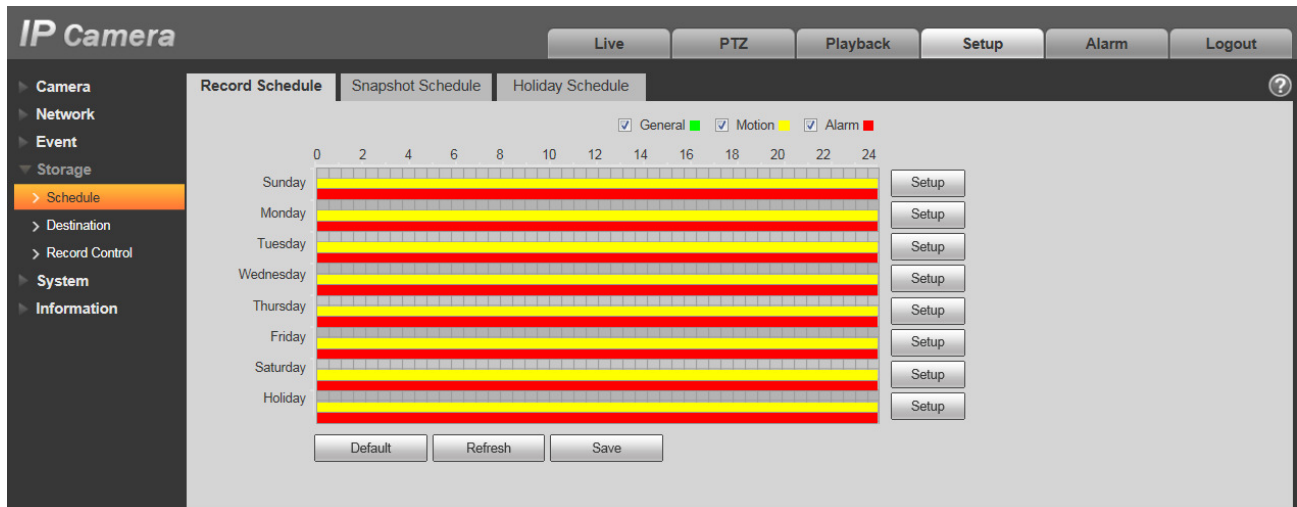

Figure 5-89

Step 2. From Monday to Sunday select record time, click on setup on the right, see Figure 5-90.

- Set period according to actual need. There are six periods available each day.
- By checking or unchecking, you can add or delete three types of record schedule: General, Motion, and Alarm.

Note:

Period setup can be done by dragging in record schedule interface while not releasing left mouse.

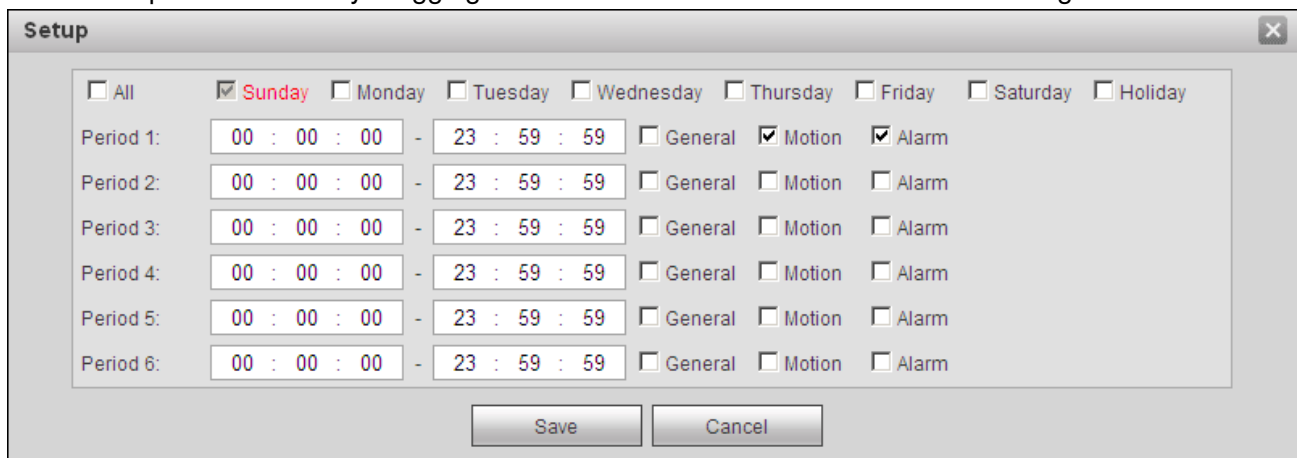

Figure 5-90

Step 3. Click on OK, return to record schedule interface. See Figure 5-91.

- Green color stands for the general record/snapshot.
- Yellow color stands for the motion detect record/snapshot.
- Red color stands for the alarm record/snapshot.

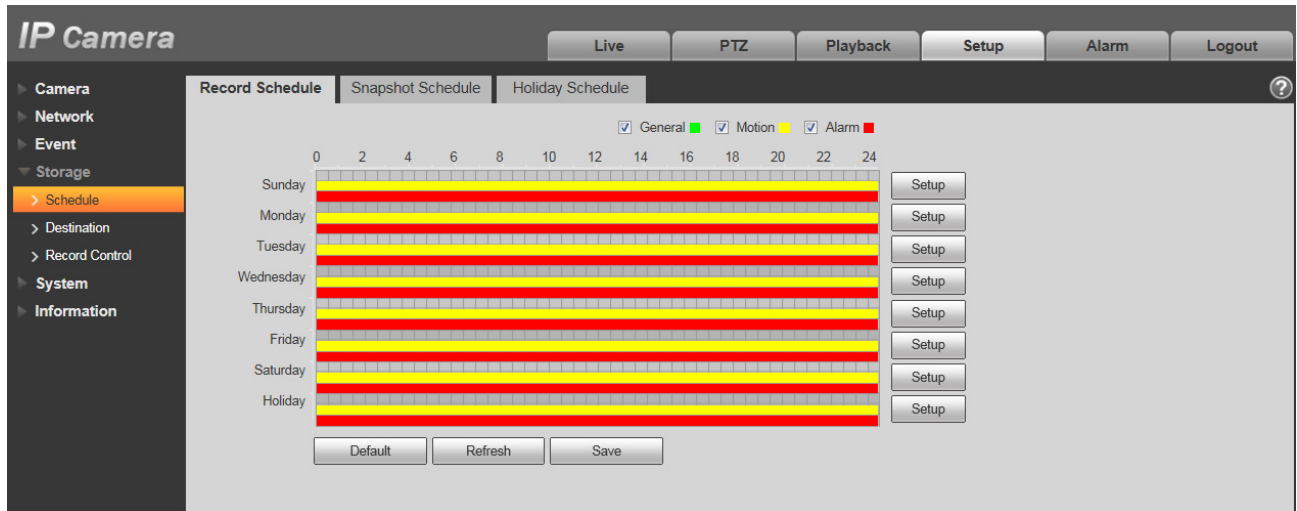

Figure 5-91

Step 4. In record schedule interface, click on OK. System prompts it is successfully saved.

5.4.1.2 Snapshot Schedule

Snapshot setup as:

Step 1. Click on Snapshot Schedule tab, see Figure 5-92.

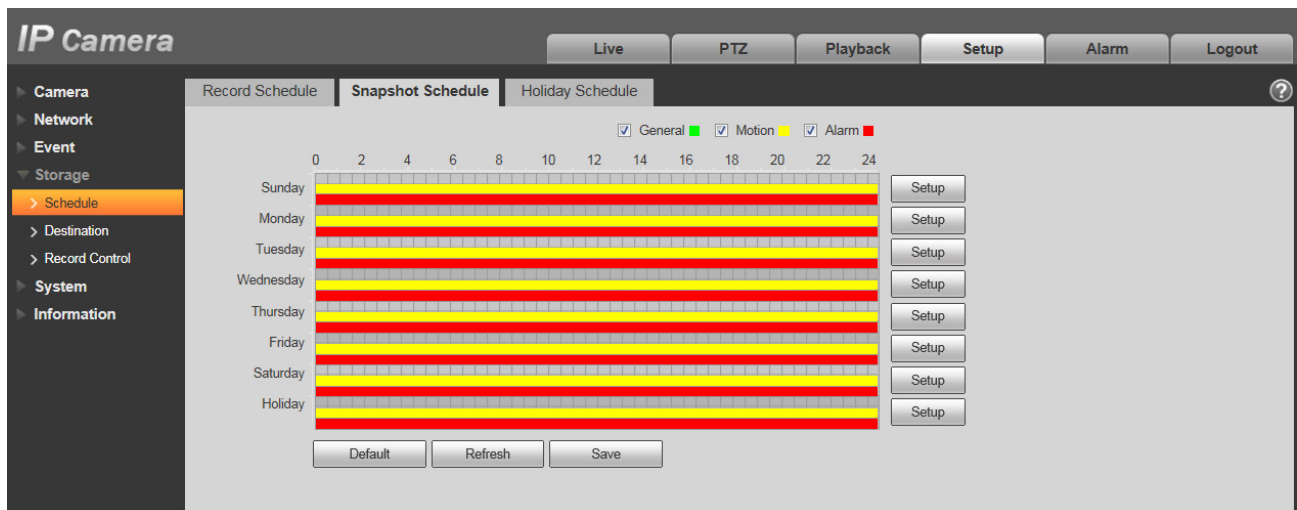

Figure 5-92

Step 2. From Monday to Sunday select snapshot time, click on setup on the right. See Figure 5-93.

- Set snapshot period according to actual need. There are six periods available each day.

- By checking or unchecking, user can add or delete three types of snapshot schedule: General, Motion and Alarm.

Note: Period setup can be done by dragging in snapshot schedule interface while not releasing left mouse.

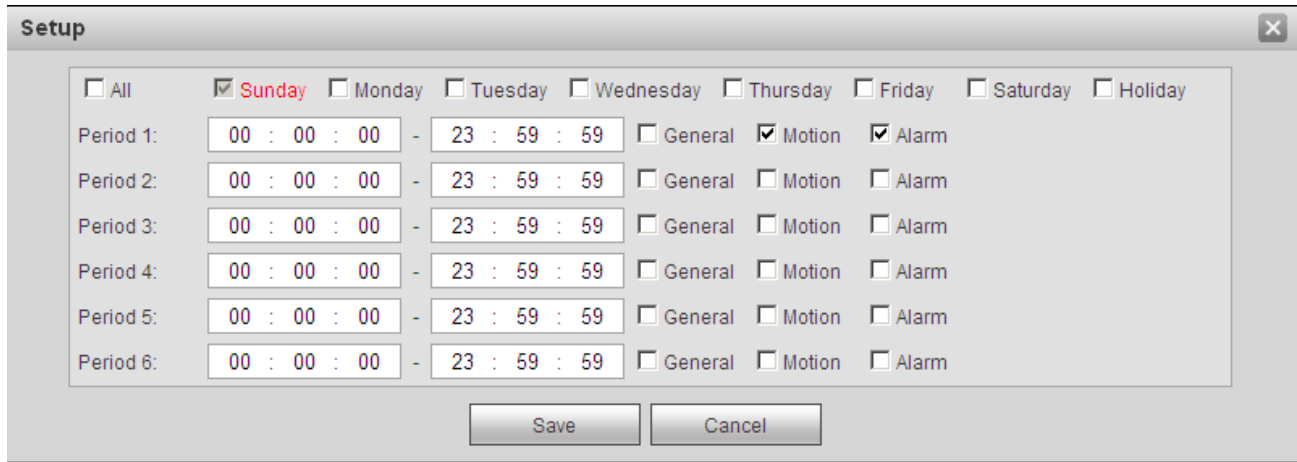

Figure 5-93

Step 3. Click on OK, return to snapshot schedule interface. See Figure 5-94.

- Green color stands for the general record/snapshot.
- Yellow color stands for the motion detect record/snapshot.
- Red color stands for the alarm record/snapshot.

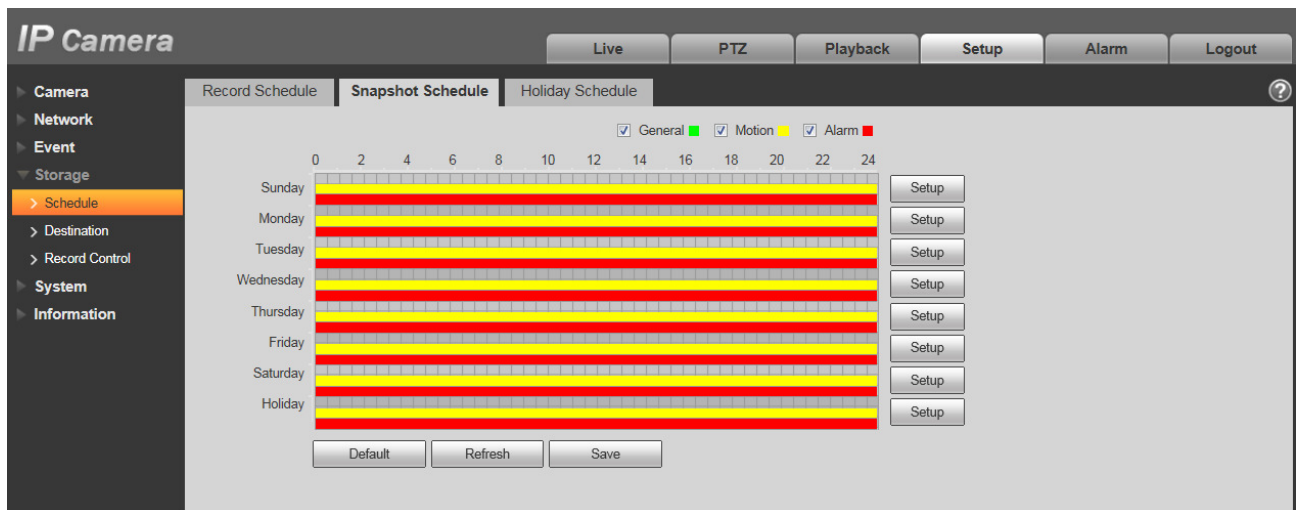

Figure 5-94

Step 5. In snapshot interface, click on OK. System prompts it is successfully saved.

5.4.1.3 Holiday Schedule

Holiday schedule can set specific date as holiday.

Step 1. Click on Holiday Schedule tab, see Figure 5-95.

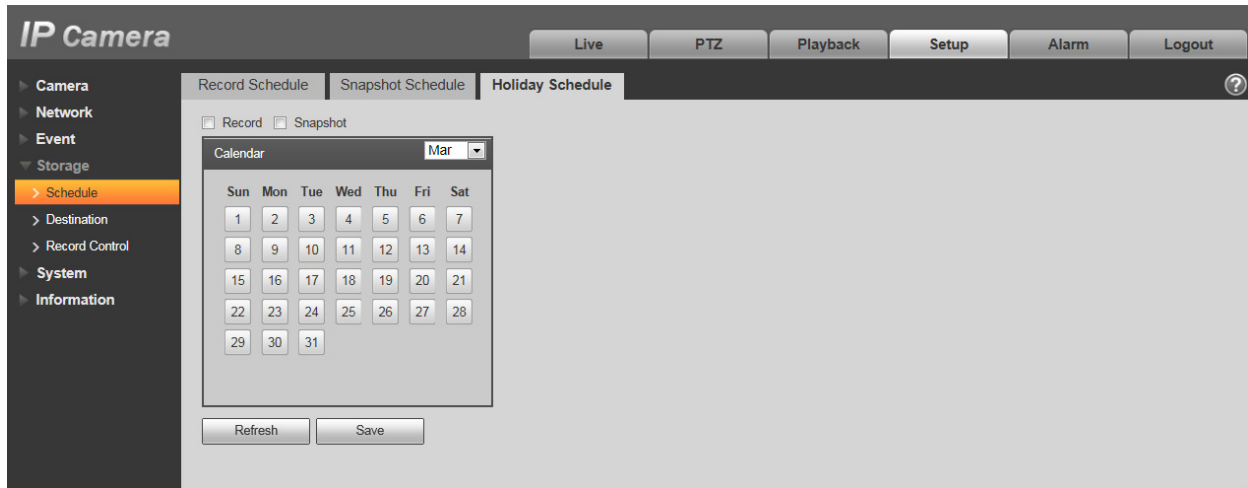

Figure 5-95

Step 2. Select date to set as holiday. The selected date will be highlighted in yellow.

Step 3. Check Record/Snapshot, click on Save. System prompts it is successfully saved.

Step 4. Check Record Schedule/Snapshot Schedule interface, click on setup next to Holiday, and refer to setup of Monday to Sunday.

Step 5. Complete setup of holiday, then it records/snapshots according to date in holiday schedule.

5.4.2 Destination

5.4.2.1 Path

The destination interface is shown as in Figure 5-96.

Path can config record and snapshot storage path. There are three options: Local, FTP and NAS. You can only select one mode. System can save according to the event types. It is corresponding to the three modes (general/motion/alarm) in the Schedule interface. Please check the box to enable the save functions.

Note: Only device supports SD card has local.

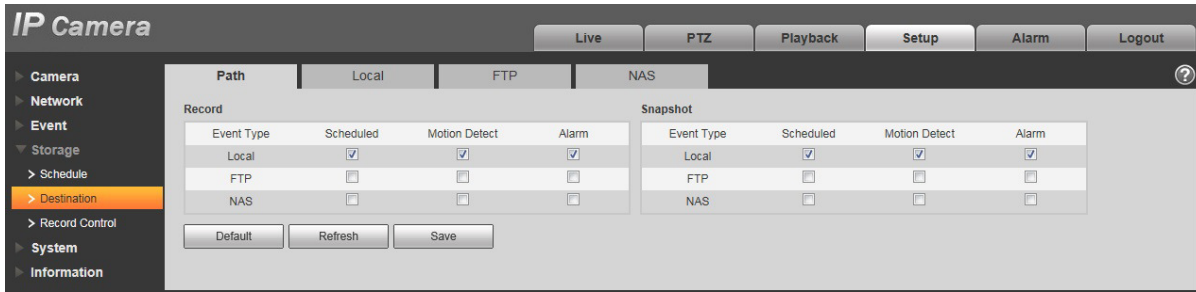

Figure 5-96

Please refer to the following sheet for detailed information.

Parameter	Function
Event Type	It includes: scheduled, motion detect and alarm.
Local	It saved in the SD card.
FTP	It saved in the FTP server.
NAS	It saved in NAS disk.

5.4.2.2 Local

The local interface is shown as in Figure 5-97.

Here you can view local Micro SD card or NAS disk information. You can also operate the read-only, write-only, hot swap and format operation.

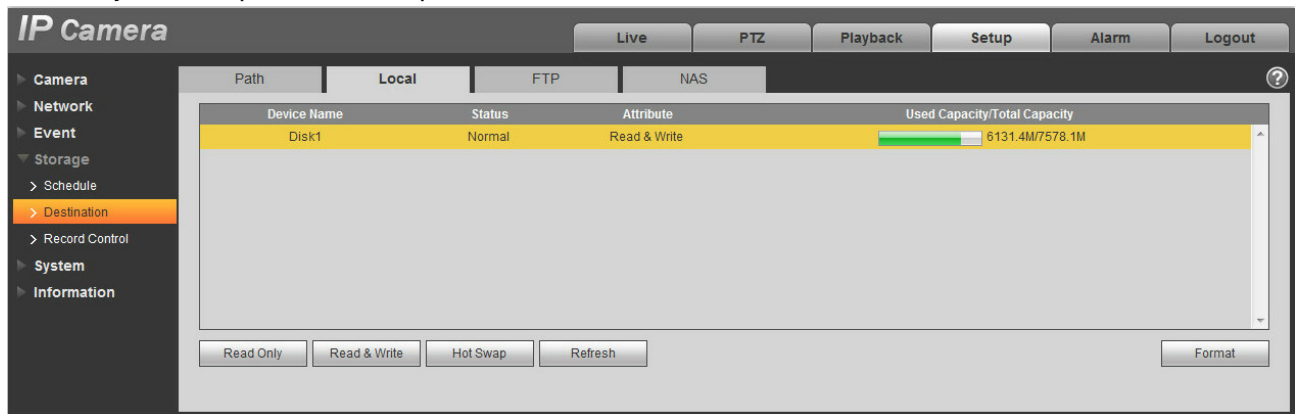

Figure 5-97

5.4.2.3 FTP

The FTP interface is shown as in Figure 5-96.

You need to check the box to enable the FTP function. When network disconnect occurred or there is malfunction. Emergency storage can save the record/snapshot picture to the local SD card. Click the test button to check if the FTP server can be connected for test.

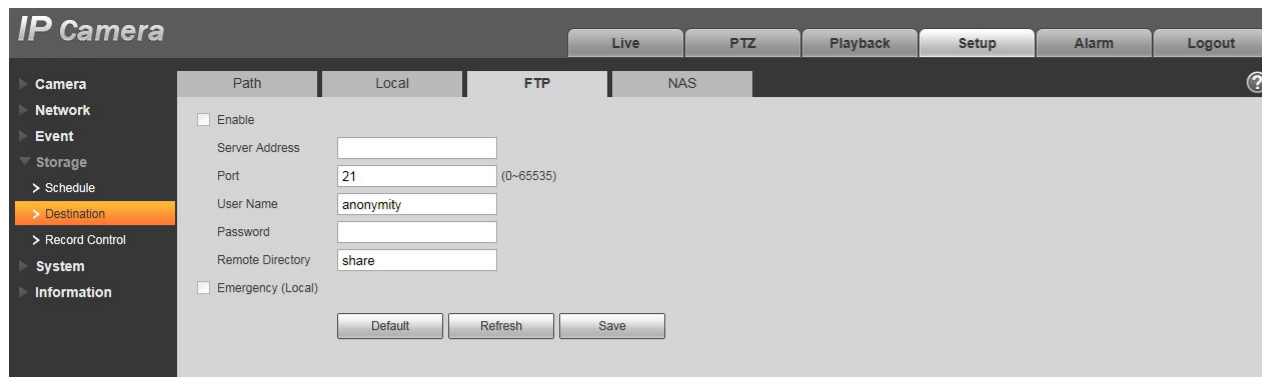

Figure 5-98

5.4.2.4 NAS

You need to check the box to enable the NAS function. Select NAS storage, fill in NAS server address and corresponding store path, then you can store video file or pictorial information in the NAS server. See Figure 5-99.

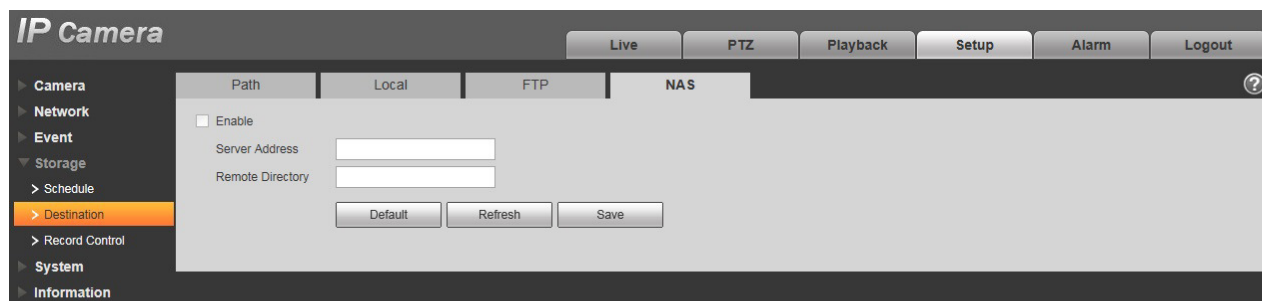

Figure 5-99

Parameter	Function
Server Address	Set IP address of NAS server.
Remote Directory	Set storage directory, videos and pictures can be stored in to corresponding server directory.

5.4.3 Record control

The record control interface is shown as in Figure 5-100.

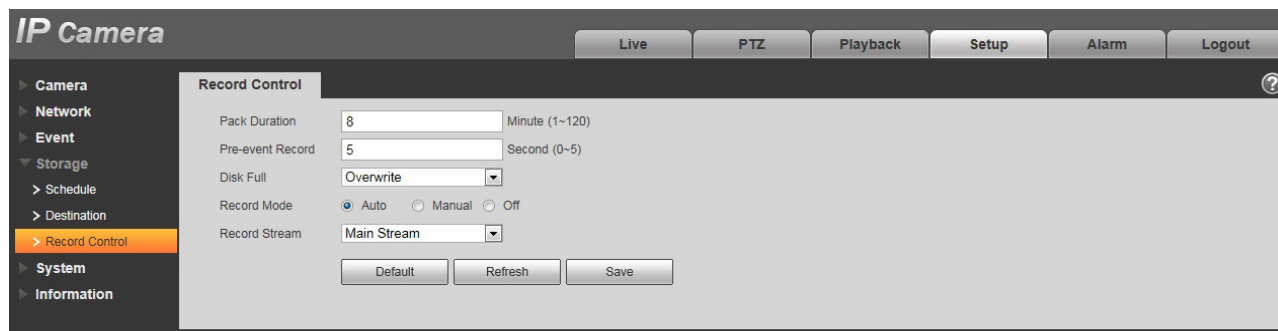

Figure 5-100

Please refer to the following sheet for detailed information.

Parameter	Function
Pack Duration	Here you can select file size within 1 min~120min. Default setup is 8 minutes.
Pre-record	Please input pre-record value here. For example, system can record the four seconds video in the buffer. The record begins from the fifth second. Note: Configure pre-record time, when alarm or motion detection occurs, if there is no record, system will record the preceding n seconds record.
Disk Full	There are two options: stop recording or overwrite the previous files when HDD is full. <ul style="list-style-type: none"> ● Stop: Current working HDD is overwriting or current HDD is full, it will stop record. ● Overwrite: Current working HDD is full; it will overwrite the previous file.
Record mode	There are three modes: Auto/manual/close.
Record stream	There are two options: main stream and sub stream.

5.5 System

5.5.1 General

The General interface is shown as in Figure 5-101.

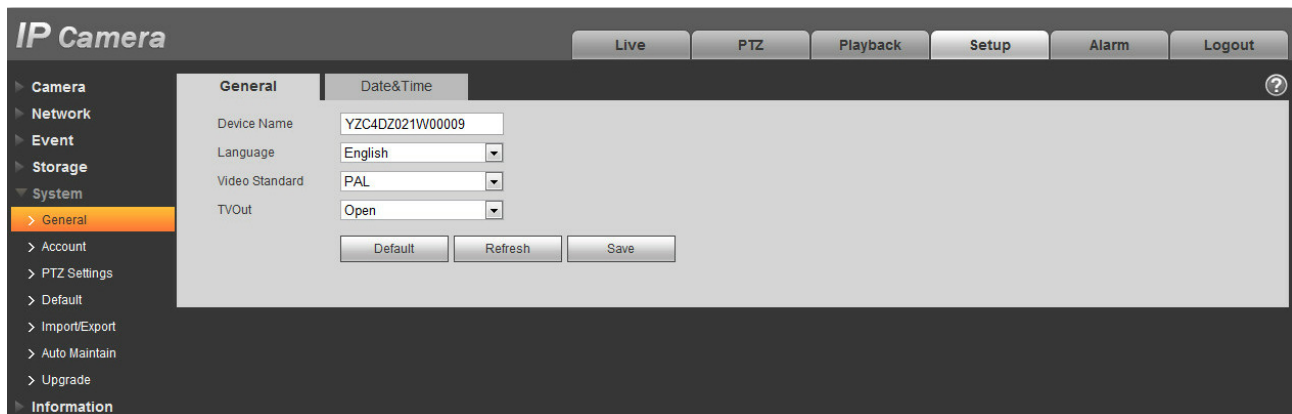

Figure 5-101

Please refer to the following sheet for detailed information.

Parameter	Function
Device Name	It is to set device name. Note: Different devices have different names.
Video Standard	This is to display video standard such as PAL.
Language	You can select the language from the dropdown list.
TV Out	You can open or close the function, it can only be supported by the devices with TV Out. <ul style="list-style-type: none"> ● Intelligent function will be disabled when TV Out is opened. ● It will auto close TV Out when intelligent function is enabled. ● Some devices support SDI and HDCVI.

The date and time interface is shown as in Figure 5-102.

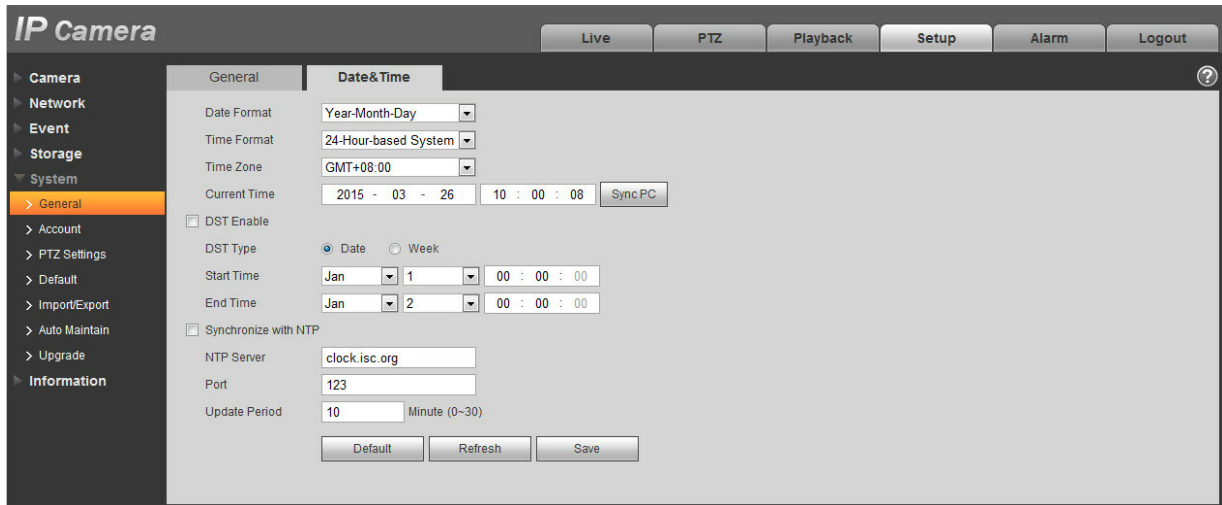

Figure 5-102

Please refer to the following sheet for detailed information.

Parameter	Function
Date format	Here you can select date format from the dropdown list.
Time Format	There are two options: 24-H and 12-H.
Time zone	The time zone of the device.
Current Time	It is to set system time. It becomes valid after you set.
Sync PC	You can click this button to save the system time as your PC current time.
DST Enable	Here you can set both begin and end time of daylight saving time. You can set according to the date format or the week format.
Synchronize with NTP	You can check the box to enable NTP function.
NTP server	You can set the time server address.
Port	It is to set the time server port.
Update period	It is to set the sync periods between the device and the time server.

5.5.2 Account

- For user name and user group, the max length is 31 characters, which can be made up of digit, letter, underline, hyphen, dot and @.
- Password can be 0~32 characters in number and letter only. User can modify other user's password.
- User and group can be manually added to 18 and 8 respectively.
- User management adopts group/user modes. The user name and the group name shall be unique. One user shall be included in only one group.
- Currently logged in user cannot change his/her own right.

5.5.2.1 Username

In this interface you can enable anonymity login, add/remove user and modify user name. See Figure 5-103.

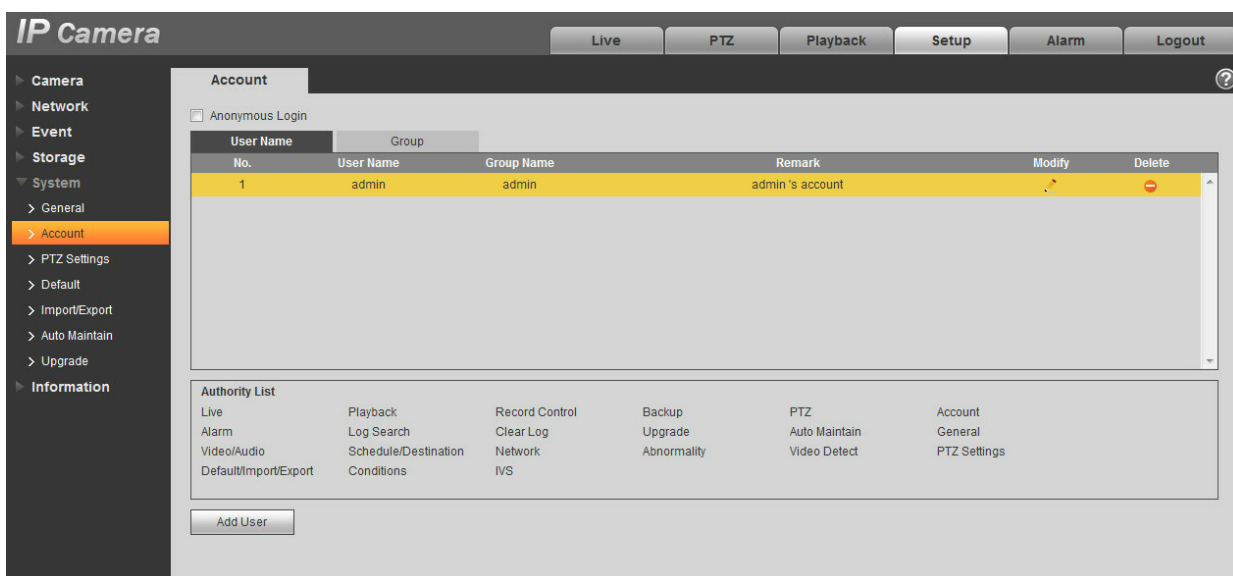

Figure 5-103

Enable anonymity login: Enable anonymity login, and input IP. No username or password is required, you can log in by anonymity (with limited rights). You can click logout to end your session.

Add user: It is to add a name to group and set the user rights. See Figure 5-104.

Hidden user "default" is for system interior use only and cannot be deleted. When there is no login user, hidden user "default" automatically login. You can set some rights such as monitor for this user so that you can view some channel view without login.

Here you can input the user name and password and then select one group for current user.

Please note the user rights shall not exceed the group right setup.

For convenient setup, please make sure the general user has the lower rights setup than the admin.

The image shows a software dialog box titled "Add User". It features a close button in the top right corner. The dialog contains the following fields and controls:

- User Name:** A text input field.
- Password:** A text input field.
- Confirm Password:** A text input field.
- Group:** A dropdown menu with "admin" selected.
- Remark:** A text input field.
- Authority List:** A section containing a checked checkbox for "All" and a scrollable list of permissions, each with a checked checkbox:
 - Live
 - Playback
 - Record control
 - Backup

At the bottom of the dialog are two buttons: "Save" and "Cancel".

Figure 5-104

Modify user

It is to modify the user property, belonging group, password and rights. See Figure 5-105.

Modify password

It is to modify the user password. You need to input the old password and then input the new password twice to confirm the new setup. Please click the OK button to save.

Please note, the password ranges from 0-digit to 32-digit. It shall include the number and letter only. For the user who has the account rights, he can modify the password of other users.

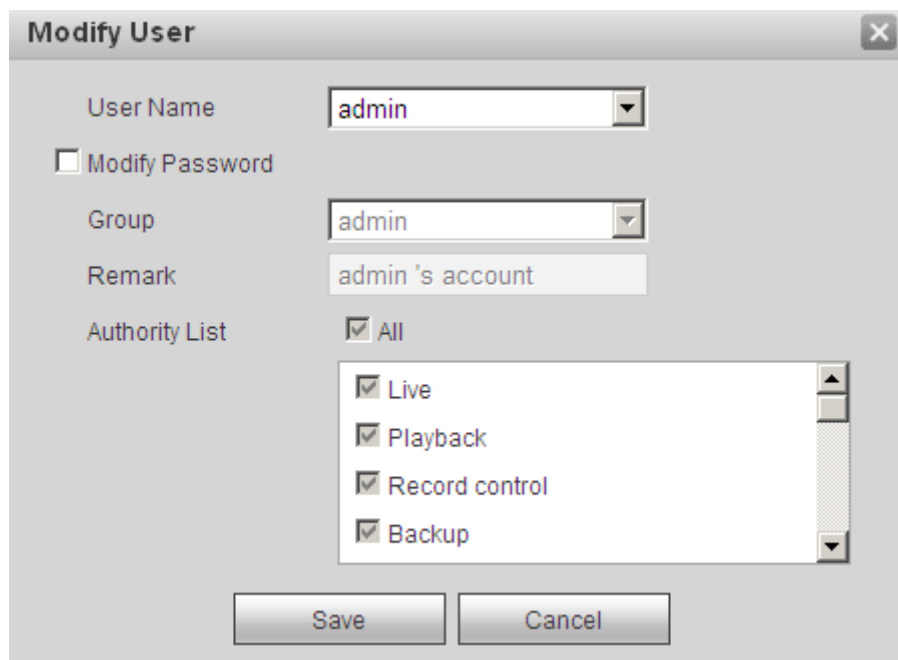

Figure 5-105

5.5.2.2 Group

The group management interface can add/remove group, modify group password and etc. The interface is shown as in Figure 5-106.

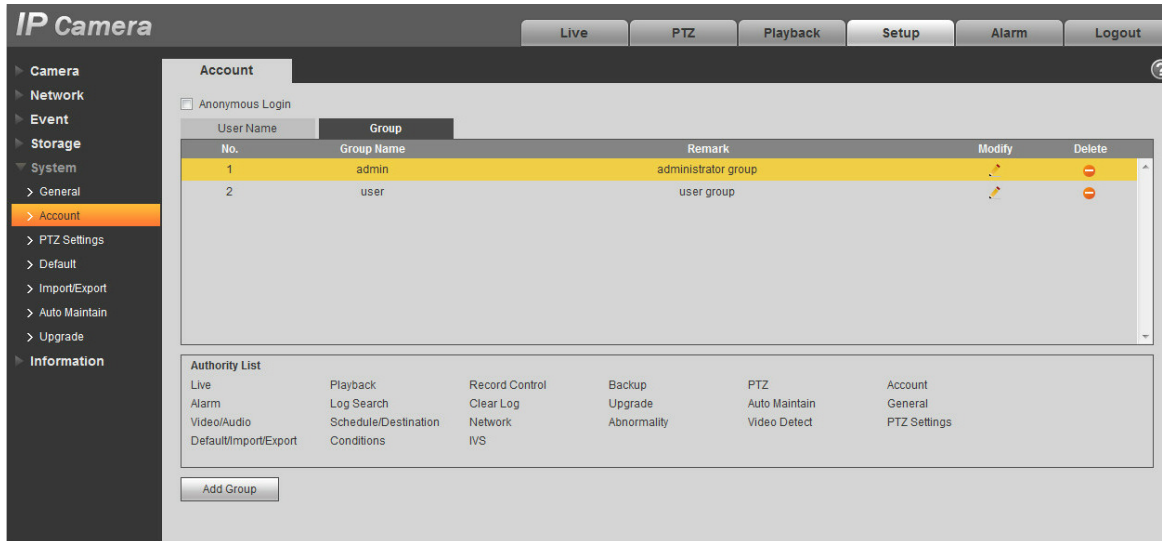

Figure 5-106

Add group: It is to add group and set its corresponding rights. See Figure 5-107.

Please input the group name and then check the box to select the corresponding rights. It includes: preview, playback, record control, PTZ control and etc.

The 'Add Group' dialog box features a title bar with a close button. It contains two text input fields: 'Group' and 'Remark'. Below these is a checkbox labeled 'All'. A scrollable list box contains four items, each with an unchecked checkbox: 'Live', 'Playback', 'Record control', and 'Backup'. At the bottom, there are two buttons: 'Save' and 'Cancel'.

Figure 5-107

Modify group

Click the modify group button, you can see an interface is shown as in Figure 5-108. Here you can modify group information such as remarks and rights.

The 'Modify Group' dialog box has a title bar with a close button. The 'Group' field is a dropdown menu currently showing 'admin'. The 'Remark' field is a text input containing 'administrator group'. Under 'Authority List', the 'All' checkbox is checked. A scrollable list box shows four items, each with a checked checkbox: 'Live', 'Playback', 'Record control', and 'Backup'. At the bottom, there are two buttons: 'Save' and 'Cancel'.

Figure 5-108

5.5.3 PTZ

Please note only some series products support this function.

The PTZ settings interface is shown as in Figure 5-91.

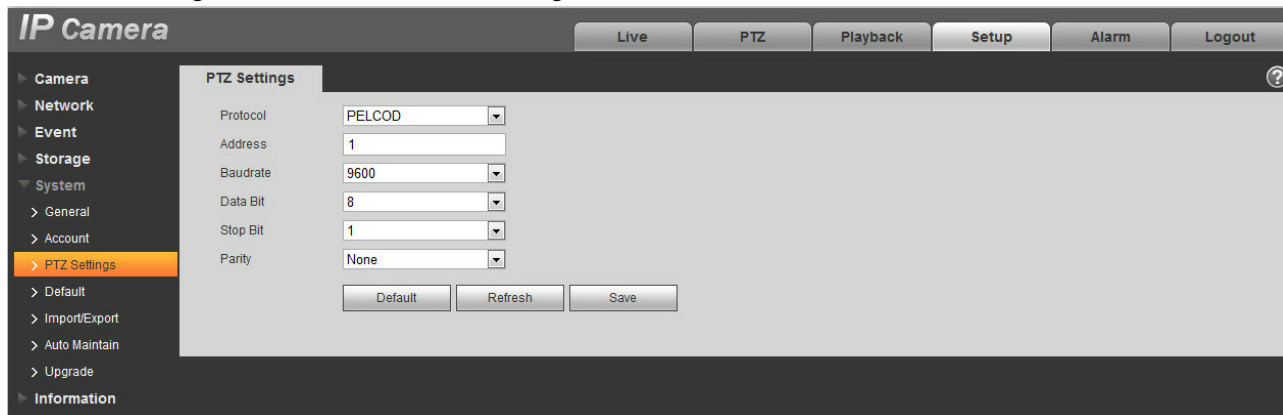

Figure 5-109

Please refer to the following sheet for detailed information.

Parameter	Function
Protocol	Select the corresponding dome protocol.
Address	Set corresponding dome address. Default value is 1. Please note your setup here shall comply with your dome address; otherwise you cannot control the speed dome.
Baud Rate	Select the dome baud rate. Default setup is 9600.
Data Bit	Default setup is 8.
Stop bit	Default setup is 1.
Parity	Default setup is none.

5.5.4 Default

The default setup interface is shown as in Figure 5-110.

Please note system cannot restore some information such as network IP address, account and so on.

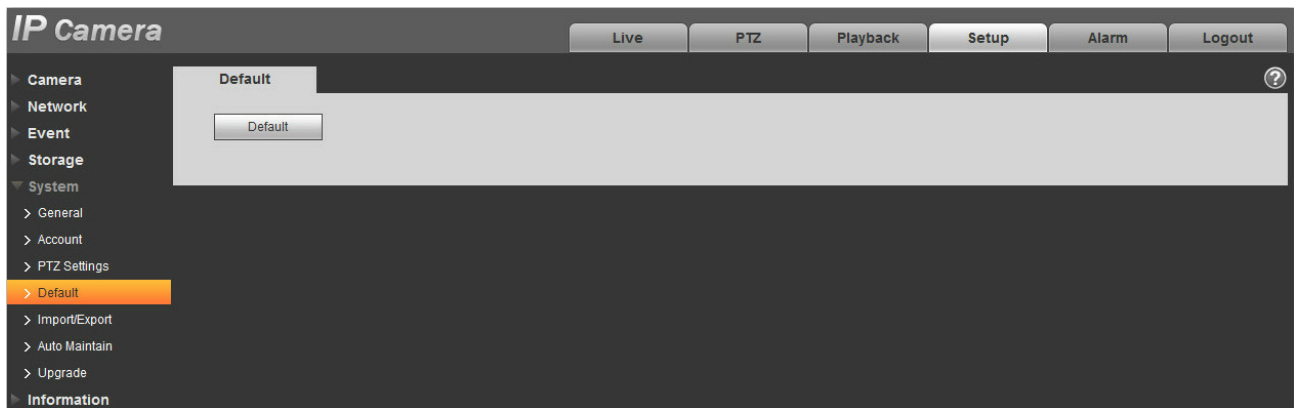

Figure 5-110

5.5.5 Import/Export

The interface is shown as in Figure 5-111.

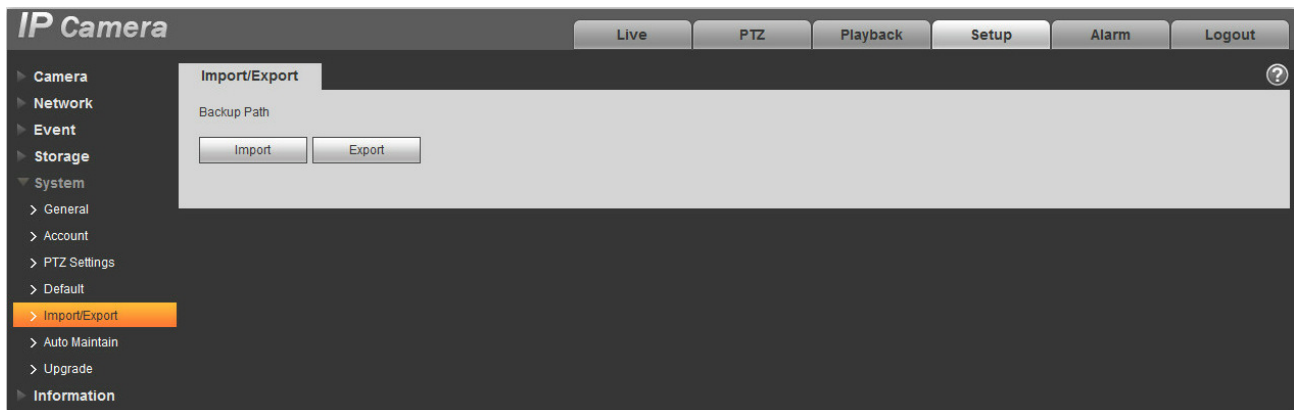

Figure 5-111

Please refer to the following sheet for detailed information.

Parameter	Function
Import	It is to import the local setup files to the system.
Export	It is to export the corresponding system setup to your local PC.

5.5.6 Remote control

Note:

It is supported by some devices.

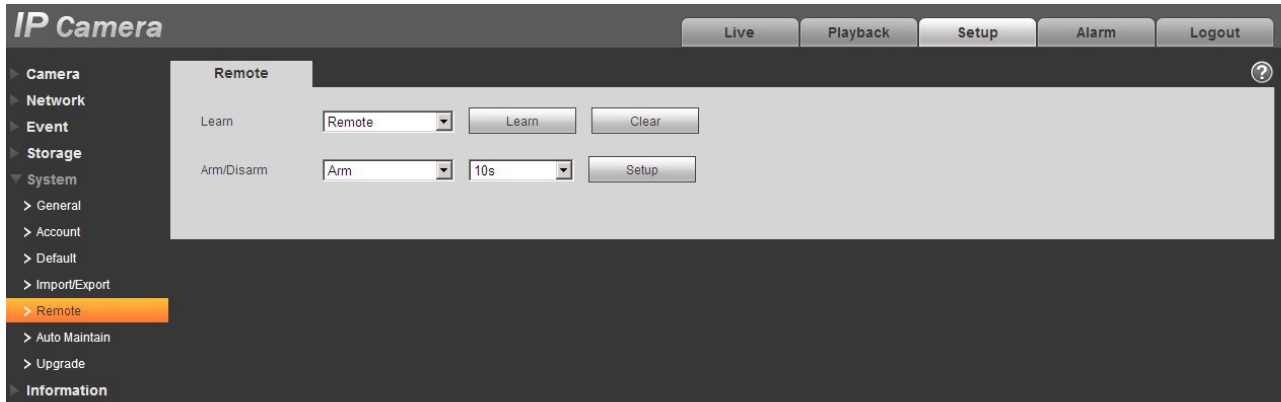

Figure 5-112

Parameter	Function
Learn	Bind remote control or wireless alarm with equipment.
Clear	Unbind remote control with equipment.
Arm/Disarm	Start arm after the time you choose, disarm comes into effect immediately. Note: With disarm status, all the following alarms won't trigger: motion detect alarm, masking alarm, local alarm, PIR alarm, wireless alarm.

5.5.6 Auto Maintenance

The auto maintenance interface is shown as in Figure 5-113.

Here you can select auto reboot and auto delete old files interval from the dropdown list.

If you want to use the auto delete old files function, you need to set the file period.

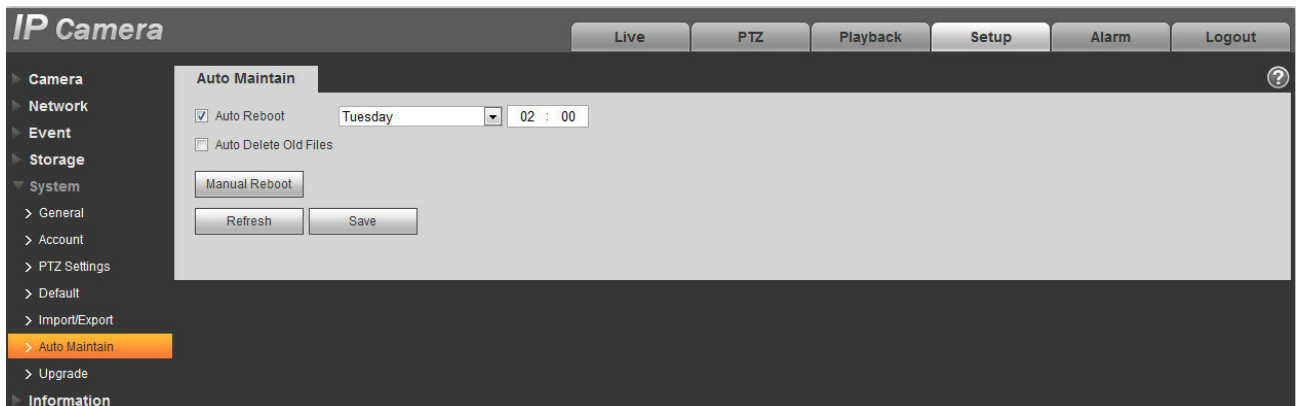

Figure 5-113

Parameter	Function
Auto Reboot	Check it and set auto reboot time.
Auto Delete Old Files	Check it and set period within 1~31 days.

5.5.7 Upgrade

The upgrade interface is shown as in Figure 5-114.

Please select the upgrade file (file extension is “.bin”) and then click the update button to begin firmware update.

Important

Improper upgrade program may result in device malfunction!

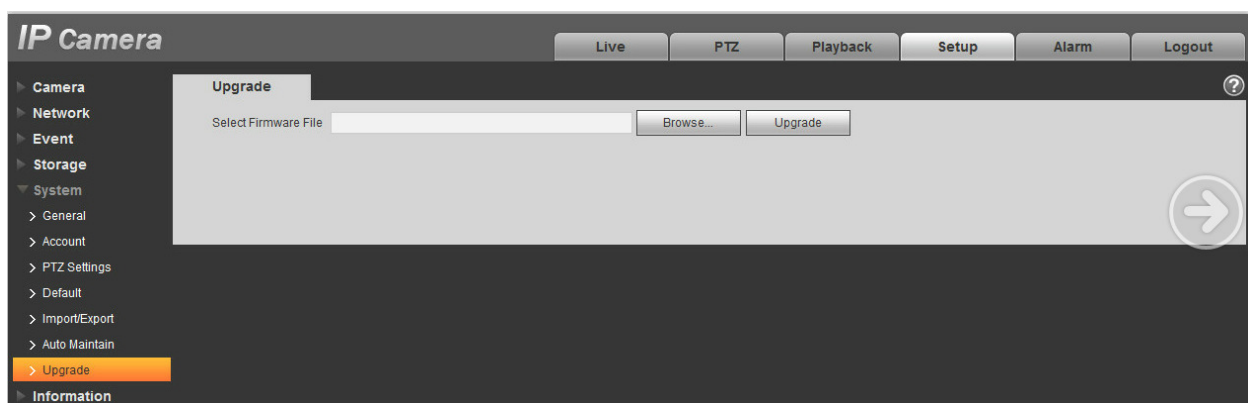

Figure 5-114

5.6 Information

5.6.1 Version

The version interface is shown as in Figure 5-115.

Here you can view system hardware features, software version, release date and etc. Please note the following information is for reference only.

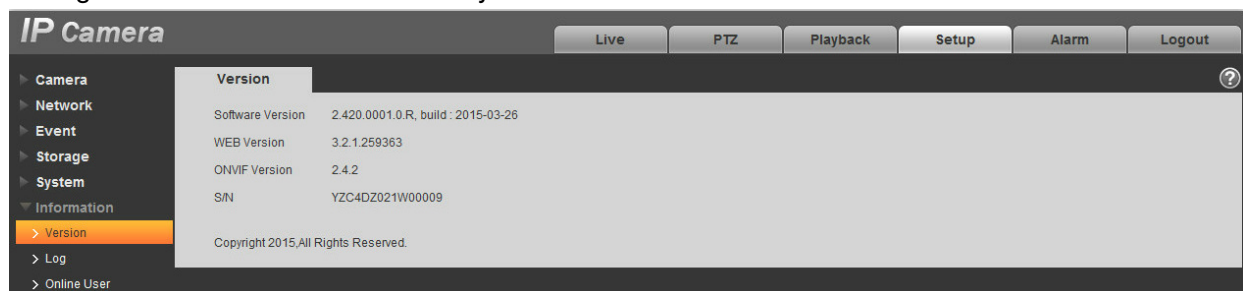

Figure 5-115

5.6.2 Log

Here you can view system log. See Figure 5-116.

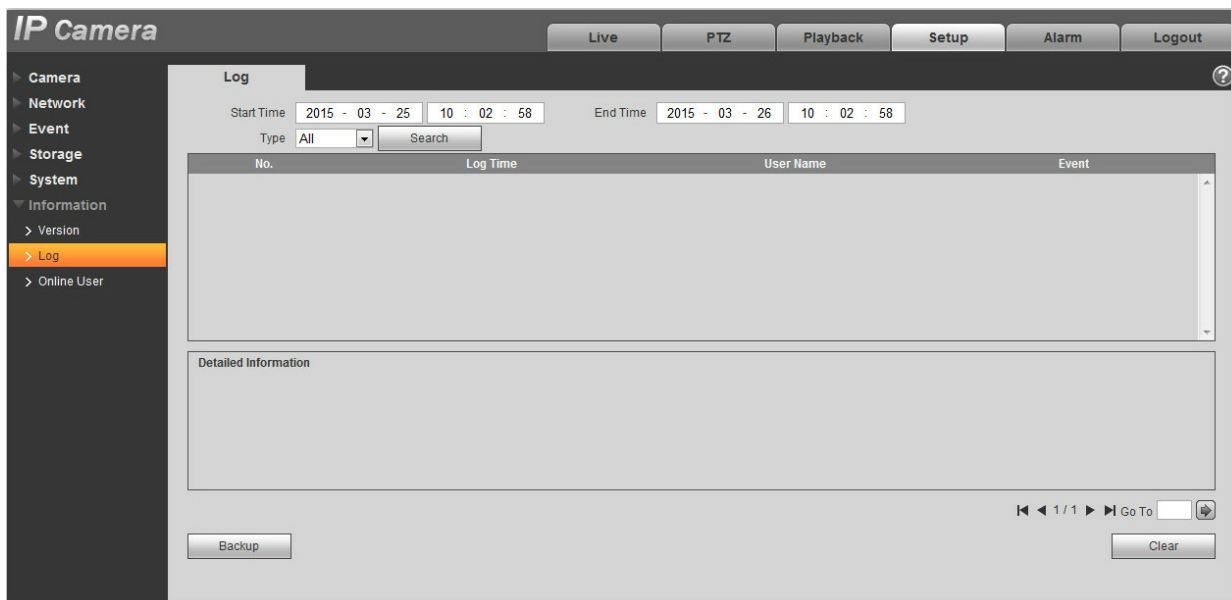

Figure 5-116

Please refer to the following sheet for log parameter information.

Parameter	Function
Start time	Set the start time of the requested log. (The earliest time is 2000/1/1)
End time	Set the end time of the requested log. (The latest time is 2037/12/31)
Type	Log type.
Search	You can select log type from the drop down list and then click search button to view the list. You can click the stop button to terminate current search operation.
Log information	You can select one item to view the detailed information.
Clear	You can click this button to delete all displayed log files. Please note system does not support clear by type.
Backup	You can click this button to backup log files to current PC.

5.6.3 Online User

The online user interface is shown as in Figure 5-117.

Here you can view current online user, group name, IP address and login time.

IP Camera

Live PTZ Playback Setup Alarm Logout

- Camera
- Network
- Event
- Storage
- System
- Information
 - Version
 - Log
 - Online User**

Online User ?

No.	Username	User Local Group	IP Address	User Login Time
1	admin	admin	10.34.9.220	2015-03-26 09:45:22
2	admin	admin	10.34.7.148	2015-03-26 09:55:14

Refresh

Figure 5-117

6 Alarm

Please note some series product does not support this function.

Click alarm function, you can see an interface is shown as in Figure 6-1.

Here you can set device alarm type and alarm sound setup.

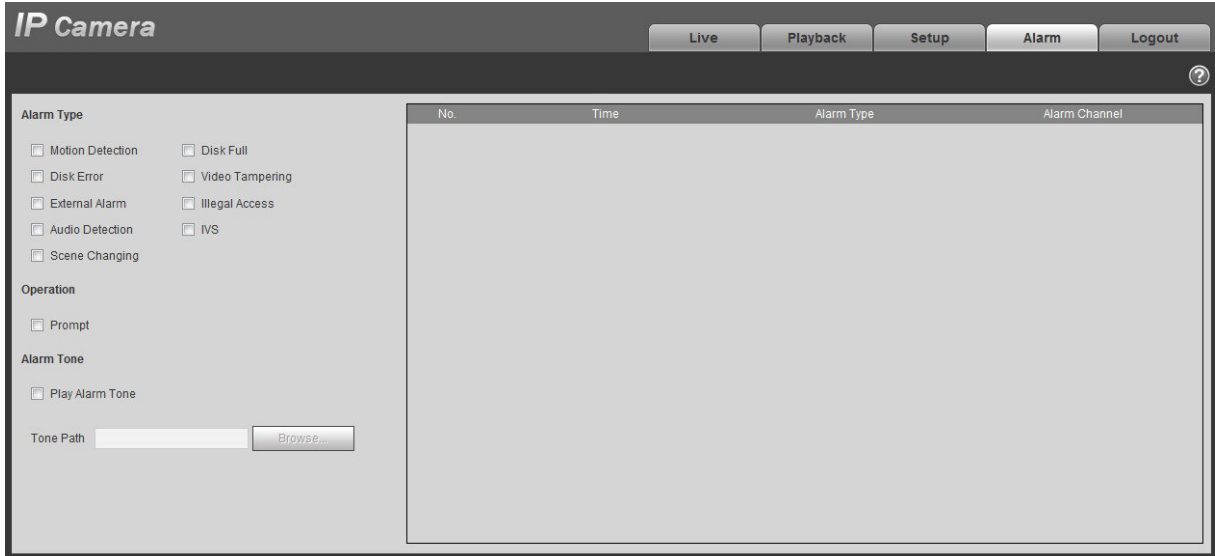



Figure 6-1

Please refer to the following sheet for detailed information.

Type	Parameter	Function
Alarm type	Motion detection	System alarms when motion detection alarm occurs,
	Disk full	System alarms when disk is full.
	Disk Error	System records alarm info when disk error happens.
	Video Tampering	System alarms when video is tampering.
	External alarm	Alarm input device sends out alarm.
	Illegal Access	System alarms when there is illegal access.
	Audio Detection	System alarms when there is audio detect.
	IVS	System alarms when IVS event is triggered.
	Scene Changing	System will record alarm info when triggering scene changing.

Type	Parameter	Function
Operation	Prompt	When alarm is triggered, there will be s  in main menu of alarm interface and system automatically records alarm info. The icon disappears when user click on alarm menu bar. Note: If alarm interface is displayed, when alarm is triggered, there will be no image prompt, but alarm record will be in list on the right.
Alarm Tone	Play Alarm Tone	Click it and select the path of audio file to be played in the tone path, when the subscribed alarm event triggers, it will play the selected audio file to prompt that there is alarm event which has been triggered.
	Tone Path	You can customize the storage path of the alarm tone.

7 Log out

Click log out button, system goes back to log in interface. See Figure 7-1.



Figure 7-1

Note:

- This manual is for reference only. Slight difference may be found in user interface.
- All the designs and software here are subject to change without prior written notice.
- All trademarks and registered trademarks mentioned are the properties of their respective owners.
- If there is any uncertainty or controversy, please refer to the final explanation of us.
- Please visit our website for more information.

www.dantesecurity.net

sales@dantesecurity.net

support@dantesecurity.net